

GSP9700 Series Road Force Measurement System

With SmartWeight™ Balancing Technology

Software Version 5.0



HUNTER
Engineering Company

OWNER INFORMATION

Model Number _____
 Software Version Number _____
 Serial Number _____
 Date Installed _____
 Service and Parts Representative _____
 Phone Number _____
 Sales Representative _____
 Phone Number _____

Concept and Procedure Training Checklist

	<u>Trained</u>	<u>Declined</u>
<u>Safety Precautions</u>	<input type="checkbox"/>	<input type="checkbox"/>
Quick-Thread		
Autostart		
Servo-Stop		
<u>Maintenance & Calibration</u>	<input type="checkbox"/>	<input type="checkbox"/>
Cleaning, Lubrication, and Maintenance of Adaptors, Hub, and Shaft		
Calibrating the Balancer		
Calibrating the Load Roller and Dataset Arms		
Calibrating the Inflation Station		
<u>Mounting the Wheel/Tire Assembly</u>	<input type="checkbox"/>	<input type="checkbox"/>
Verifying Mounting Repeatability with Centering Check® Feature		
Cone Mounting		
Pressure Ring and Spacers		
Flange Plate and Cone Mounting		
<u>Wheel Balancing</u>	<input type="checkbox"/>	<input type="checkbox"/>
SmartWeight™		
Standard		
Mixed Weights		
Adhesive Weights with Auto Dataset Arms		
Split-Spoke		
Patch Balancing with Auto Dataset Arms (optional)		
<u>Do's and Don'ts of Wheel Balancing</u>	<input type="checkbox"/>	<input type="checkbox"/>
<u>Road Force™ Measurement and ForceMatching™</u>	<input type="checkbox"/>	<input type="checkbox"/>
<u>Adjusting P/SUV/LT Limits</u>	<input type="checkbox"/>	<input type="checkbox"/>
Assembly Measurements		
Applying Previous Wheel Measurements		
Applying Previous Tire Measurements		
Wheel Measurement with Dataset Arms		
Tire Installed		
Bare Rim		
<u>Road Force™ Measurement First Harmonic Diagnosis Screen</u>	<input type="checkbox"/>	<input type="checkbox"/>
"Current Runout and Force Variation"		
<u>"Diagnosis Explanation" and "Details" Screens</u>	<input type="checkbox"/>	<input type="checkbox"/>
Match Codes		
MatchMaker Procedure Explained		
<u>Do's and Don'ts of Road Force™ Measurement</u>	<input type="checkbox"/>	<input type="checkbox"/>

Individuals and Date Trained

CONTENTS

1. GETTING STARTED	1
1.1 Introduction	1
1.2 For Your Safety	1
Hazard Definitions.....	1
IMPORTANT SAFETY INSTRUCTIONS	2
Electrical.....	3
Decal Information and Placement.....	4
Right Side View	4
Left Side View.....	5
Back View.....	6
Specific Precautions/Power Source.....	7
Turning Power ON/OFF	7
Equipment Installation and Service	8
Equipment Specifications.....	8
Electrical	8
Air	8
Atmospherics.....	8
Sound Pressure Level.....	8
Safety Summary	8
Explanation of Symbols.....	8
1.3 Equipment Components	9
Standard Balancer Accessories.....	10
1.4 Operating the Console	11
Using Softkeys	11
Primary Balancing Display	12
Using the Control Knob (GSP9712).....	12
Using Control Knobs (GSP9702).....	13
Resetting the Program	13
Using the Screen Saver/Merchandising Display.....	13
2. BALANCING OVERVIEW	15
2.1 Balancing Modes	15
SmartWeight™ Balancing Technology	15
Balancing Theory	15
Static Imbalance.....	15
Couple Imbalance.....	16
Static and Dynamic Imbalance Sensitivity.....	17
2.2 Identifying the Static Balance Weight Plane	18
2.3 Identifying the Dynamic Balance Weight Planes	19
2.4 SmartWeight™ Dynamic Weight Planes	20
3. MOUNTING WHEELS ON THE BALANCER	21
3.1 Mounting the Wheel Using Wheel Lift (Optional)	21
Raising the Tire/Wheel Assembly.....	21
Lowering the Tire/Wheel Assembly	23
3.2 Mounting the Wheel (Without Wheel Lift)	23
Mounting Error Detection Features.....	24
Front/Back Cone Mounting	24
Using Plastic Wheel Mounting Washer.....	26
Cone/Flange Plate Mounting	27
Expandable Collet Mounting.....	28
Using the Pressure Ring and Spacers.....	28
Pressure Ring.....	28
Spacers	29
CenteringCheck®.....	30
3.3 On-Vehicle Wheel Mounting Methods	33
Hub Centric.....	33
Lug Centric.....	33

4. BALANCING A WHEEL.....	35
4.1 Balancing Procedures	35
SmartWeight™ Balancing Technology	35
Using SmartWeight™	35
Switching from SmartWeight™ to Traditional Dynamic Balancing Modes....	37
Dynamic Balancing Selection	37
Static Balancing Selection	37
Static Balance Mode Reminder for “Dynamic Balance Importance” (Except Patch Balance)	38
Selecting Weight Types and Placement Modes	39
STANDARD Balancing Procedure (Using Clip-On Weights)	39
MIXED WEIGHTS Balancing Procedure (Combination of Clip-On & Adhesive Weights).....	41
ADHESIVE WEIGHTS Balancing Procedure (Adhesive Weights Only)	43
PATCH BALANCE® Procedure	45
4.2 Using the Auto Dataset® Arms	48
Automatic Weight Position Measurement.....	48
Manual Weight Position Measurement	48
Measuring Dimensions for Standard Clip-on Weight Balancing.....	49
Measuring Dimensions for Mixed Weights (Clip-on/Tape-on) Balance	49
Measuring Dimensions for Adhesive Weights Balancing (Tape-on/Tape-on)....	50
Measuring 20 Inch or Larger Rims.....	51
Adjustable Length Inner Dataset® Arm	51
Servo-Aided Adhesive Weight Placement.....	51
Manual Adhesive Weight Placement.....	53
Rim Runout Measurements	54
Single Arm Rim Runout External Measurement (Tire and Wheel Assembly).....	54
Dual Arm Rim Runout External Measurement (Tire and Wheel Assembly) .	54
Rim Runout Measurement (Bare Rim)	56
4.3 Primary and Popup Screens	57
Primary Screen Selection	57
Balance Primary Screen	58
4.4 Load Roller	60
Load Roller Operation.....	60
4.5 ForceMatching™	61
ForceMatching™ Procedures	62
ForceMatching™ Using Previous Bare Rim Measurement	63
ForceMatching™ Using Previous Road Force™ Measurement.....	63
Using ForceMatch Codes Feature	64
Dial Indicator Gauges Feature	64
Lateral/Radial Rim High Spot Indicators Feature	65
Details/Diagnosis Explanation Key	65
Encountering ForceMatching™ Prediction Errors	65
Do’s and Don’ts of Road Force™ Measurement.....	66
4.6 QuickMatch™ Tire and Wheel Mounting	66
QuickMatch™ Procedures	67
QuickMatch™ Using Previous Bare Rim Measurement.....	68
QuickMatch™ Using Previous Loaded Runout Measurement	68
Dial Indicator Gauges Feature	68
Lateral/Radial Rim High Spot Indicators Feature	69
Encountering ForceMatching™ or QuickMatching™ Prediction Errors.....	69
Do’s and Don’ts of Loaded Runout Measurement.....	70
4.7 StraightTrak® LFM (Lateral Force Measurement)	70
Disabling StraightTrak®	73
Vehicle Plan View	74
Net Tire Pull Arrow	74
Road Force™ Arrows	74
Changing Tag Numbers.....	75
Show Least Pull	76
Show Least Vibration	76
Show Alternate Placements.....	76

Show Details	77
Determining Tire Conicity Outliers.....	77
Printout.....	77
Inflation Pressure	78
4.8 Quick-Thread™ Feature	78
4.9 Motor Drive/Servo-Stop.....	79
4.10 Spindle-Lok® Feature.....	79
4.11 Hood Autostart Feature.....	79
4.12 Loose Hub Detect Feature	79
4.13 Blinding and Rounding	80
4.14 Inflation Station.....	81
5. BALANCING FEATURES AND OPTIONS	83
5.1 SmartWeight™ Balancing Technology.....	83
5.2 WeightSaver™ Wheel Balancing Feature.....	84
5.3 Quick-Thread™ Feature	84
5.4 Motor Drive/Servo-Stop.....	85
5.5 Spindle-Lok® Feature.....	85
5.6 Hood Autostart Feature.....	86
5.7 Loose Hub Detect Feature	86
5.8 Inflation Station.....	86
5.9 Split Weight® Feature	87
Split Weight® Operation	87
Correcting Large Imbalances.....	88
5.10 Split Spoke® Feature.....	88
Hiding Adhesive Weight behind Spoke.....	88
Re-entering Similar Wheel after Split Spoke® is Enabled.....	90
Placing Hidden Weight Inside of Hollow Spokes	91
5.11 MatchMaker™ Tire and Wheel Mounting Procedure.....	93
Tires Mounted on Rims.....	93
Tires Not Mounted to Rims	94
5.12 Diagnosis Explanation Screen (Limits Disabled)	95
5.13 Diagnosis Explanation Screen (Limits Enabled)	95
5.14 Details Screen	96
5.15 Print Summary	97
5.16 Harmonics & T.I.R. Data/Plots	98
Assembly Data Plots Screen	98
Tire Data Plots Screen.....	99
5.17 Statistics	100
Show Statistics.....	100
Weight Savings	101
Rim Data Plots Screen.....	102
6. EQUIPMENT INFORMATION	103
6.1 Software Identification	103
6.2 Program Cartridge Removal and Installation.....	103
6.3 Balancer Set Up	104
Setting Up the Display Language	105
Setting Up the Printout Language.....	105
Setting Up the QuickMatch® Feature	105
Setting Up the Use Limits Feature.....	106
Setting Up the Screen Saver Time-out.....	106
Setting Up the Hood Autostart Feature.....	107
Setting Up the Servo-Stop/Servo-Push	107
Setting Up the Quick-Thread™ Feature	108
Setting Up the Balance Check Spin.....	108
Setting Up the Weight Units.....	108
Setting Up the Inflation Station Units	109
Setting Up the Runout Units	109
Setting Up the Road Force Units	109
Setting Up the Prompted Inflation Station.....	110
Setting Up the Prompted Centering Checks.....	110

6.4 Service Mode Setup and Features	111
Setting Up the Runout & Road Force™ Limits	111
Setting the “P” Limits	111
Setting the “P/SUV” Limits.....	111
Setting the “LT” Limits	112
Setting the Limits to “Factory Default”	112
Programmed Road Force™ Limits.....	112
Setting Up the Balance Limits.....	113
Main Selections	113
Setting Up the Weight Units	113
Setting Up the Ounce Round Amount.....	113
Setting Up the Gram Round Amount.....	113
Setting the Limits Displayed	113
Non-SmartWeight Options	113
Setting Up the Ounce Blind Amount.....	113
Setting Up the Gram Blind Amount	113
SmartWeight™ Options - Setting Up the Force Limits.....	114
WeightSaver™ Residual Goal.....	114
Setting Up the Inner Dataset Arm Type.....	114
Setting Up the Console Type.....	115
Setting Up the Load Roller Type.....	115
7. CALIBRATION AND MAINTENANCE	116
7.1 Calibration Procedures	116
Balancer (3 Spin Procedure).....	117
Inner Dataset® Arm (Calibration Tool, 221-672-1, Required)	118
Outer Dataset® Arm (Calibration Tool, 221-672-1, Required)	121
Load Roller (Calibration Tool, 221-672-1, Required).....	123
Servo-Stop	125
Quick Calibration Check Procedure.....	126
7.2 Diagnostic Procedures	126
Force Sensors.....	127
Rotary Encoders	127
Keys and Switches.....	127
Data Acquisition Circuits	127
Dataset® Arm Sensors	127
Loaded Runout Sensor	127
7.3 Printing	127
Changing Ribbon Cartridge (P/N 162-42-2):	128
Bottom Feed Paper Loading	128
7.4 Cleaning the Console	128
7.5 Spindle Hub Face and Shaft Maintenance	129
7.6 Mounting Cone Maintenance	129
8. THEORY OF OPERATION	131
8.1 Harmonic Vibrations	131
8.2 Road Force™ Measurement	133
Force Variation.....	133
Tire Radial Force Variation (Uniformity).....	134
8.3 Radial Force Variation (RFV)	134
8.4 Radial Force Variation vs. Unloaded Run Out	135
8.5 Road Force™ Vibration Placed into Perspective	135
8.6 StraightTrak® Lateral Force Measurement System	136
StraightTrak® Lateral Force Measurement	136
Tire Pull Measurement and Correction.....	136
Theory	137
Conicity	138
Plysteer.....	138
Net Tire Pull.....	138
9. GLOSSARY	139
9.1 Balancing Terms	139

1. Getting Started

1.1 Introduction

The GSP9700 Series Road Force Measurement System is a wheel balancer with the added capabilities of measuring tire/wheel Road Force, Lateral Force, Assembly, and Wheel runout.

The GSP9700 simulates a “road test”, with a unique “load roller” which applies up to 1400 pounds of force against the rotating assembly. The roller measures the loaded runout of the assembly (deflection while under load) and automatically recommends corrections when needed. The GSP9700 technology eliminates many of the time consuming, subjective, and often non-productive manual measurements previously used to diagnose and repair ride disturbance concerns. The operation of this diagnostic tool is discussed later in this manual.

This manual provides operation instructions and information required to operate the GSP9700. Read and become familiar with the contents of this manual prior to operating the GSP9700.

The owner of the GSP9700 is solely responsible for arranging technical training. The GSP9700 is to be operated only by a qualified trained technician. Maintaining records of personnel trained is solely the responsibility of the owner and management.

“References”

This manual assumes that you are already familiar with the basics of tire balancing. The first section provides the basic information needed to operate the GSP9700. The following sections contain detailed information about equipment operation and procedures. “*Italics*” are used to refer to specific parts of this manual that provide additional information or explanation. For example, *Refer to “Equipment Components,” page 9.* These references should be read for additional information to the instructions being presented.

1.2 For Your Safety

Hazard Definitions

Watch for these symbols:

 CAUTION: Hazards or unsafe practices, which could result in minor personal injury or product or property damage.

 WARNING: Hazards or unsafe practices, which could result in severe personal injury or death.

 DANGER: Immediate hazards, which will result in severe personal injury or death.

These symbols identify situations that could be detrimental to your safety and/or cause equipment damage.

IMPORTANT SAFETY INSTRUCTIONS

When using your garage equipment, basic safety precautions should always be followed, including the following:

Read all instructions before operating the GSP9700.

Read and follow the instructions and warnings provided in the service, operation and specification documents of the products with which this GSP9700 is used (i.e., automobile manufacturers, tire manufacturers etc.).

Do not operate equipment with a damaged cord or equipment that has been dropped or damaged until a Hunter Service Representative has examined it.

Always unplug equipment from electrical outlet when not in use. Never use the cord to pull the plug from the outlet. Grasp plug and pull to disconnect.

If an extension cord is necessary, a cord with a current rating equal to or more than that of the equipment should be used. Cords rated for less current than the equipment may overheat. Care should be taken to arrange the cord so that it will not be tripped over or pulled.

Verify that the electrical supply circuit and the receptacle are properly grounded.

To reduce the risk of electrical shock, do not use on wet surfaces or expose to rain.

Verify the appropriate electrical supply circuit is the same voltage and amperage ratings as marked on the balancer before operating.

 **WARNING: DO NOT ALTER THE ELECTRICAL PLUG. Plugging the electrical plug into an unsuitable supply circuit will damage the equipment and may result in personal injury.**

To reduce the risk of fire, do not operate equipment near open containers of flammable liquids (gasoline).

Read and follow all caution and warning labels affixed to your equipment and tools. Misuse of this equipment can cause personal injury and shorten the life of the balancer.

Keep all instructions permanently with the unit.

Keep all decals, labels, and notices clean and visible.

To prevent accidents and/or damage to the balancer, use only Hunter GSP9700 Series Road Force Measurement System recommended accessories.

Use equipment only as described in this manual.

Never stand on the balancer.

Wear non-slip safety footwear when operating the balancer.

Keep hair, loose clothing, neckties, jewelry, fingers, and all parts of body away from all moving parts.

Do not place any tools, weights, or other objects on the safety hood while operating the balancer.

ALWAYS WEAR OSHA APPROVED SAFETY GLASSES. Eyeglasses that have only impact resistant lenses are NOT safety glasses.

Keep the safety hood and its safety interlock system in good working order.

Verify that the wheel is mounted properly and that the wing nut is firmly tightened before spinning the wheel.

The safety hood must be closed before pressing the green "START" key, located on the right front corner of the CRT assembly, to spin the wheel.

Hood Autostart will cause the balancer shaft to spin automatically upon hood closure. For the next Autostart, the safety hood has to be lifted to the full up position and then closed.

Raise safety hood only after wheel has come to a complete stop. If safety hood is raised before the spin is completed, the weight values will not be displayed.

Do not let cord hang over any edge or contact fan blades or hot manifolds.

The red "STOP" key, located on the right front corner of the CRT assembly, can be used for emergency stops.

 **DANGER:** Never reach under the hood while the balancer is performing a Road Force™ Measurement or balance spin.

SAVE THESE INSTRUCTIONS.

Electrical

The GSP9700 is manufactured to operate at a specific voltage and amperage rating.

Make sure that the appropriate electrical supply circuit is of the same voltage and amperage ratings as marked on the balancer.

 **WARNING:** DO NOT ALTER THE ELECTRICAL PLUG. Plugging the electrical plug into an unsuitable supply circuit will damage the equipment.

Make sure that the electrical supply circuit and the appropriate receptacle is installed with proper grounding.

To prevent the possibility of electrical shock injury or damage to the equipment when servicing the balancer, power must be disconnected by removing the power cord from the electrical power outlet.

After servicing, be sure the balancer ON/OFF switch is in the "O" (off) position before plugging the power cord into the electrical power outlet.

This device is rated as Class A for radiated emissions.

In the event of radio interference, the display read out may flicker - this is normal.

Decal Information and Placement

Right Side View

Decal 128-963-2 gives the maximum wheel diameter, maximum wheel weight, and maximum rotational frequency for the GSP9700.

Decal 128-605-2-00 cautions the user that spindle rotation may occur with foot pedal depression and to keep clear of clamping components during Quick-Thread™ shaft rotation.

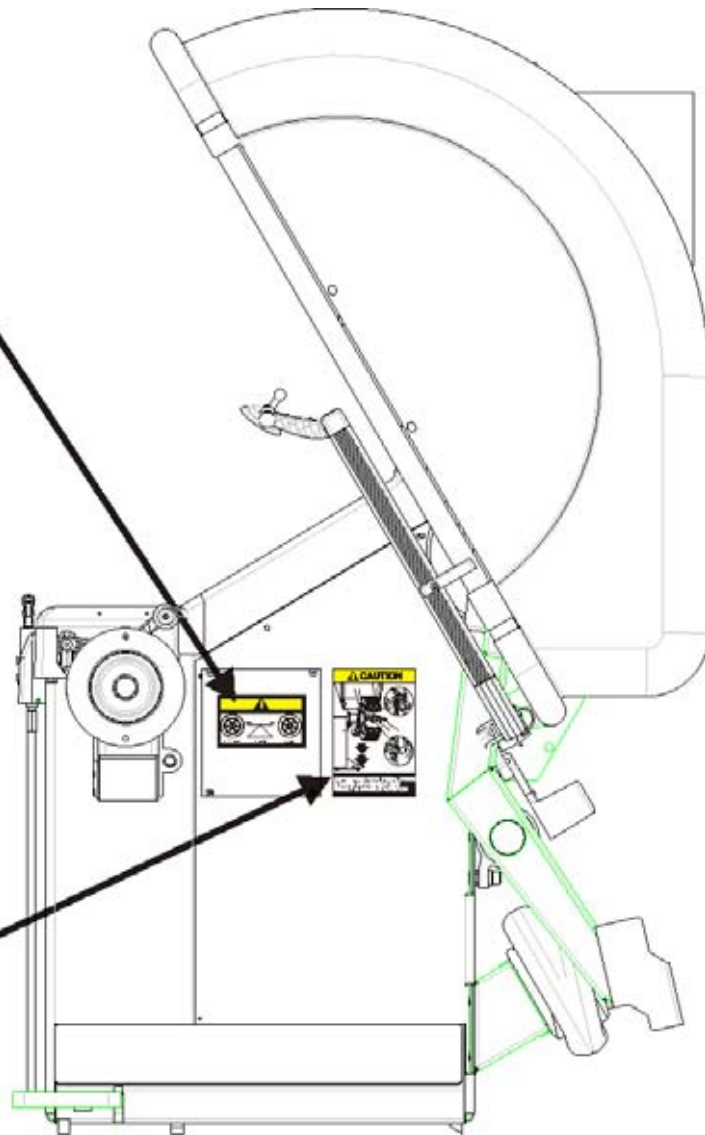
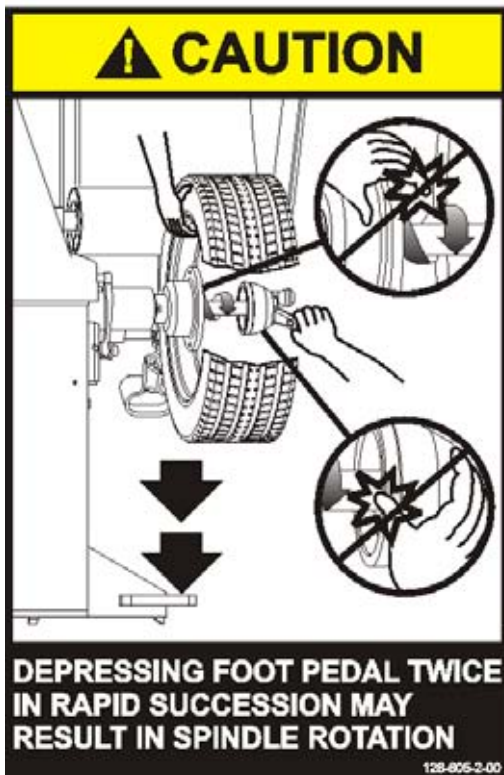
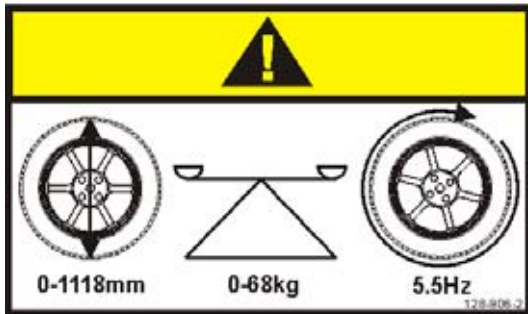

Left Side View

Decal 128-391-2-00 cautions that the unit may automatically start upon closing of the hood when hood Autostart is enabled.

Decal 128-229-2 and decal 128-905-2 work in conjunction to caution the user to not remove the screw because of the risk of electrical shock.

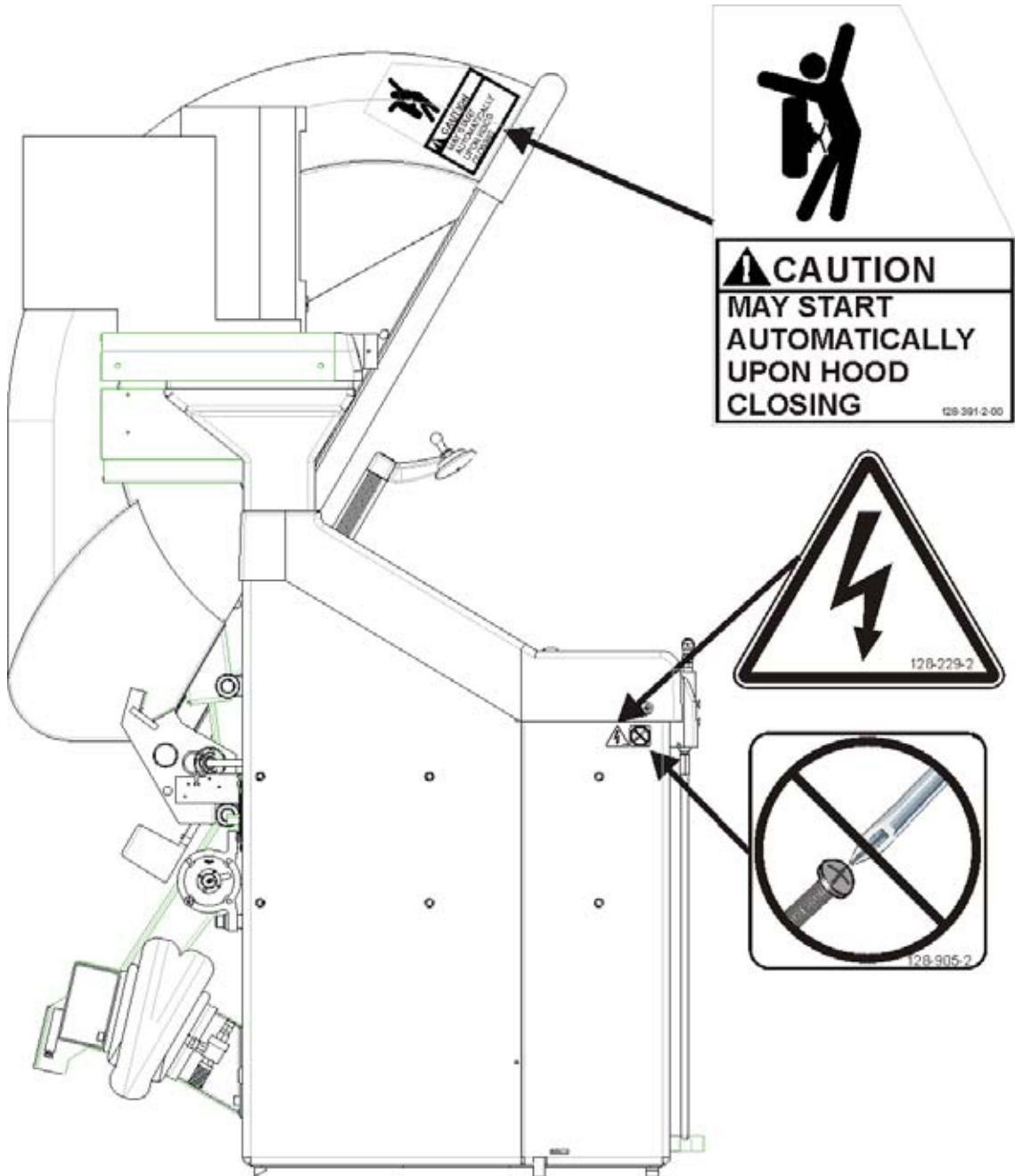

Back View

Decal 128-907-2 warns the user to place the GSP9700 at garage floor level, and not in a recessed area, to avoid the possibility of flammable fume ignition.

Decal 128-229-2 and decal 128-905-2 work in conjunction to caution the user to not remove the screw because of the risk of electrical shock.

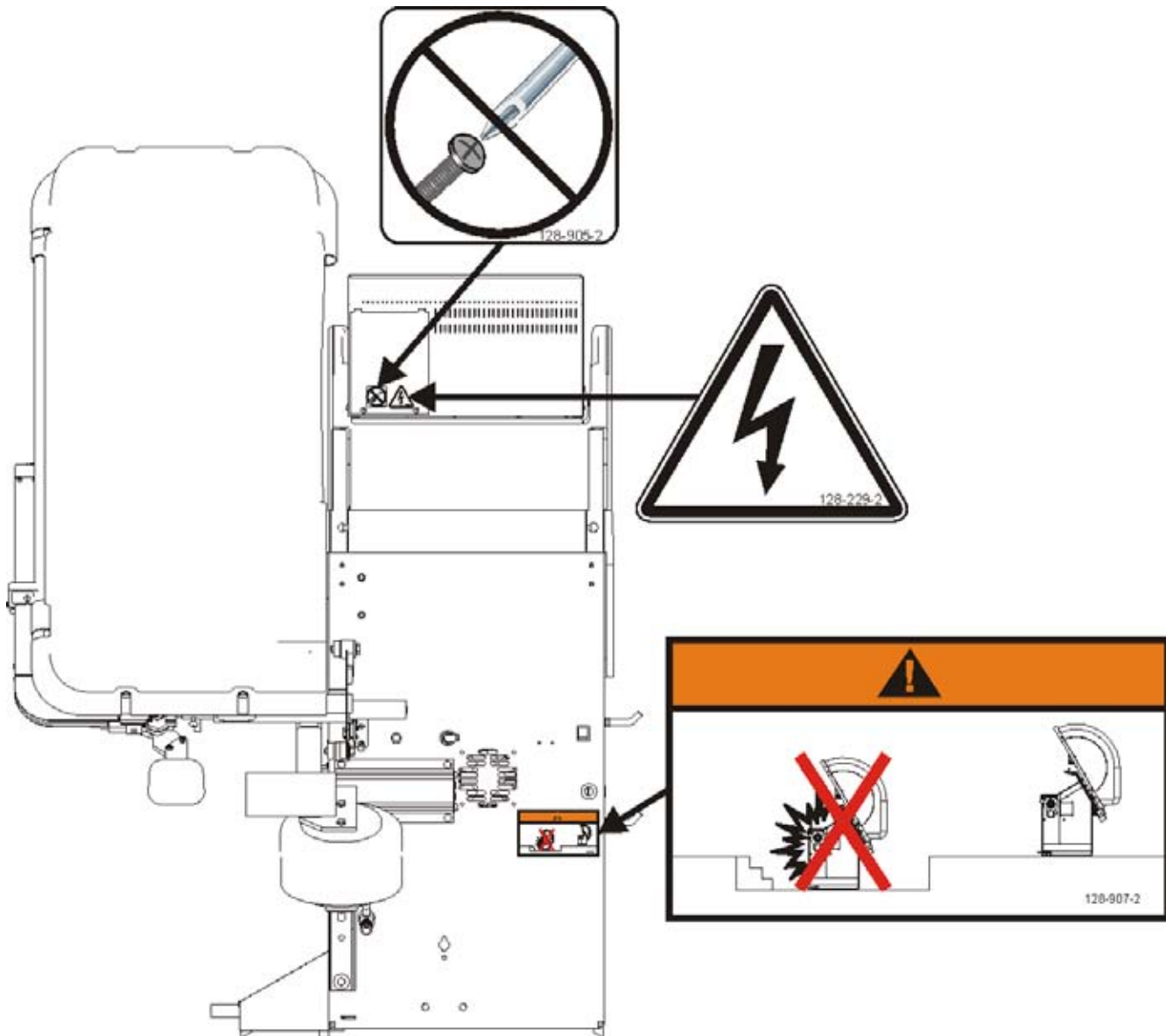

Specific Precautions/Power Source

The GSP9700 is intended to operate from a power source that will apply 230 volts (208 - 240), 1 phase, 50/60 Hz between the supply conductors of the power cord. The power cord supplied utilizes a twist lock connector, NEMA L6-20P. This machine must be connected to a 20 amp branch circuit. Please refer all power source issues to a certified electrician. Refer to "Installation Instructions for GSP9700 Series Road Force Measurement System," Form 4203T (for GSP9702) or "Installation Instructions for GSP9712 Series Road Force Measurement System," Form 4972T (for GSP9712).



CAUTION: A protective ground connection, through the grounding conductor in the power cord, is essential for safe operation. Use only a power cord that is in good condition.

Turning Power ON/OFF

The ON/OFF switch is located on the back of the balancer cabinet. To turn the balancer "ON," press the "I" side of the ON/OFF switch. To turn the balancer "OFF," press the "O" side of the ON/OFF switch.

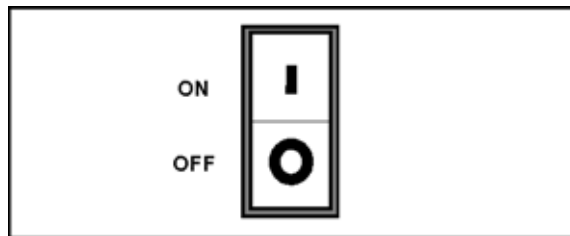

The system requires only a few seconds to "boot up." During "boot up," the system will generate a high-pitched tone until the software is loaded and running.

After the GSP9700 performs a self-check, the "Logo" screen will appear indicating the unit is ready for use.

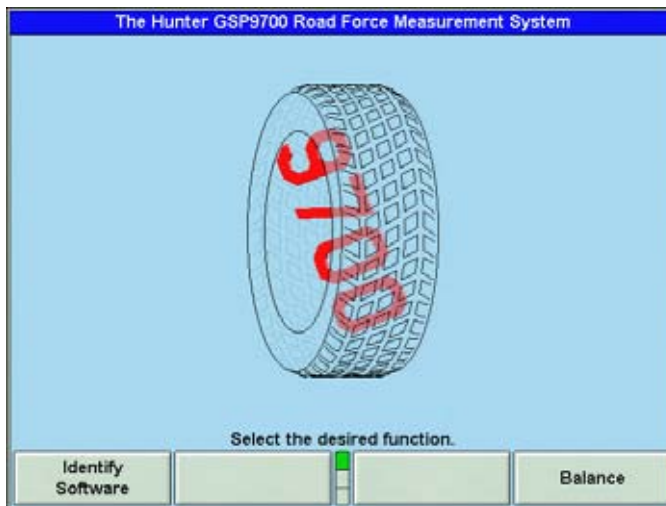

Equipment Installation and Service

A factory-authorized representative should perform installation.

This equipment contains no user serviceable parts. All repairs must be referred to a qualified Hunter Service Representative.

NOTE: To replace program cartridge, refer to "Program Cartridge Removal and Installation," page 103.

Equipment Specifications

Electrical

Voltage: 230 volts (208 - 240), 1 phase, 50/60 Hz

Amperage: 15 amperes

Wattage: 3450 watts (peak)

Air

Air Pressure Requirements: 100-175 PSI (6.9-12.0 bar)

Approximate Air Consumption: 4 CFM (110 Liters/Minute)

Atmospherics

Temperature: +32°F to +122°F (0°C to +50°C)

Relative Humidity: Up to 95% Non-condensing

Altitude: Up to 6000 ft. (1829 m)

Sound Pressure Level

Equivalent continuous A-weighted sound pressure at operator's position does not exceed 70 dB (A).

Safety Summary

Explanation of Symbols

These symbols may appear on the equipment.



Alternating current.



Earth ground terminal.



Protective conductor terminal.



ON (supply) condition.



OFF (supply) condition.



Risk of electrical shock.



Stand-by switch.



Not intended for connection to public telecommunications network.

1.3 Equipment Components



GSP9712

Standard Balancer Accessories

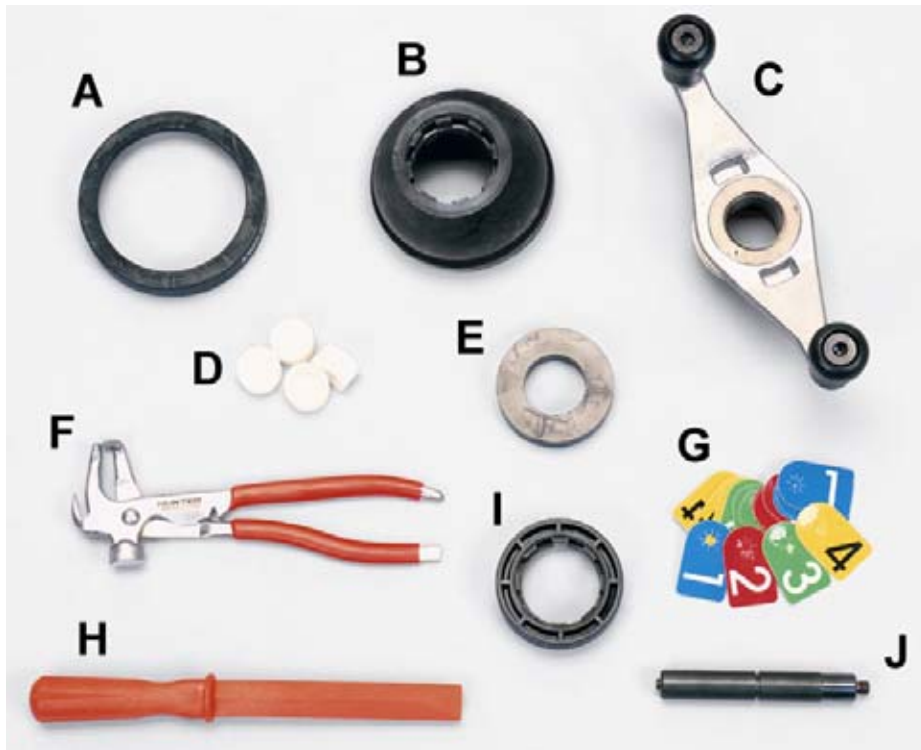

A.	106-82-2	Sleeve, Scratch Guard for Small Cup
B.	175-353-1	Polymer Cup (4.5" O.D.)
C.	76-371-3	Quick Take-Up Wing Nut with Handles
D.	221-658-2	Hammer Heads (4)
E.	46-320-2	Spacer
F.	221-589-2	Weight Hammer/Pliers
G.	20-1650-1	Rim Tags
H.	221-659-2	Adhesive Weight Scraper
I.	223-68-1	Pressure Ring
J.	65-72-2	Calibration Weight

NOTE: Hunter wheel balancers do not include a standardized set of mounting adaptors.

For optional accessories, refer to *Wheel Balancer Brochure, Form 3203T*.

1.4 Operating the Console

Using Softkeys

The “softkeys,” located on the CRT support console directly beneath the CRT, provide operator control of the balancer. The keys are identified as:

	K1 key
	K2 key
	K3 key
	K4 key
	Menu shift key
	Start key
	Stop key
	Reset key

The four menu labels that appear at the bottom of each video screen are referred to as the “softkey labels.” Each label indicates the action that the program takes when the corresponding K1, K2, K3, or K4 key is pressed.

The display between the “K2” and “K3” labels indicates how many rows of labels are available. Most screens have only one or two rows, however more rows are possible. The green box indicates the row that is currently displayed.

The menu row is changed by pressing the menu shift key, . When this key is pressed, the menu labels change to the next row down. If the last row is currently displayed, the menu labels change to the first row.

Throughout this manual, the statement press “nnnnnn” means press the softkey with the label “nnnnnn.” If the required label is not on the current menu, press  to change rows until the desired label is displayed.

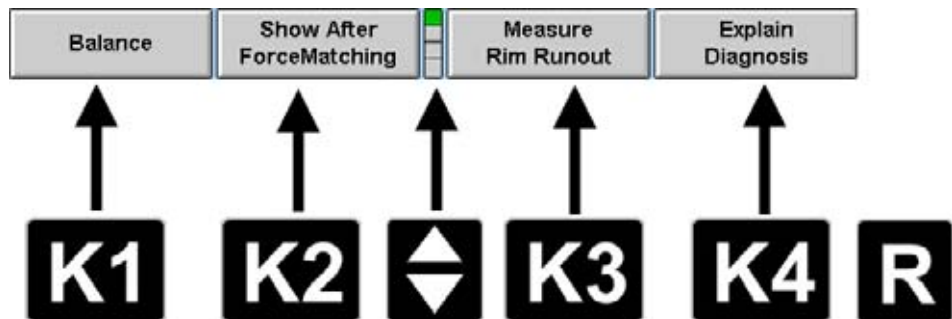

Primary Balancing Display

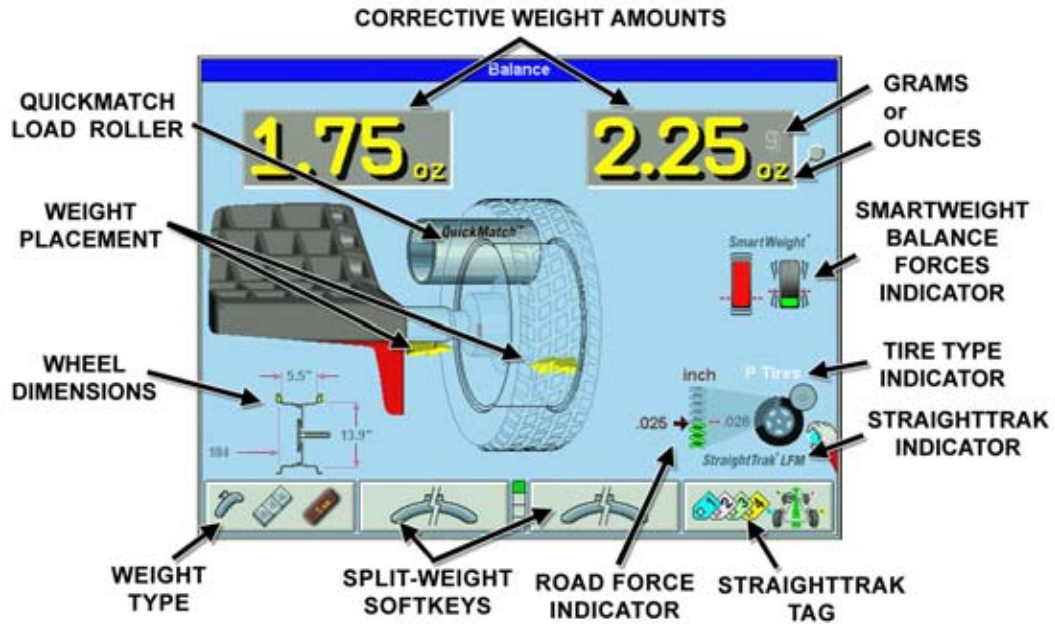

Using the Control Knob (GSP9712)

The control knob is located to the right of the softkeys. The control knob is used to control the on-screen switches and manually input data. The on-screen switches that are available are dependent upon the setup configuration of the balancer.

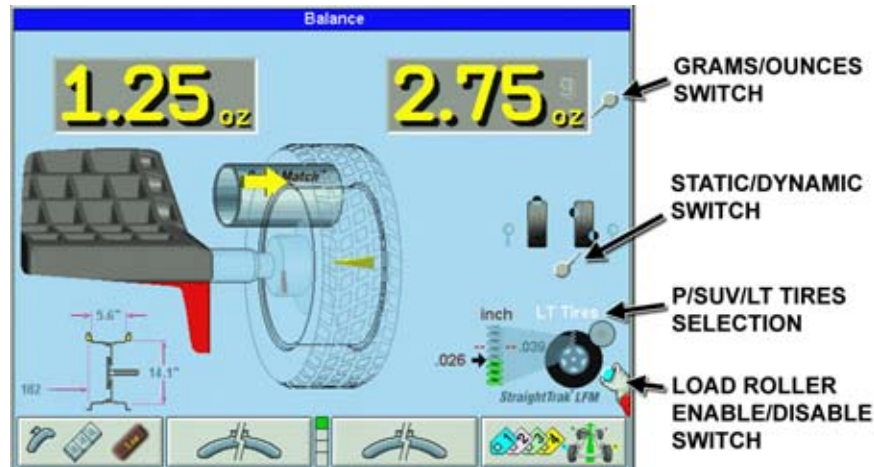
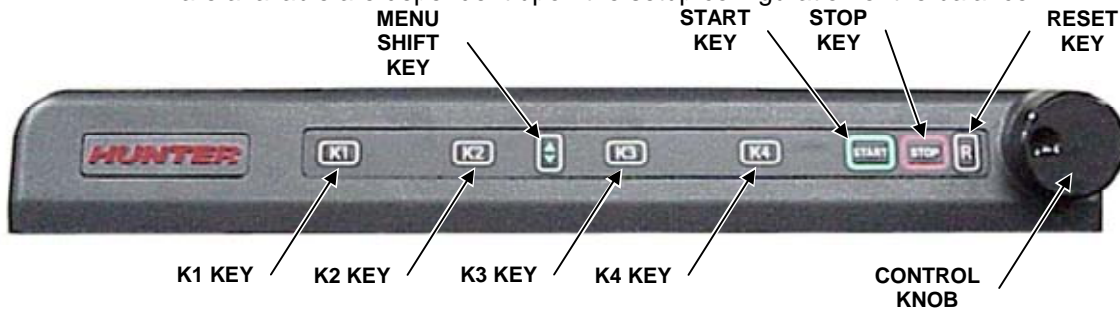

CONTROL KNOB ACCESSED ON-SCREEN SWITCHES

Pushing in on the control knob cycles through the on-screen switches that are available on the current primary screen. Rotating the control knob clockwise or counter-clockwise changes the setting for the selected on-screen switch.

For example, in the "Balance" primary screen, pushing in on the control knob will cycle through the grams to ounces, the static and dynamic, and the load roller on-screen switches. After selecting an on-screen switch, the setting may be selected by rotating the control knob. The "selected" switch is the one showing the hand.

Using Control Knobs (GSP9702)

The control knobs are located to the right of the CRT screen. The control knobs are used to control the on-screen switches and to manually input data. The control knobs are identified as the upper, middle, and lower control knobs. The on-screen switches that are available are dependent upon the current mode of the balancer.

For example, in the “Balance” primary screen, the upper knob (1) controls the grams to ounces on-screen switch. The middle knob (2) controls the static, dynamic and non-rounding on-screen switch, and the lower knob (3) controls the load roller and P/LT tires on-screen switch.

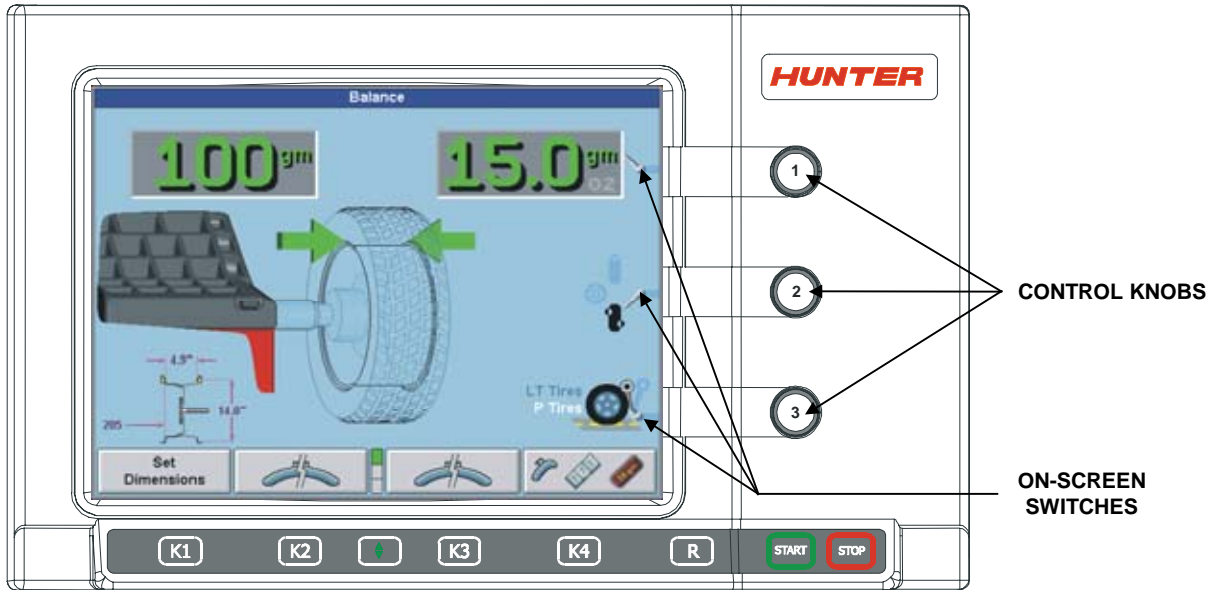

Resetting the Program

The wheel balancing program may be reset at anytime by using the “**R**” key, located on the CRT support console directly beneath the CRT. To reset the balancer, press the reset key twice within a four-second period without pressing any other keys in-between. This prevents a single accidental keystroke from resetting the system.

When the balancer is reset, the information collected for the wheel balance in progress is erased and the display returns to the “Logo” screen.

Using the Screen Saver/Merchandising Display

If the CRT displays the same image for a long time, the image may become “burned in” and will be visible even when the display is turned “OFF.” This is a characteristic of *all* computer CRT displays. Therefore, after the designated time has passed, the screen saver will appear on the CRT if “Screen Saver” is not disabled.

NOTE: The system is still running when the screen saver is enabled.

When any “softkey” is pressed or the spindle turned, the program will reappear on the CRT. This keystroke or spindle movement is recognized only by the screen saver program and will not affect the balancer program. After the screen is on, additional key presses will operate the program normally.

NOTE: The screen saver is not affected by rotating the control knob(s).

2. Balancing Overview

2.1 Balancing Modes

SmartWeight™ Balancing Technology

SmartWeight™ balancing technology is a method of reducing forces on a wheel during balancing. This results in less weight used, and less time balancing tires.

SmartWeight is not a procedure. Instead, it measures the forces of side-to-side shimmy and up-and-down shake and computes weight to reduce these forces. This reduces the amount of weight, reduces time, reduces check spins and chasing weights, and saves the shop time and money.

SmartWeight can reduce the number of steps in the balancing process.

Balancing Theory

Static Imbalance

As the word static implies, the tire will be balanced when at rest. For example, if an unmoving assembly was centered on a cone and was balanced, it would be statically balanced. A “bubble balancer” is designed to statically balance a tire/wheel assembly.

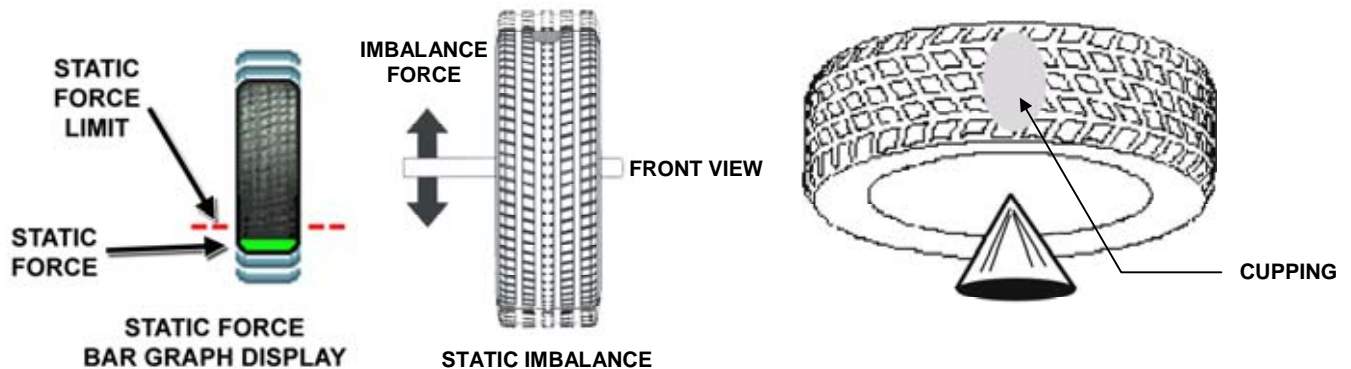

Static imbalance is where there is one amount of weight located in the center of the tire/wheel assembly causing an imbalance. As the weight rotates, centrifugal forces are created causing the wheel to lift as the weight reaches top dead center. This lifting motion causes the tire/wheel assembly to move “up and down” creating a bounce to be felt. This static imbalance condition is evident by a “jiggle” or up-down movement of the steering wheel. These vibrations may also be apparent in the body, with or without steering wheel shake.

A statically imbalanced tire driven for an extended period may cause “cupping” in the tire’s tread, create vibration, and adversely effect handling.

Static balancing alone is a seldom-recommended procedure. For example, a single weight is commonly placed on the inner clip weight position for cosmetic purposes. This is not a recommended practice and usually insures the assembly is not properly dynamically balanced. The assembly may then experience side-to-side imbalance while in motion, causing a shimmy condition and objectionable vibration.

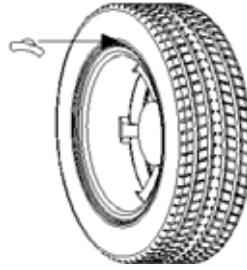

Couple Imbalance

In general terms, dynamic imbalance is defined as where one or more locations of the tire/wheel assembly are heavier causing an imbalance force and/or an imbalance wobble. Shown below is a tire/wheel assembly with two heavy spots of equal weight which are located 180 degrees radially from each other on opposite sides. As this assembly rotates, centrifugal forces cause a large imbalance wobble to be created, but the imbalance force (as well as the static imbalance) will be zero. A wheel with this condition will cause a wobble or shimmy to be felt in the steering wheel. Excessive dynamic imbalance of this type creates a shimmy that transfers through the suspension components to the occupants of the vehicle, especially at higher speeds.

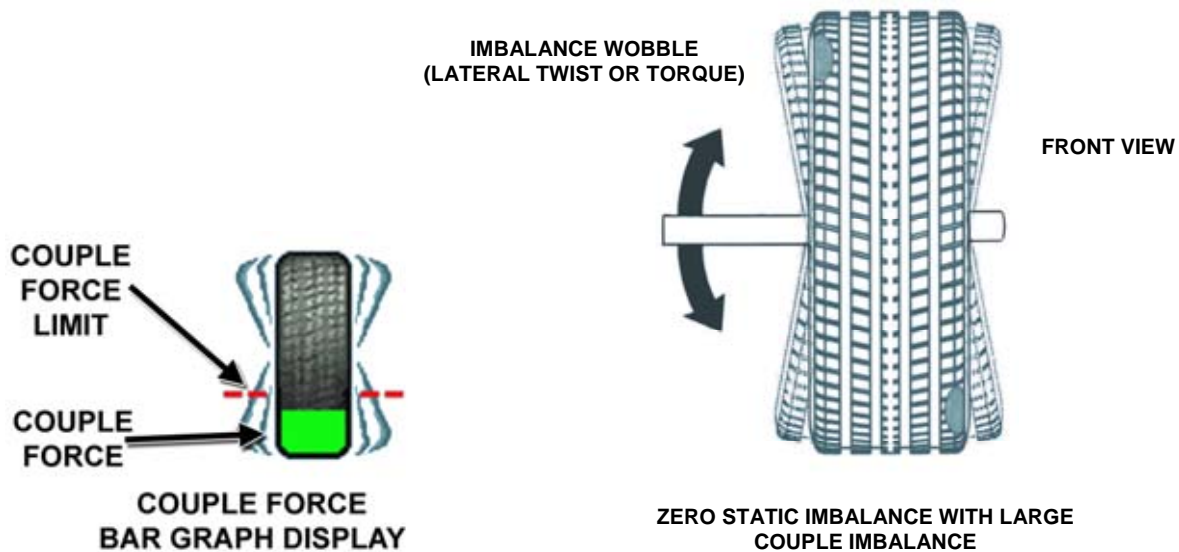

Modern “dynamic” balancers spin the wheel in order to measure both the up and down imbalance force and the wobble or shimmy related imbalance (side-to-side).

Dynamic balancers direct the operator to place correction weights on the inside and outside correction locations of the rim so that both imbalance shake (static) and imbalance wobble (couple) will be eliminated.

SmartWeight may also utilize a single weight placement to balance out shake and shimmy forces.

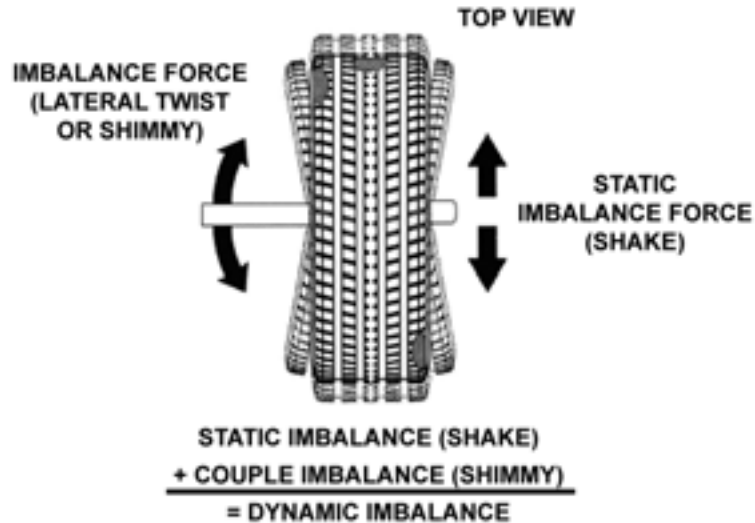

Static and Dynamic Imbalance Sensitivity

As a general rule of thumb, to achieve the best balance on an average sized tire and wheel (15x6) assembly.

Residual static imbalance should be less than 1/4 ounce.

Residual couple imbalance should be less than 3/4 ounce.

Residual couple imbalance is preferred over remaining static imbalance.

It takes much more residual couple imbalance to cause a vibration than the same amount of static imbalance.

The larger the diameter used for weight placement, the smaller the amount of correction weight is required.

The wider the distance between the two weight placement locations, the smaller the amount of correction weight is required.

If static balance is the only option, always verify that the remaining couple residual imbalance is within acceptable tolerance.

For detailed information on adjustment and setup of modes of wheel balancing sensitivity see section 5.1 and section 6.4.

2.2 Identifying the Static Balance Weight Plane

In "STANDARD BALANCE" mode, using only a clip-on weight, the plane is input as follows:

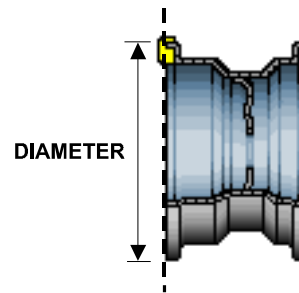

For static balancing, it is recommended that you place half of the correctional weight value on each side of the tire to reduce residual dynamic imbalance.

In "MIXED WEIGHTS BALANCE" mode and "ADHESIVE WEIGHTS BALANCE" mode, using an adhesive weight, the plane is input as follows:

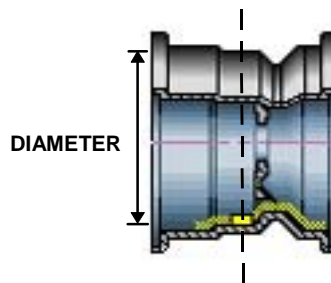

For static balancing, it is recommended that the adhesive weight be placed as close to the center of the wheel as possible to reduce residual dynamic imbalance.

In "PATCH BALANCE" mode, using a patch weight, the plane is input as follows:

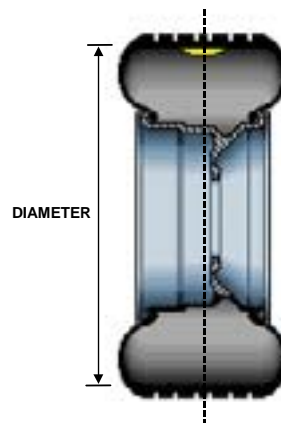

For static balancing, it is recommended that the patch weight be placed as close to the center of the tread as possible to reduce residual dynamic imbalance.

2.3 Identifying the Dynamic Balance Weight Planes

The balancer must know the location of the two weight circle planes for placement of correction weights on the wheel assembly.

Each plane is described by a distance from the balancer and a diameter.

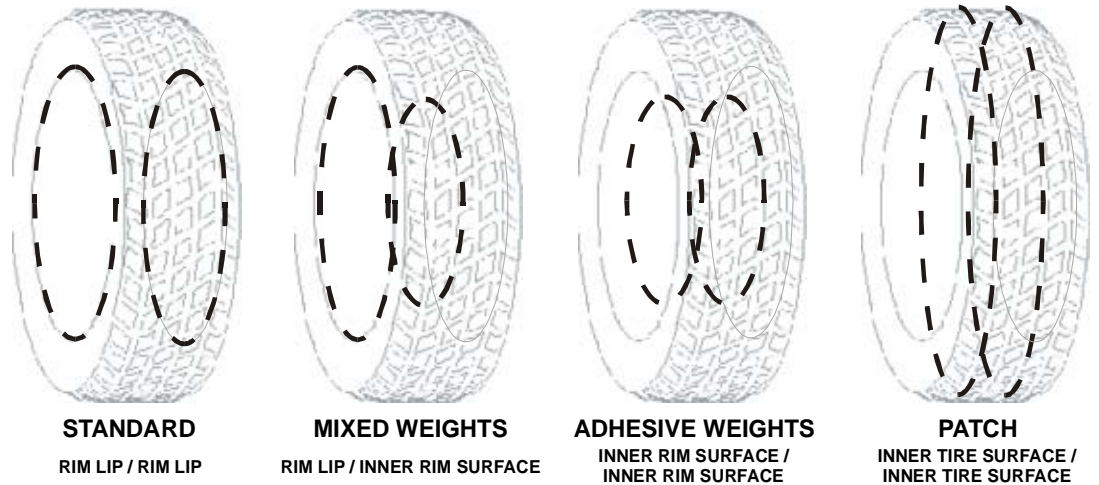

In “STANDARD BALANCE” mode, using only clip-on weights, left and right planes are input as follows:

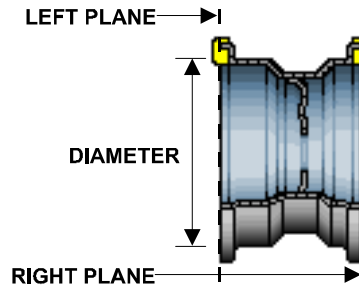

In “MIXED WEIGHTS BALANCE” mode, using clip-on and adhesive weights, the left and right planes are input as follows:

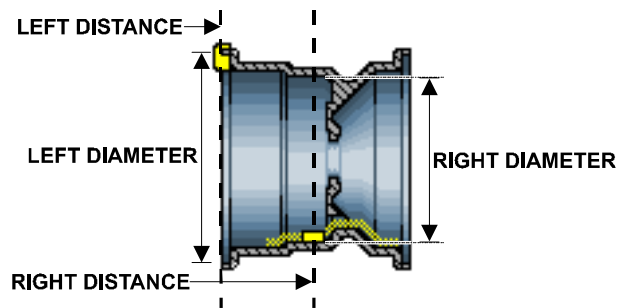

In “ADHESIVE WEIGHTS BALANCE” mode, left and right planes are input as follows:

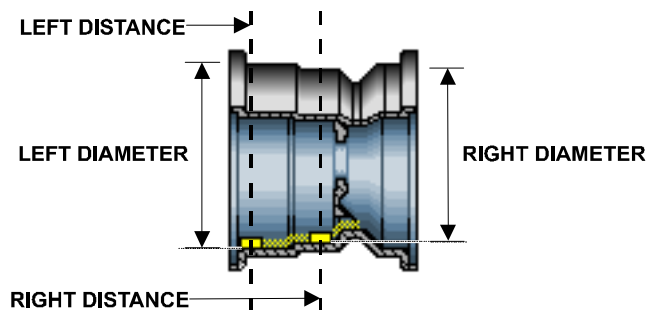

In "PATCH BALANCE" mode, using patch weights, left and right planes are input as follows:

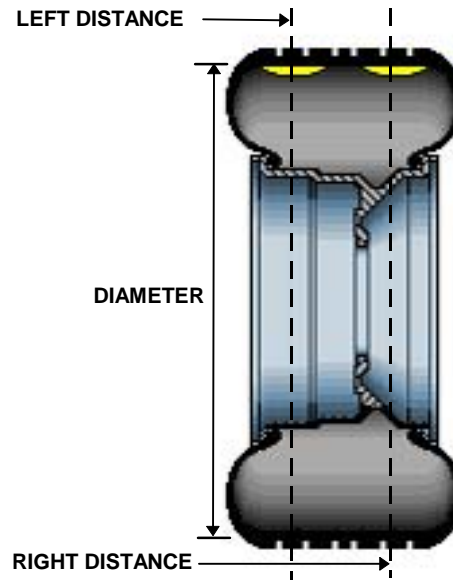

2.4 SmartWeight™ Dynamic Weight Planes

SmartWeight requires the operator to enter two weight planes. This balancing method will automatically determine if one or both weight planes require a weight to be added. This eliminates "blinded" static single plane balancing, which alone may not be sufficient to solve vibration issues.

3. Mounting Wheels on the Balancer

3.1 Mounting the Wheel Using Wheel Lift (Optional)

The Wheel Lift is an optional feature on the GSP9700 series balancer. For instructions on mounting the tire/wheel assembly without the optional wheel lift, refer to "Mounting the Wheel," page 23.

Raising the Tire/Wheel Assembly

Press the lift control handle "down" until the trolley carriage is at its lowest level.

Slide the appropriate mounting cone onto the spindle.

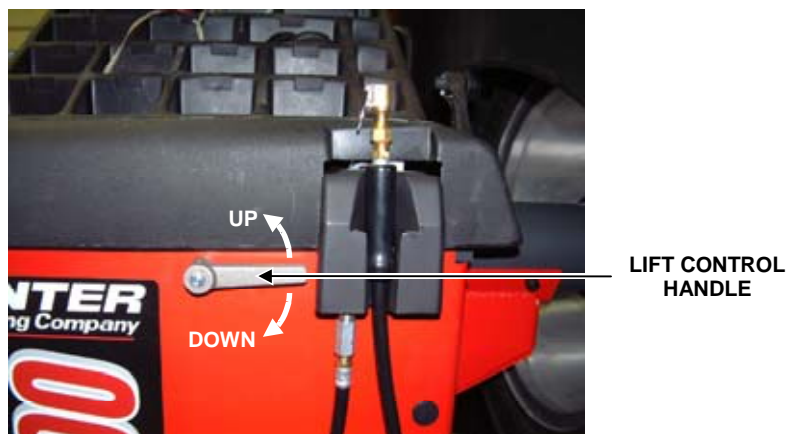

With the trolley carriage extended all the way out to the right, roll the tire/wheel assembly onto the trolley carriage.

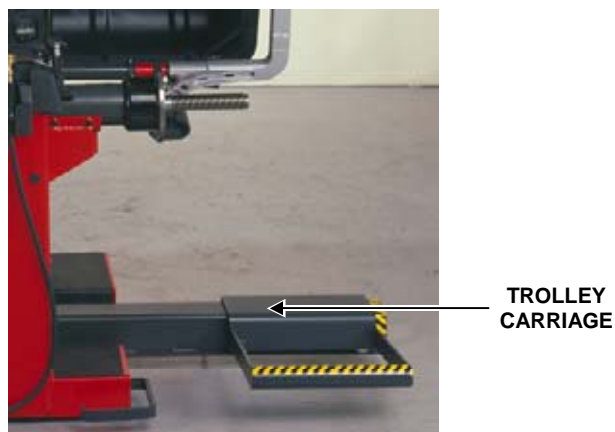

Raise the lift control handle "up" to move the lifting beam and trolley into a position where the tire/wheel assembly can be installed onto the spindle.

Slide the tire/wheel assembly onto the spindle and center on the mounting cone. Verify that the tire/wheel assembly is centered vertically on the spindle. Refer to "Mounting the Wheel," page 23.

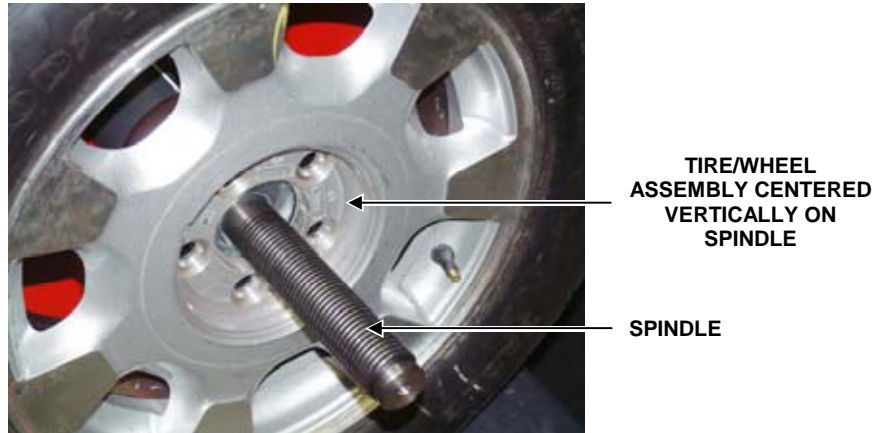

Install the clamping cup and wing nut on the spindle shaft against the wheel and secure the entire assembly by firmly tightening the wing nut, while depressing the foot pedal to hold the spindle in place.



With the tire/wheel assembly secured to the GSP9700, press the lift control handle "down" until the trolley carriage is at its lowest level.

NOTE: The trolley carriage will also retract to its lowest level automatically when the hood is closed.

Service the tire/wheel assembly as necessary. Refer to "Balancing a Wheel," page 35 for specific operation instructions.

Lowering the Tire/Wheel Assembly

Raise the hood.

Lift the lift control handle “up” to move the lifting beam and trolley into position to support the tire/wheel assembly.

Step on the Spindle-Lok[®]/foot pedal of the GSP9700, and then loosen the wing nut that secures the clamping cup.

With the wheel lift supporting the tire/wheel assembly, steady the tire/wheel assembly with your left hand, and remove the wing nut and clamping cup with your right hand.

Slide the tire/wheel assembly to the right, so that it clears the spindle shaft.

Press the lift control handle “down” until the trolley carriage is at its lowest level.

Roll the tire/wheel assembly off the carriage trolley.

3.2 Mounting the Wheel (Without Wheel Lift)

 CAUTION: Use only cones and accessories that are specifically designed for the GSP9700 Series Road Force Measurement System.

Since today’s vehicle designs are more sensitive to road feel, it is critical to achieve the best balance. Proper balance requires that the tire/wheel assembly be centered on the balancer. Tire/wheel assemblies can be balanced to zero, even with the tire/wheel assembly mounted off-center. The main objective of the balancer operator is to center the wheel on the hub and shaft, using the best available method. Mounting the wheel off-center creates incorrect measurements of imbalance and runout conditions.

Remove any existing wheel weights, rocks, and debris from the tire tread, and clean the center hole of the wheel. Inspect inside of wheel for excessive accumulation of dirt and debris. Remove if necessary before balancing.

Accurate balancing depends on accurately centering the wheel. Choose the proper wheel mounting cone by placing it in the center hole of the wheel to be balanced. Refer to “CenteringCheck[®],” page 30.

NOTE: If the basic cone and adaptors do not fit the wheel, additional centering adaptors will be necessary. A wheel that cannot be properly centered, cannot be properly balanced. All balancers require additional centering adaptors to properly center certain types of wheels. For additional information, refer to Form 3203T for optional accessories.

With the safety hood open, place the wheel mounting cone on the spindle shaft against the captivated spring. Position the wheel with the inside surface facing the balancer, centered on the cone.

Install the plastic clamping cup and wing nut on the spindle shaft against the wheel and secure the entire assembly by firmly tightening the wing nut.

If equipped with optional Spindle-Lok[®] foot pedal, depress and hold down while tightening the wing nut. Holding the shaft locked while tightening the wing nut improves centering accuracy.

Slowly roll the wheel towards you while tightening the wing nut. This improves accurate wheel centering, since the wheel is allowed to roll up the taper of the cone as opposed to forcing it to slide up the cone.

Mounting Error Detection Features

To verify that the tire/wheel assembly is centering, remount the tire/wheel assembly and observe the results. Do any of the following conditions occur?

- Weight amount varies excessively
- Weight location changes
- Runout and road force measurements vary excessively

If any of these conditions occur, the centering accuracy of the tire/wheel assembly needs to be verified.

There are two methods using wheel runout that the GSP9700 will utilize to detect mounting error:

- Anytime the wheel runout is measured, the displayed diagnostic message may caution the operator to check wheel mounting if runout on inner and outer bead seats move up and down or side to side together.
- From the balance screen, the operator can choose to perform a CenteringCheck[®]. The CenteringCheck[®] feature will automatically confirm if the wheel is centered for the operator on the balancer (preventing improper measurement from occurring).

See page 30, *CenteringCheck[®]*, for a detailed description of the feature.

Front/Back Cone Mounting

Cone mounting is one of the most common and reliable ways to mount wheels on balancers. Select the proper wheel mounting cone by placing it in the center bore of the wheel to be balanced. Select the cone that contacts the wheel nearest the center of the cone.

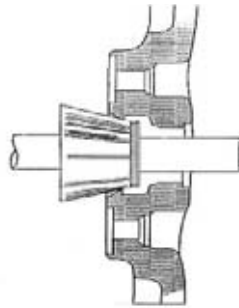

Place the wheel mounting cone on the spindle against the spring plate. Mount the wheel with the inner rim facing the balancer and centered on the cone.

Install the clamping cup and wing nut on the spindle shaft against the wheel and secure the entire assembly by firmly tightening the wing nut, while depressing the foot pedal to hold the spindle in place.

NOTE:

If equipped with optional Spindle-Lok® foot pedal, depress and hold down while tightening the wing nut. Holding the shaft locked while tightening the wing nut improves centering accuracy.
Slowly roll the wheel toward you during the initial tightening of the wing nut. This aids in accurate wheel centering and increased repeatability, since the wheel is allowed to roll up the taper of the cone as opposed to forcing it to slide up the cone.

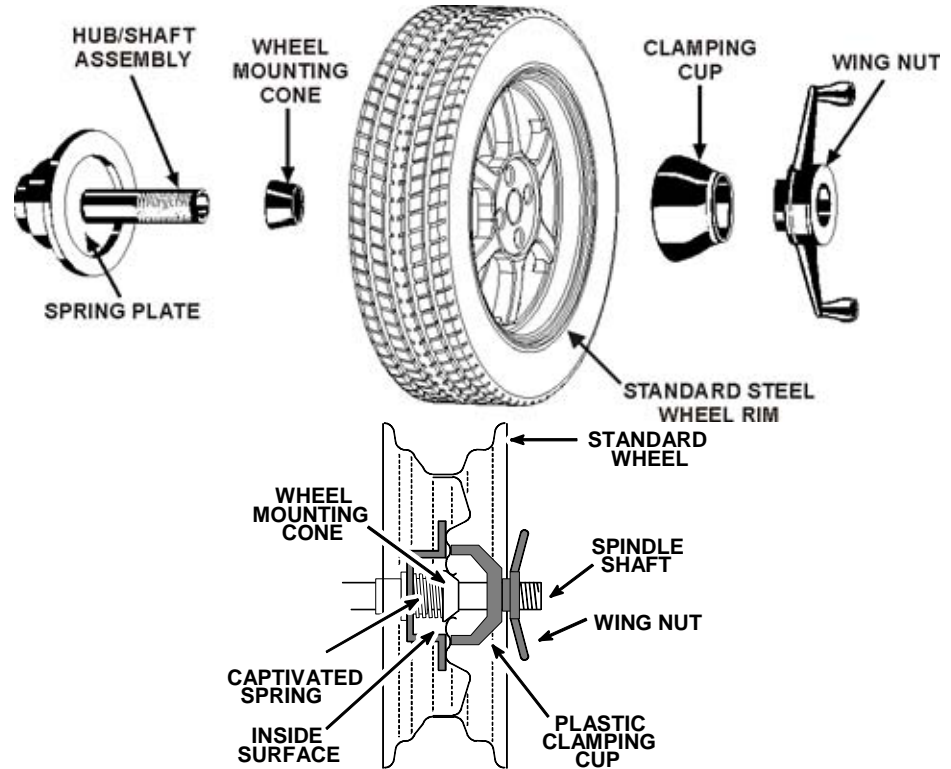

Wheels with center holes over 3 9/16 inch diameter require the light truck cone. The light truck cone can be installed from the outside of the wheel. (When using the light truck cone, the plastic clamping cup is not used.)

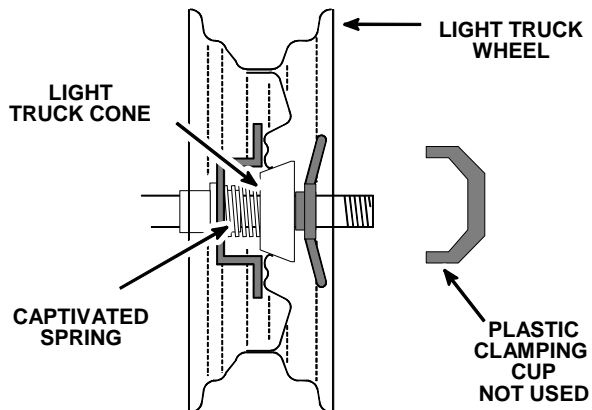

Using Plastic Wheel Mounting Washer

The plastic wheel mounting washer, 46-320-2, is used to prevent scratches on wheels where the standard plastic cup and scratch guard cannot be used. The plastic wheel mounting washer can also be used when mounting a wheel with a large offset that is between cone sizes. Use of the washer as shown below can improve centering ability by increasing cone pressure against the wheel.

For example: One cone size is too small because the captivated spring is not pressing the cone against the inner wheel opening, but the next larger cone size is too big and will not fit the opening. Use the smaller cone size with the plastic wheel mounting washer to "extend" the captivated spring to hold the mounting cone against the wheel opening with greater pressure.

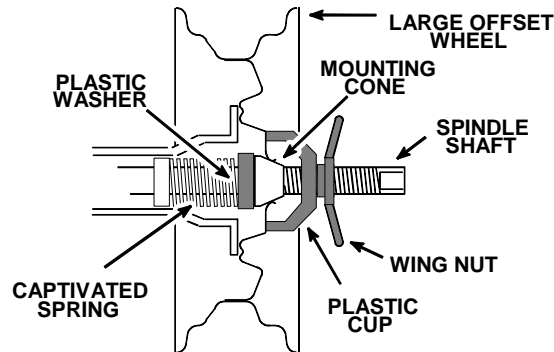

The scratch guard may be installed on the clamping cup to protect aluminum rims from being marred, but should not be used on steel wheels.

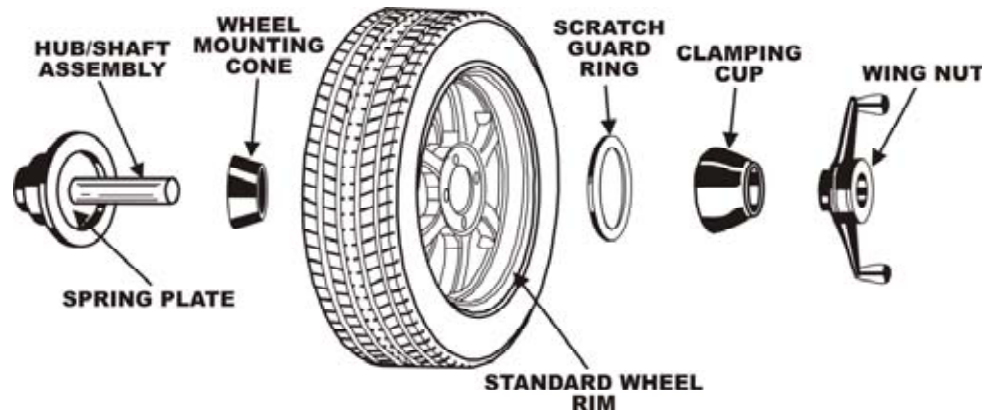

NOTE: Use only the wing nut supplied with the GSP9700.

In some cases, the mounting pad of the wheel may be extremely wide, and the standard clamp cup will not properly contact the wheel hub area. In these cases, the optional nine-inch alloy wheel pressure cup may be used in place of the clamping cup.

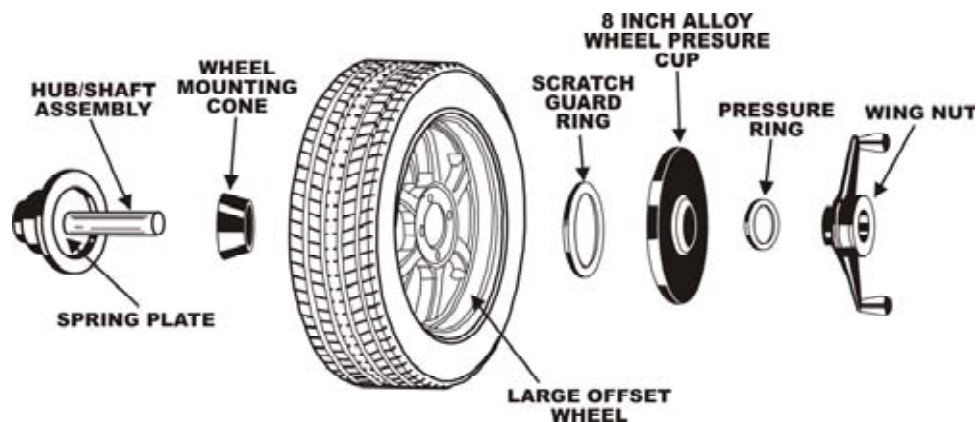

Wheels with center bores over 3 9/16 inch diameter require one of the light truck cones. The light truck cones must be mounted from the outside of the wheel.

NOTE: When using the light truck cones, the pressure ring is used in place of the clamping cup.

This procedure utilizes a tapered cone inserted from the front side of the wheel instead of the backside as previously described.

Select the proper wheel mounting cone by placing it in the center bore of the wheel to be balanced. Choose the cone that contacts the wheel nearest the center of the cone.

Mount the wheel with the inner rim facing the balancer. Place the wheel mounting cone on the spindle with the small end of the cone facing the front of the wheel.

Install the wing nut and pressure ring assembly onto the spindle shaft against the wheel and secure the entire assembly by firmly tightening the wing nut.

Heavy wheel centering may benefit by (1) pulling the tire away from the hub face at top dead center while tightening the wing nut or (2) use of optional wheel lift to position heavy wheel onto shaft and cone. This helps the wheel to overcome gravity against the hub or spacer.

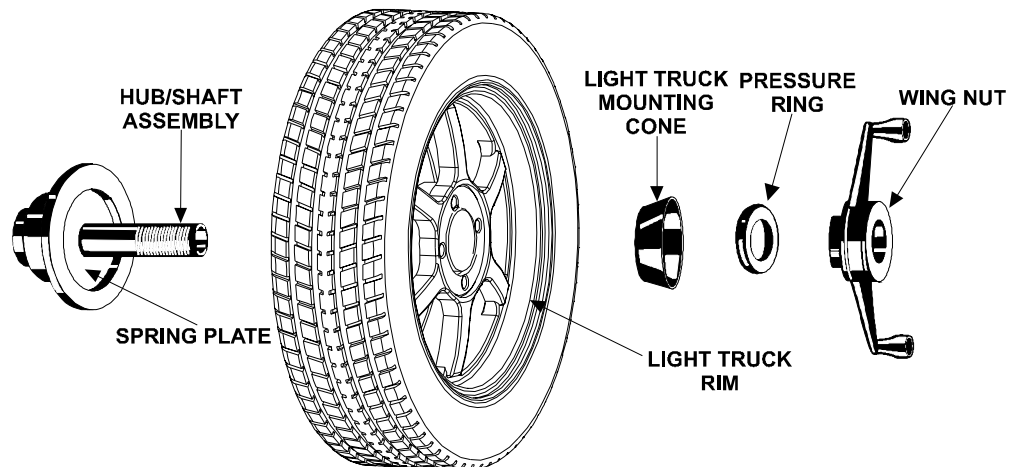

Cone/Flange Plate Mounting

Wheels may be centered using the lugholes and center bore with a flange plate and centering cone. It is important that a back mounted cone be used to support and center the wheel when using flange plates.

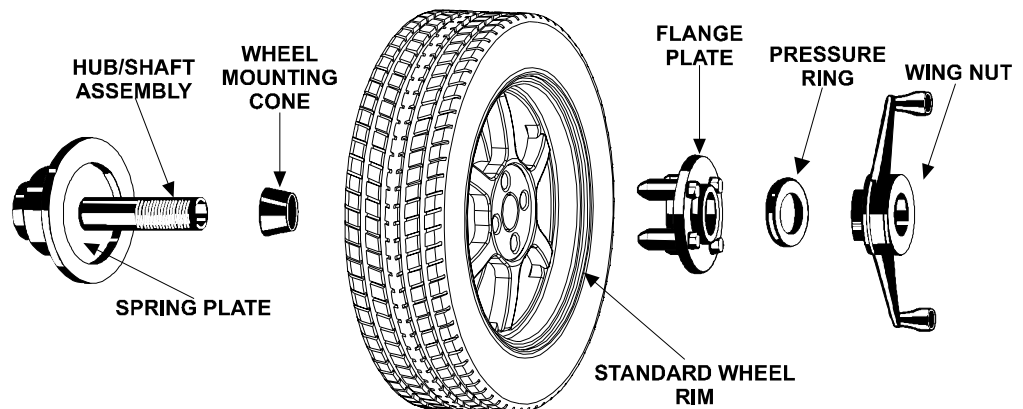

The correct flange adaptor setup is determined by:

Measure and set the bolt circle diameter and number of studs to use against the lug holes.

Set the number of lugholes as follows:

A three-lug wheel uses three studs.

A four-lug wheel uses four studs.

A five-lug wheel uses five studs.

A six-lug wheel uses three studs.

A seven-lug wheel uses seven studs.

An eight-lug wheel uses four studs.

Choose the correct taper design of flange studs to fit the wheel lug seats. The mounting area of the flange stud must match the design of the wheel's lughole seat or depression.

The flange plate must be able to apply pressure to the center of the wheel while maintaining perpendicularity to the shaft.

NOTE:	If the lug seats are unevenly machined or worn, an optional universal flange adaptor with compressible studs or bolt on lugs may be used to more accurately mount the wheel with the cone.
--------------	--

Flange plates are useful when the wheel cannot be properly centered off the hub bore with a tapered cone alone because of improper fit, interference, or lack of a center hole.

A flange plate in many cases adds value because it aids in more effective centering than a tapered cone alone. This statement is true for many wheels including hub centric wheels. That is why a flange plate and back cone may be more accurate and repeatable, regardless of whether the wheel is lug centric or hub centric.

Expandable Collet Mounting

An expandable collet should **NOT** be used with the GSP9700 due to the amount of force applied by the load roller.

Using the Pressure Ring and Spacers

Pressure Ring

The pressure ring clips on to the wing nut. It is used in lieu of the clamping cup.

It may also be used in place of a clamping cup if space is limited between the wheel and the end of the spindle.

The pressure ring should be used to prevent the wing nut from directly contacting an adaptor or a cone. It will act as a bearing to enable higher clamping forces.

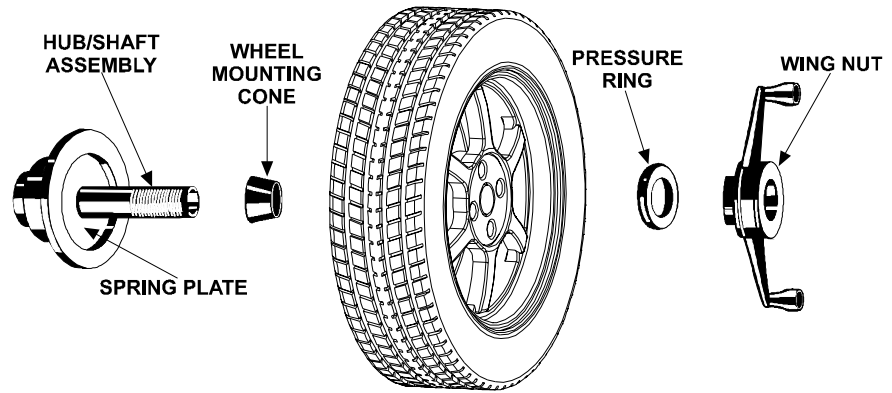

Spacers

Hub Ring Spacers

These light truck spacers are designed to build a larger pocket when using extra large truck cones. It also provides a location for the centering pins found on some dual wheel configurations.

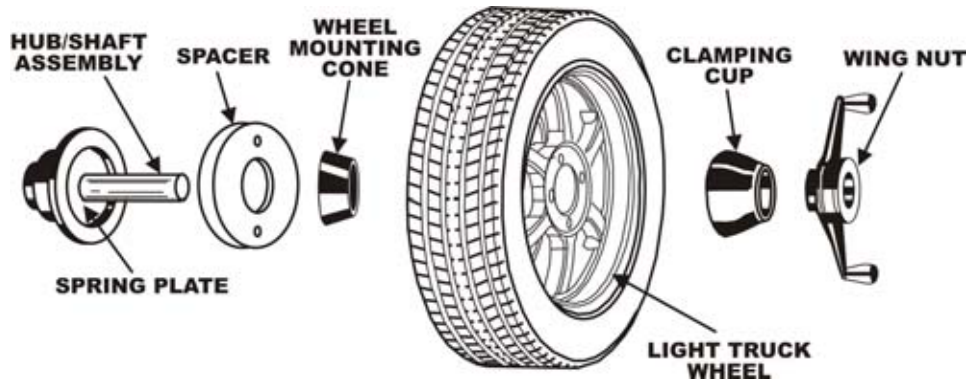

Shaft Spacers

The shaft spacer can be used to make the cone contact the hub bore more firmly.

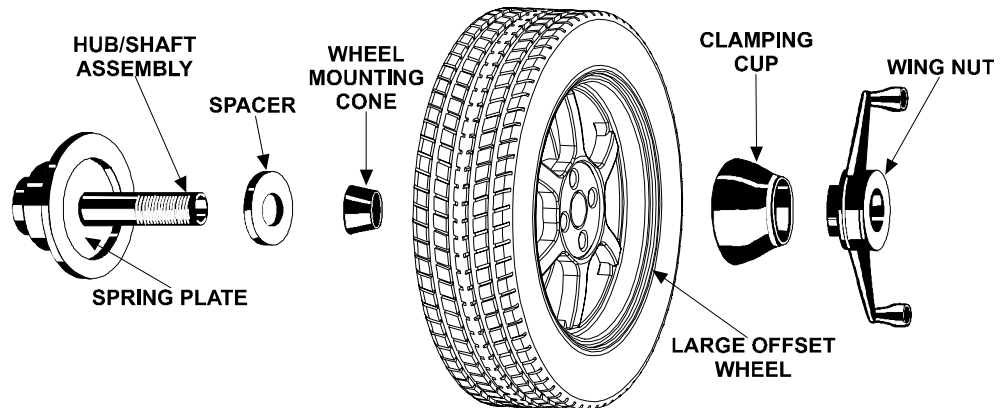

For example, one cone size is too small because the captivated spring is not pressing the cone against the inner wheel opening, but the next larger cone size is too large and will not fit the opening. Use the smaller cone size, with the spacer, to extend the captivated spring and hold the smaller mounting cone against the wheel opening with greater pressure.

CenteringCheck®

The CenteringCheck® feature can be used to inspect each mounting to identify possible centering errors, thus preventing improper measurements from occurring. The inner Dataset® arm, is used to measure wheel runout which is an indication of mounting repeatability.

CenteringCheck® may be used with either a “bare rim” or a “rim with tire assembly.” On-screen prompts lead you through the procedure as follows:

Select “Perform Centering Check” from the menu.

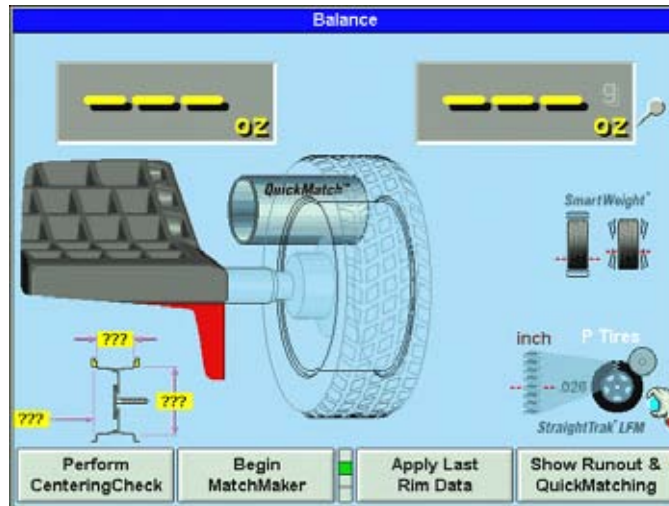

Place the inner Dataset® arm against the rim at a location that will maintain unobstructed contact for a complete revolution. Refer to “Using the Auto Dataset® Arms,” page 48.

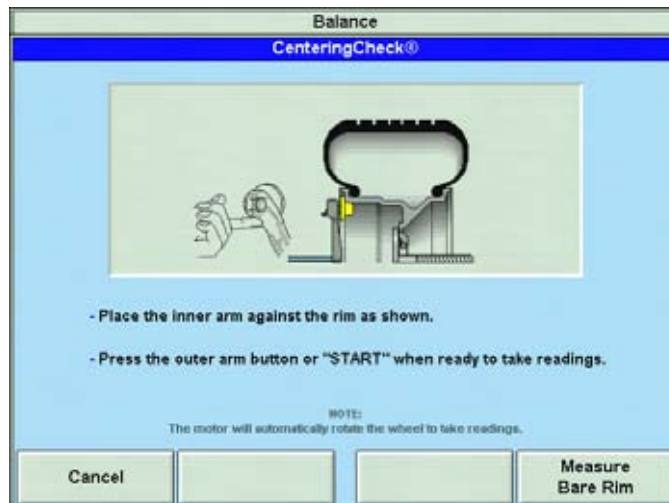

Press the outer Dataset® arm button or “Start” when ready to take readings.

Position the valve stem at 12 o'clock, and then press "Enter Valve Stem."

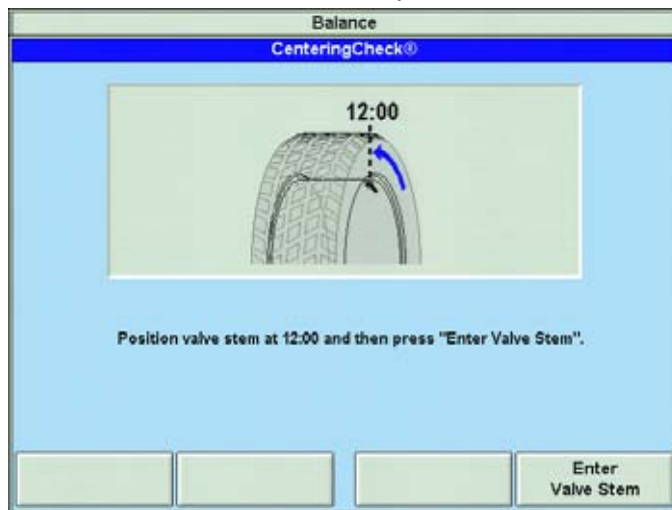

After measuring rim runout, you will be prompted to loosen the wheel and re-clamp at one half turn (approximately 180 degrees) from the current position.

Place the inner arm against the rim as shown.

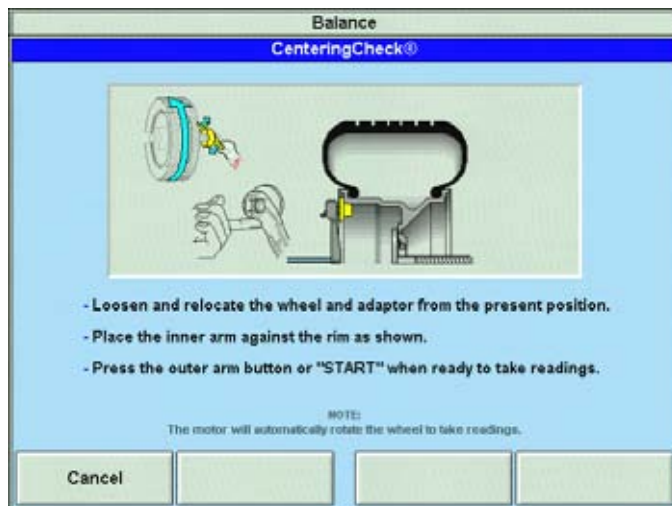

Press the outer arm button or "Start" when ready to take readings.

Once more, position the valve stem at 12 o'clock, and then press "Enter Valve Stem."

If the rim is centered properly, the following screen will appear briefly.



The GSP9700 will then proceed to the “Balance” screen.

If a centering problem is detected, the following screen will appear.

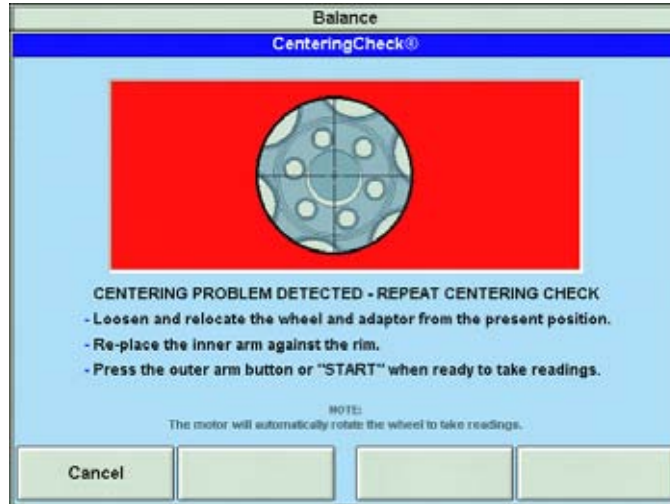

The procedure will repeat the re-centering check up to four times and always compare the previous measurement to the next check. If centering is not achieved after four attempts, the following screen will appear.



Check for:

- Correct mounting cone/adaptor for this wheel design.
- Wheel defect such as a metal burr interfering with the cone/adaptor.
- Dirt or debris interfering with the cone/adaptor.

Follow the on-screen prompts, and then press “Restart Procedure.”

3.3 On-Vehicle Wheel Mounting Methods

Hub Centric

A hub centric wheel is aligned to the hub by the center bore of the wheel. The vehicle weight rests on the hub bore. The clearance between the hub bore and the hub on a hub centric wheel is between 0.003 and 0.004 of an inch. A hub centric wheel is identified by removing the lug nuts (or bolts) and moving the wheel up, down, and side-to-side. If there is little or no movement, the wheel is centered by the hub.

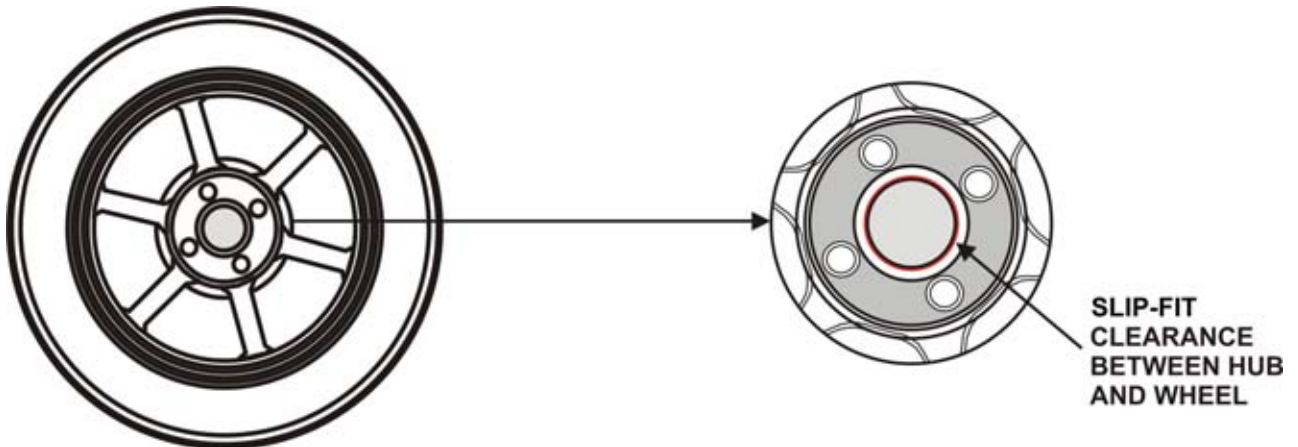

To verify if the wheel is hub centric:

Remove the lug nuts (or bolts) and try to move the wheel up/down and side/side on the hub.

If the wheel has no appreciable movement around or about the centerline of the hub, it should be considered hub centric.

A hub centric wheel will have very little (0.003 – 0.004") clearance or a slip fit to the hub.

Lug Centric

A lug centric wheel is identified by removing the lug nuts (or bolts) and moving the wheel up, down, and side-to-side. If movement around the hub is apparent, the wheel is centered on the vehicle by the lugs or studs of the axle flange.

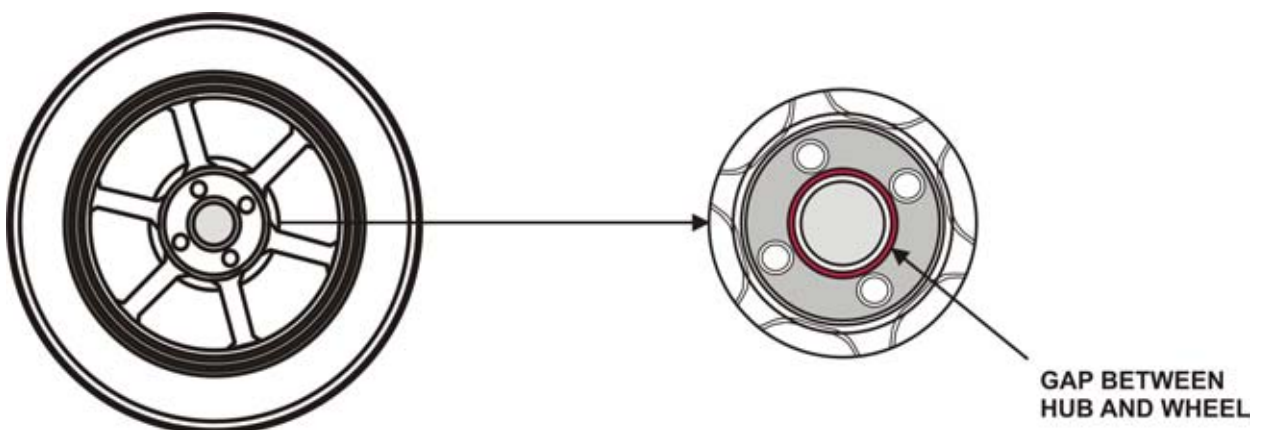

To verify if the wheel is lug centric:

Remove the lug nuts (or bolts) and try to move the wheel up/down and side/side on the hub.

A lug centric wheel will display noticeable movement.

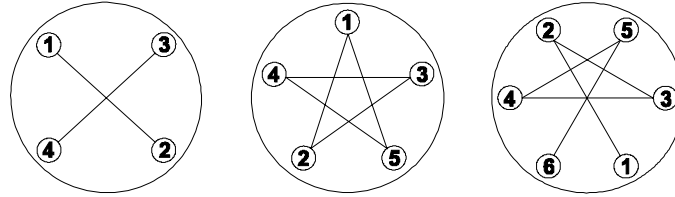

TIP:

When mounting a lug centric wheel to a vehicle, extreme centering care must be taken by ensuring the lug nuts (bolts) are tightened equally, while rotating the wheel.

“Step-torque” star pattern to proper torque specification.

4. Balancing a Wheel

4.1 Balancing Procedures

The GSP series balancer offers two primary ways to balance tires:

1. SmartWeight™ balancing technology
2. Traditional balancing technology

Both of these methods can balance tires dynamically. The main difference is SmartWeight will reduce the amount of corrective weight and possibly limit the number of steps in a basic wheel balancing situation.

SmartWeight™ Balancing Technology

SmartWeight™ balancing technology is a method of reducing forces on a wheel during balancing. SmartWeight is not a procedure. Instead, it measures the forces of side-to-side movement and up-and-down shake and computes weight to reduce these forces. This reduces the amount of weight, reduces time, reduces check spins and chasing weights. SmartWeight saves the shop time and money.

Using SmartWeight™

The SmartWeight enabled balancing display varies slightly from the standard balancing display. The primary difference between the displays is the SmartWeight tire graphs that display the static and couple forces within a tire/wheel assembly.

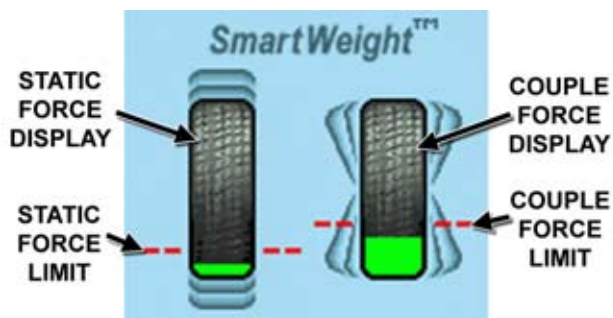

The red-dotted line represents the acceptable amount of force the tire can have that will not result in a ride problem. Any forces below that line will be shown in green. Any forces that are above that level will be shown in red and indicate an excessive amount of force.

The traditional “static” and “dynamic” modes are eliminated. The traditional non-round off mode is eliminated. These modes are no longer necessary with SmartWeight balancing.

Install the tire/wheel assembly as normal. Rim measurements are not required.
Lower the hood and spin.

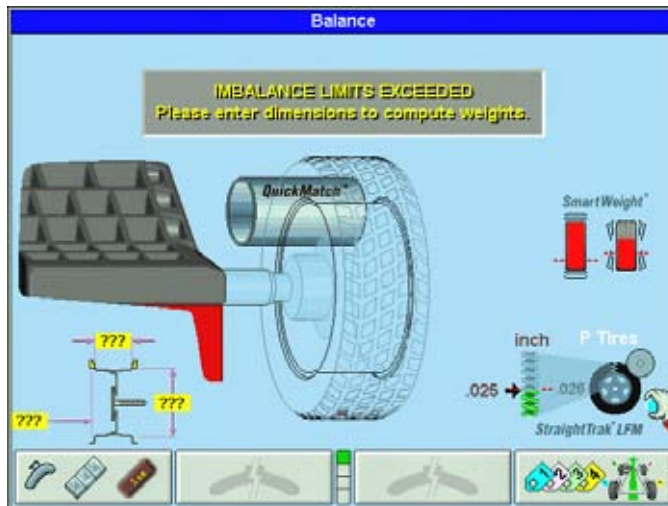

If SmartWeight requires correction weights wheel dimensions will be required.

Enter the dimensions using the dataset arms. The SmartWeight tire graphs will display red for excessive forces and green for acceptable amounts of force. Prior to measurement the tire graphs will display no color.

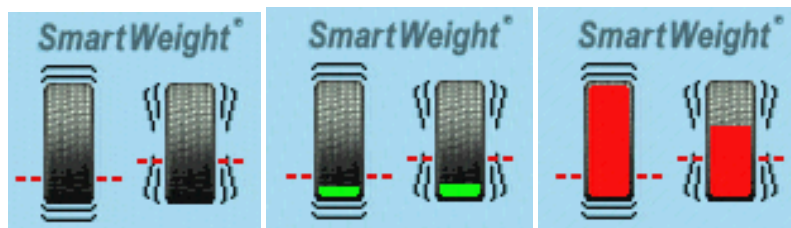

The screen will display the amount and location of corrective weight necessary. Install the weights in the appropriate manner using the correct type of weight and lower the hood to re-spin and check the balance.

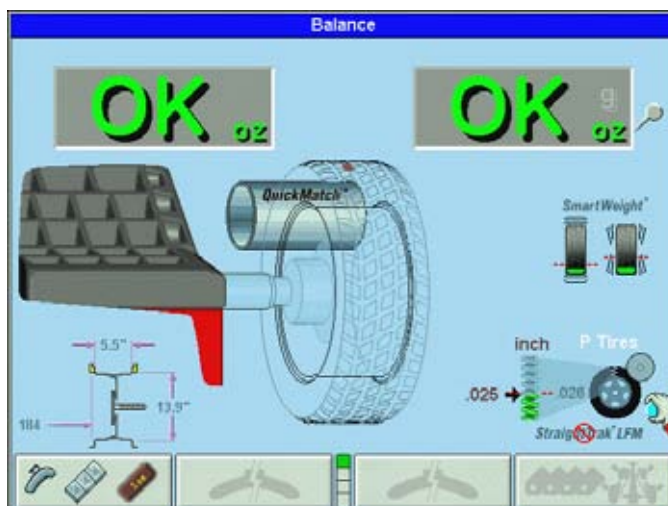

Instead of displaying zeros in the weight display, SmartWeight displays "OK," indicating that the force levels are reduced to within the acceptable tolerances.

Switching from SmartWeight™ to Traditional Dynamic Balancing Modes

At any time, SmartWeight can be switched to standard balancing as long as both standard and SmartWeight modes are enabled in setup.

On units with a control knob, press the knob until SmartWeight is highlighted. Once highlighted, press and hold the knob till the standard balance icons appear. Cycle back the same way.

On units without the control knob select the “Disable SmartWeight” button on the balance screen.

Dynamic Balancing Selection

Dynamic balancing is selected by pointing the indicator to  while rotating the control knob. Dynamic will always display two weight planes.

Dynamic balancing provides a more complete balance than static balancing. Dynamic balancing should be selected whenever possible to minimize vehicle vibration. Refer to “Dynamic Imbalance,” page 16.

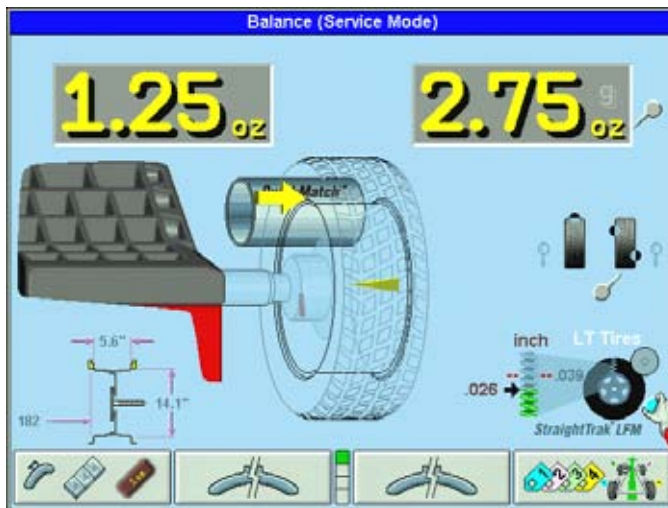

Static Balancing Selection

Static balancing is selected by pointing the indicator to  while using the control knob. Static balancing provides a less desirable balance than dynamic balancing. Dynamic balancing should be selected whenever possible to minimize vehicle vibration. Refer to “Static Balance,” page 15.



Static Balance Mode Reminder for “Dynamic Balance Importance” (Except Patch Balance)

Two reminder pop-up text messages appear on the balance screen dialog box when you first select static mode.

The first screen gives the warning: Avoid STATIC single-plane balancing.

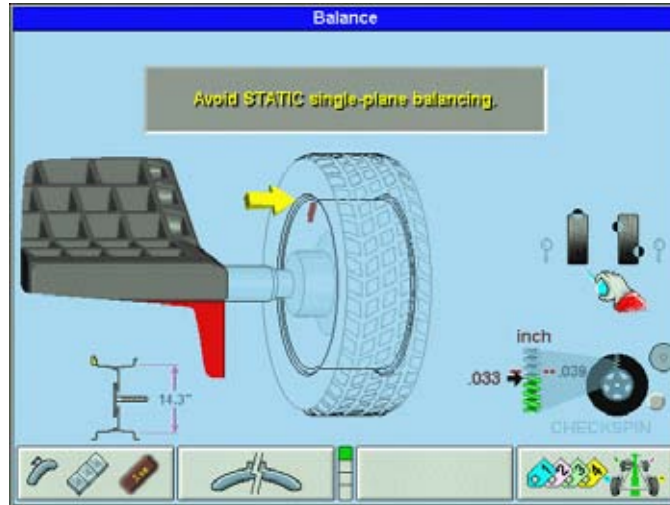

The second screen suggests: DYNAMIC dual-plane balancing recommended (even for hidden weights).

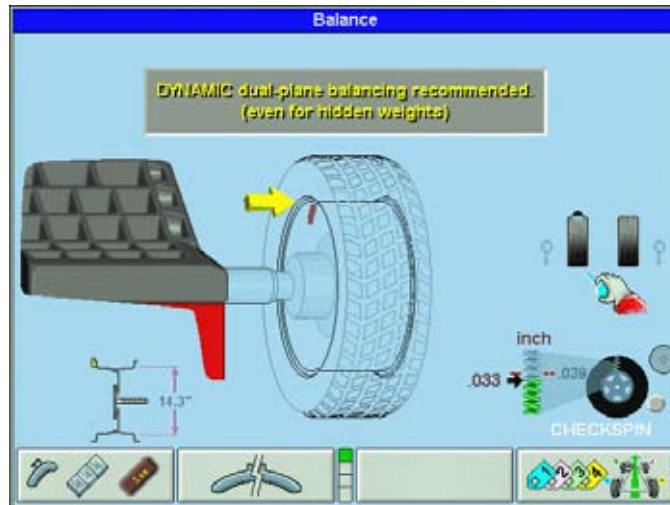

If STATIC is selected, the reminders show up again at the end of the spin, and if in clip-on weight mode, the dynamic weights are shown momentarily, and then the static weight is displayed.

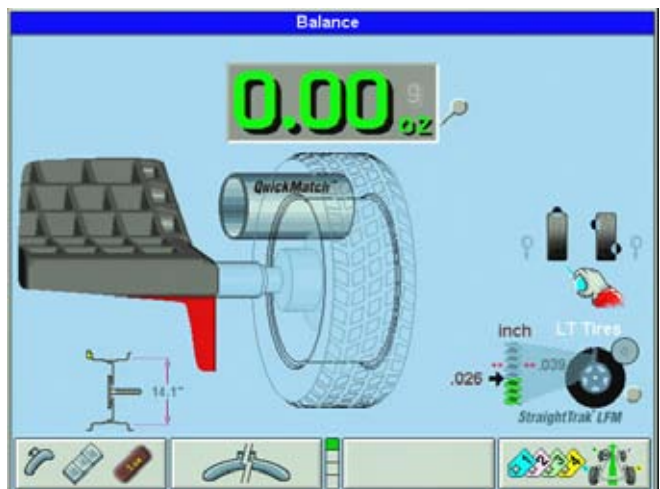
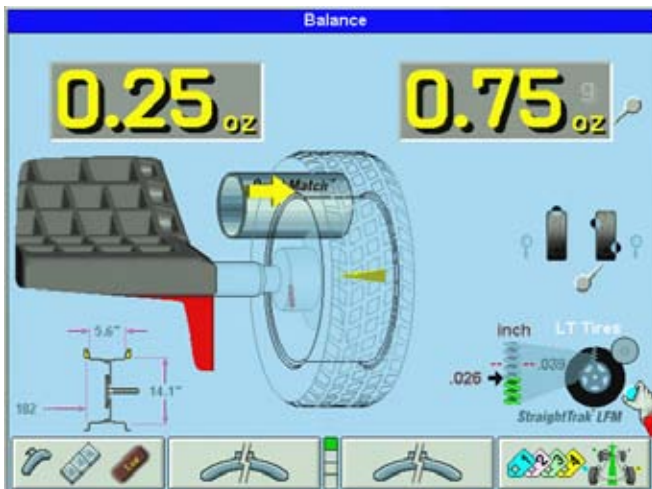

Selecting Weight Types and Placement Modes

Press “” to change the weight types and placement. The GSP9700 offers Standard Balance, Mixed Weights Balance, Adhesive Weights Balance, and Patch Balance® for dynamic and static modes.

With these four selections, a correction weight can be placed at an infinite number of locations, based upon the choice of the operator.

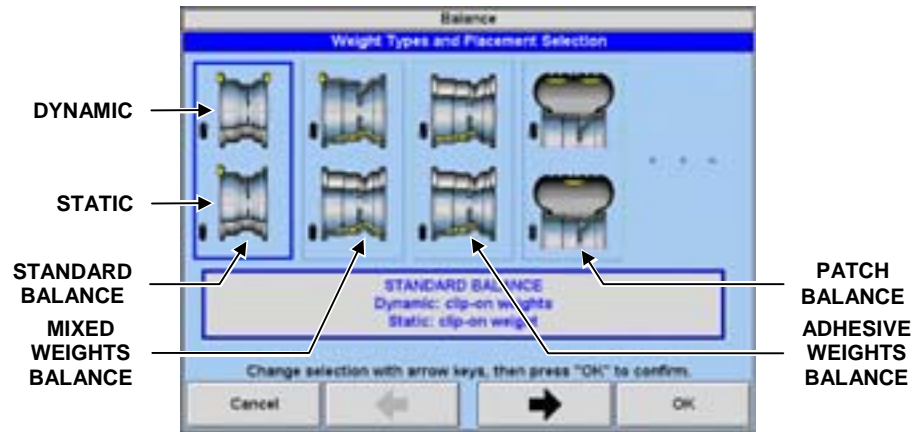

STANDARD BALANCE should be selected when clip-on weights can be used for both rim flanges.

MIXED WEIGHTS BALANCE should be selected when a clip-on weight can be used on the inner rim flange, but not on the outer rim flange. Mixed Weights Balance uses an adhesive weight for the right weight plane instead of a clip-on weight to avoid marring aluminum rims or to hide weights from view.

ADHESIVE WEIGHTS BALANCE should be selected when clip-on weights cannot be used on either rim flange.

PATCH BALANCE should be selected when the tire has a very large imbalance in the tire assembly. The large imbalance can be corrected with Patch Balancing and then the assembly can be fine-tuned with one of the other balancing procedures.

STANDARD Balancing Procedure (Using Clip-On Weights)

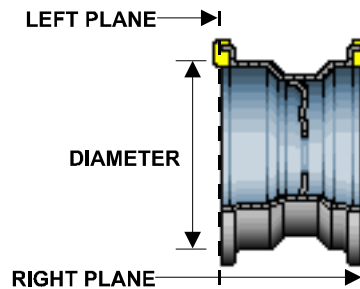

Verify that the wheel is clean and free of debris.

Remove all previous weights.

Mount tire/wheel assembly. Refer to “Mounting the Wheel,” page 23.

Press “.”

Use the softkey arrows to select “STANDARD BALANCE” and press “OK.”

Select either grams or ounces by rotating the control knob and highlighting either “g” or “oz.”

Select “DYNAMIC” by rotating the control knob to highlight “.

 Refer to “Dynamic Balancing Selection,” page 37.

Use both Dataset[®] arms in the **UPWARD** position at the clip-on weight location to measure the distance, diameter, and rim width dimensions. Refer to “Using the Auto Dataset[®] Arms,” page 48.

NOTE: The Dataset[®] Arms should be positioned in the location for weight placement. Refer to “Measuring Dimensions for Standard Clip-on Weight Balancing,” page 49.

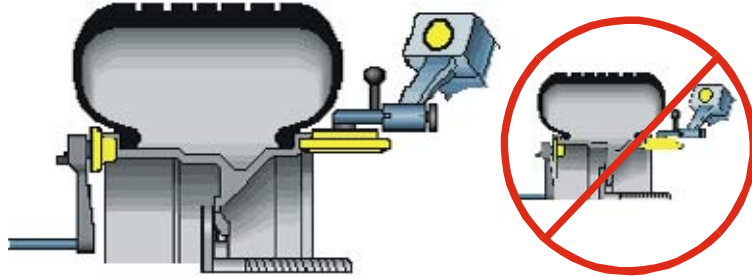

Enter the data by depressing the foot pedal. Release the Dataset[®] arms.

Close safety hood.

Press the green “START” button if “Hood Autostart” is disabled.

After wheel comes to a complete stop, raise the safety hood.

The GSP9700 will find the TDC for the left weight plane if “Servo-Stop” is enabled. “Servo-Stop” will hold the wheel in the TDC position while the weight is applied. The weight amount will be displayed in green.

Attach the weight amount shown on the CRT for the left weight plane to the inner rim of the wheel.

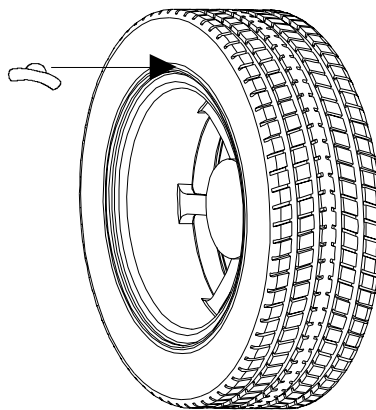

If necessary, use the left “” to split the weight. Refer to “Split Weight[®] Feature,” page 87.

Press the green “START” button with the safety hood in the raised position and the GSP9700 will find the TDC for the right weight plane.

Attach the weight amount shown on the CRT for the right weight plane to the outer rim of the wheel.

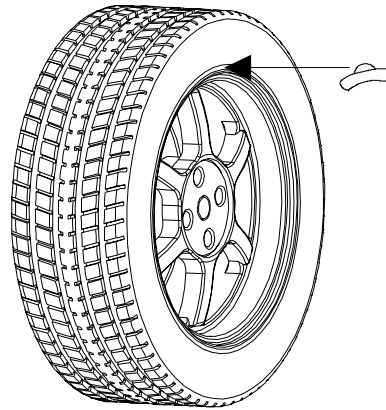

If necessary, use the right “” to split the weight. Refer to “Split Weight[®] Feature,” page 87.

Verify balance condition by spinning again with the load roller disabled. Refer to “Load Roller Operation,” page 60.

Left and right weight plane displays should show “zero.”

STANDARD balancing procedure is complete.

MIXED WEIGHTS Balancing Procedure (Combination of Clip-On & Adhesive Weights)

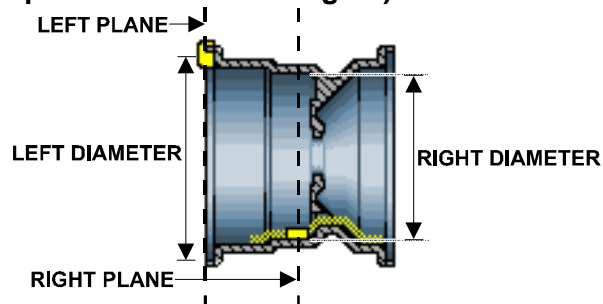

Verify that the wheel is clean and free of debris.

Remove all previous weights.

Mount tire/wheel assembly. Refer to “Mounting the Wheel,” page 23.

Press “.”

Use the arrows to select “MIXED WEIGHTS BALANCE” and press “OK.”

Select either grams or ounces by rotating the control knob and highlighting either “g” or “oz.”

Select “DYNAMIC” by rotating the control knob to highlight “.” Refer to “Dynamic Balancing Selection,” page 37.

Use both Dataset[®] arms in the **UPWARD** position at the clip-on weight location to measure the distance, diameter, and rim width dimensions. Refer to “Using the Auto Dataset[®] Arms,” page 48.

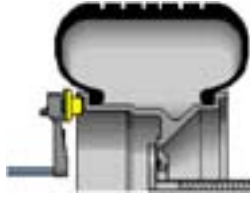

Do **NOT** return the arm to the “home” position.

Using the **DOWNWARD** position, move the inner Dataset[®] arm disk edge to the location for placement of the right edge of the adhesive weight on the right weight plane and enter data by depressing the foot pedal. Refer to “Using the Auto Dataset[®] Arms,” page 48.

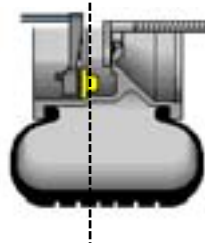

Close safety hood.

Press the green “START” button if “Hood Autostart” is disabled.

After wheel comes to a complete stop, raise safety hood.

The GSP9700 will find the TDC for the left weight plane if “Servo-Stop” is enabled. “Servo-Stop” will hold the wheel in the TDC position while the weight is applied.

Attach the clip-on weight amount shown on the CRT for the left weight plane to the inner rim of the wheel.

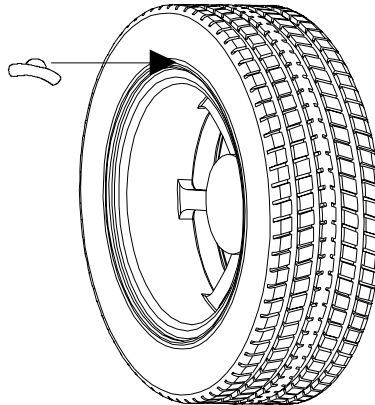

If necessary, use the left “” to split the weight. Refer to “Split Weight[®] Feature,” page 87.

With the servo enabled, attach the adhesive weight using the weight amount shown for the right weight plane on the CRT. Refer to “Servo-Aided Adhesive Weight Placement,” page 51. If servo is not enabled, BDC placement should be used. Refer to “Manual Weight Position Measurement,” page 48.

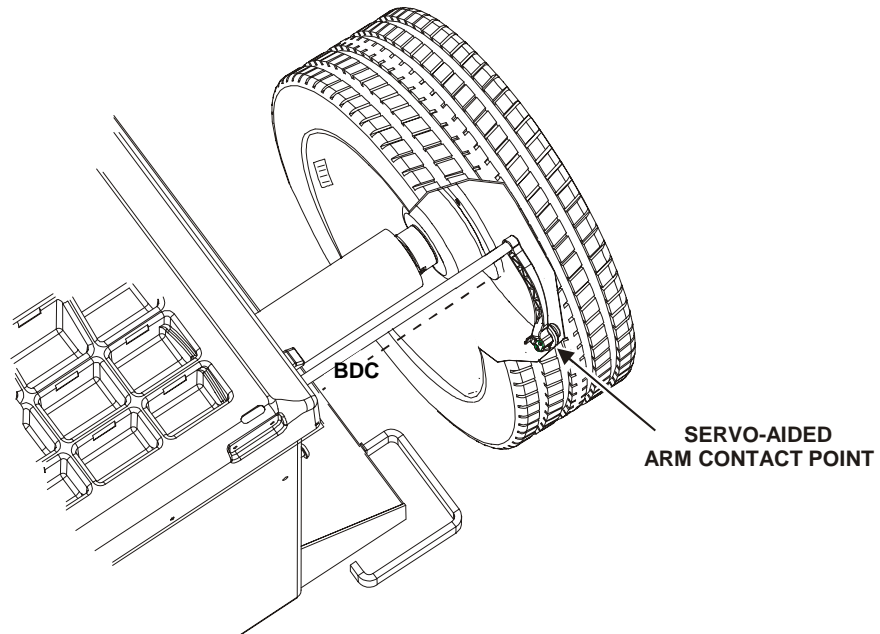

If necessary, use the right “” to split the weight. Refer to “Split Weight® Feature,” page 87.

Verify balance condition by spinning again with the load roller disabled. Refer to “Load Roller Operation,” page 60.

Left and right weight plane displays should show “zero.”

MIXED WEIGHTS balancing procedure is complete.

ADHESIVE WEIGHTS Balancing Procedure (Adhesive Weights Only)

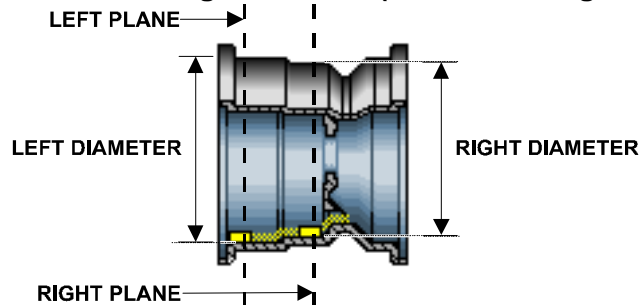

Verify that the wheel is clean and free of debris.

Remove all previous weights.

Mount tire/wheel assembly. Refer to “Mount the Wheel on the Spindle Shaft,” page 23.

Press “.”

Use the arrows to select “ADHESIVE WEIGHTS BALANCE” and press “OK.”

Select either grams or ounces by rotating the control knob and highlighting either “g” or “oz.”

Select “DYNAMIC” by rotating the control knob to highlight “.” Refer to “Dynamic Balancing Selection,” page 37.

Using the **DOWNWARD** position, place the inner Dataset[®] arm disk edge to the outermost location for placement of the right edge of the left adhesive weight and enter the data by depressing the foot pedal. Refer to “Using the Auto Dataset[®] Arms,” page 48.

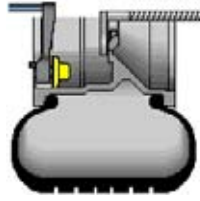

Do **NOT** return the inner Dataset[®] arm to the “home” position.

Using the **DOWNWARD** position, move the inner Dataset[®] arm disk edge to the innermost location for placement of the right edge of the right adhesive weight and enter the data by depressing the foot pedal. Refer to “Using the Auto Dataset[®] Arms,” page 48.





Close safety hood.

Press the green “START” button if “Hood Autostart” is disabled.

After wheel comes to a complete stop, raise the safety hood.

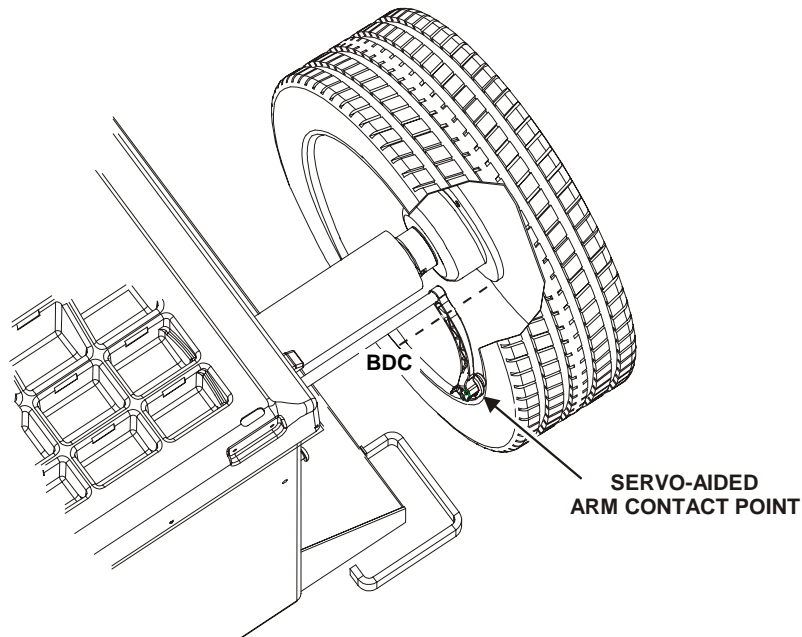
With the servo enabled, attach the adhesive weight for the left weight plane using the weight amount shown on the CRT. Refer to “Servo-Aided Adhesive Weight Placement,” page 51. If servo is not enabled, BDC placement should be used. Refer to “Manual Weight Position Measurement,” page 48.



If necessary, use the left “” to split the weight. Refer to “Split Weight[®] Feature,” page 87.

Return the inner Dataset[®] arm to the home position.

With the servo enabled, attach the adhesive weight for the right weight plane using the weight amount shown on the CRT. Refer to “Servo-Aided Adhesive Weight Placement,” page 51. If servo is not enabled, BDC placement should be used. Refer to “Manual Weight Position Measurement,” page 48.

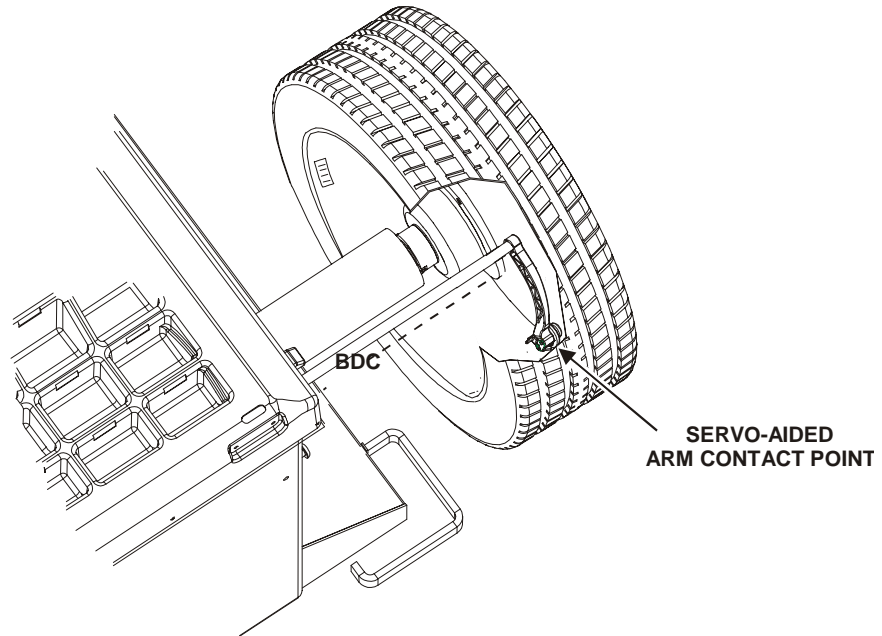

If necessary, use the right “” to split the weight. Refer to “Split Weight® Feature,” page 87.

Verify balance condition by spinning again with the load roller disabled. Refer to “Load Roller Operation,” page 60.

Left and right weight plane displays should show “zero.”

ADHESIVE WEIGHTS balancing procedure is complete.

PATCH BALANCE® Procedure

Weighted balance patches will be placed on the inside of the tire at the edge of the tread area beside the sidewall as shown below:

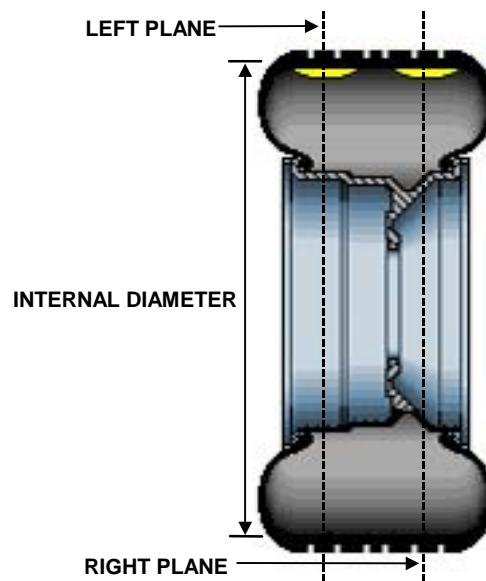

NOTE: Weighted balance patches should be installed only in tread area. Do not install weighted balance patches near sidewall or shoulder of tire.

Verify that the wheel is clean and free of debris.

Remove all previous weights.

Mount tire/wheel assembly. Refer to "Mounting the Wheel," page 23.

Press " ."

Use the arrows to select "PATCH BALANCE" and press "OK."

Select either grams or ounces by rotating the control knob and highlighting either "g" or "oz."

Select "DYNAMIC" by rotating the control knob to highlight " ." Refer to "Dynamic Balancing Selection," page 37.

NOTE:	When measuring large tires that will use balance patches, it may require removal of the outer arm "home position" bumper for ample clearance of the outer Dataset [®] arm. The bumper can be removed by loosening three Phillips head screws and gently pulling the bumper away from the arm.
--------------	--

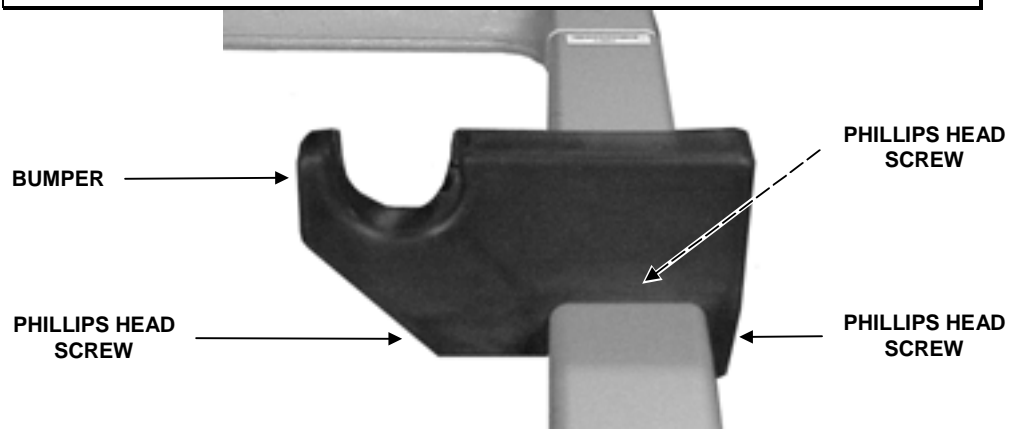

Measure and enter the weight plane distances as follows:

Set two of the widest weighted balance patches available side-by-side on the tread directly above where the left and right weighted patches will be installed inside of the tire. The patches should be positioned as far apart from each other as possible, but should not be placed in the sidewall or shoulder area of the tire.

Mark the tire tread at the center of the patches for future placement reference and remove the patches from the wheel.

Place outer Dataset[®] arm roller directly over the left mark and enter data by depressing the foot pedal.

Place outer Dataset[®] arm roller directly over the right mark and enter data by depressing the foot pedal.

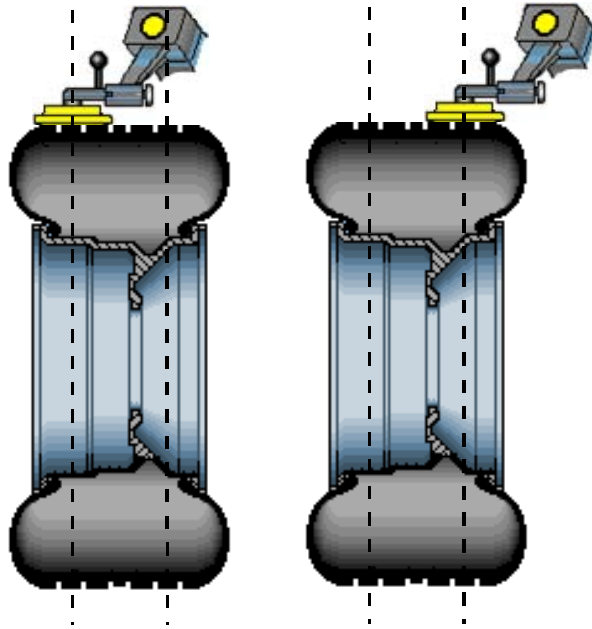

Close safety hood.

Press the green “START” button if “Hood Autostart” is disabled.

After wheel stops spinning, raise the safety hood.

Press the green “START” button with the safety hood in the RAISED position and the GSP9700 will find TDC for the left weight plane. Mark the tire’s inner sidewall for patch placement.

Press the green “START” button with the safety hood in the RAISED position and the GSP9700 will find TDC for the right weight plane. Mark the tire’s outer sidewall for patch placement.

Place an aligning mark on the tire and rim to align them back together after applying the patch weights.

Remove wheel from balancer and dismount tire from rim.

Install left weight plane weighted balance patch(s) at mark(s) as instructed by manufacturer’s instructions.

Install right weight plane weighted balance patch(s) at mark(s) as instructed by manufacturer’s instructions.

Mount tire onto rim, aligning rim and tire marks.

Verify balance condition by spinning again with the load roller disabled. *Refer to “Load Roller Operation,” page 60.*

Finish the patch balancing procedure by returning to the appropriate balance procedure for the type of wheel being balanced. Verify balance condition by spinning again, and attach weights as necessary to correct for residual imbalance.

PATCH balancing procedure is complete.

4.2 Using the Auto Dataset® Arms

Auto Dataset® arms perform two functions:

1. Input weight position measurements for balancing.
2. Input wheel runout measurements for Road Force™ Measurements. Refer to “Road Force™ Measurement,” page 133.

Auto Dataset® is a faster and more accurate method to take rim measurements than traditional methods. Auto Dataset® is used to input rim distance, rim width, and weight plane location automatically. The Dataset® Arms of the GSP9700 are positioned on the weight plane and data is entered by depressing the foot pedal.

Automatic Weight Position Measurement

The Dataset® arms can be used to enter weight position dimensions instantly and accurately. The arms are “triggered” when they are moved away from their home position. When the arms are triggered, a blinking graphic depicting the Dataset® arm on the “Dimension Entry” screen identifies the plane currently being inputted.

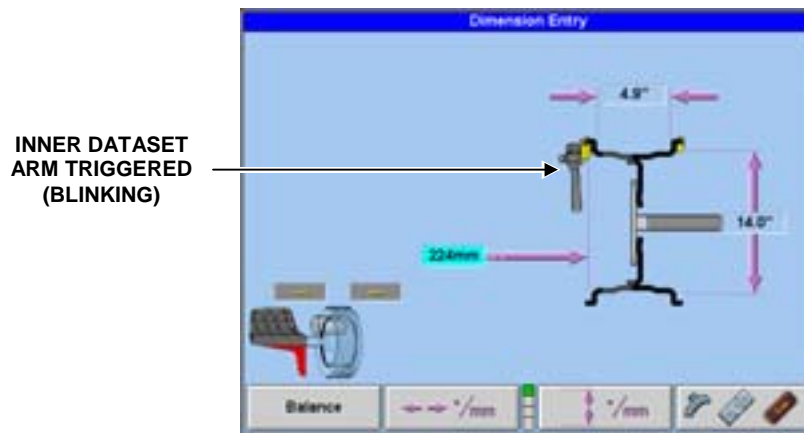

In most cases, the Dataset® Arms are used to input the exact weight position.

The exact weight position is entered by holding the arm(s) stable in the desired location and depressing the foot pedal to enter the dimensional data.

Manual Weight Position Measurement

While on the “Set Dimensions” view of the “Balance” primary screen, the control knob can be used to enter rim dimensions manually.

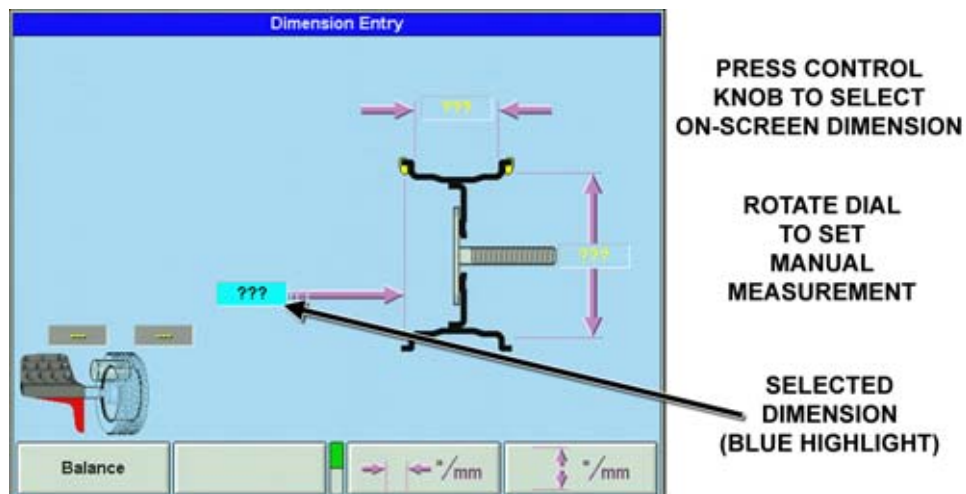

Measuring Dimensions for Standard Clip-on Weight Balancing

To measure rim dimensions for clip-on weights, activate the Standard balancing mode. Pull the inner Dataset[®] arm away from the weight tray and **UPWARD** until it is touching the top of the wheel inner rim lip. Simultaneously pull the outer Dataset[®] arm out and upward until it is touching the top of the wheel outer rim lip. While the Dataset[®] arms are in place, depress the foot pedal to enter the dimensional data. The GSP9700 will beep to confirm data entry.

NOTE: Dataset[®] arms can input dimensions separately if desired.

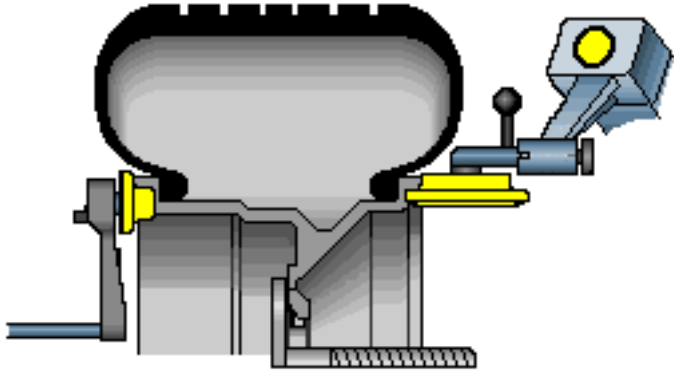

Measuring Dimensions for Mixed Weights (Clip-on/Tape-on) Balance

To measure rim dimensions for the clip-on weight, pull the inner Dataset[®] arm away from the weight tray and **UPWARD** until it is touching the wheel inner rim lip. Depress the foot pedal to enter the dimensional data. The GSP9700 will beep to confirm data entry.

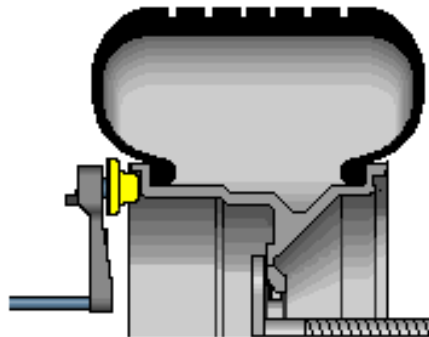

Do **NOT** return the Dataset[®] arm to the home position.

Move the Dataset[®] arm **DOWNWARD** until the roller disk edge is touching the wheel at the right edge of the desired adhesive weight location. Depress the foot pedal to enter the dimensional data. The GSP9700 will beep to confirm data entry.

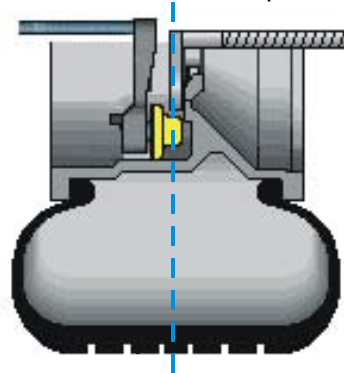

Measuring Dimensions for Adhesive Weights Balancing (Tape-on/Tape-on)

To enter adhesive weight dimensions for the inner plane, pull the inner Dataset[®] arm away from the weight tray and **DOWNWARD**, until the roller disk edge is touching the wheel at the right edge of the desired left weight plane location. Depress the foot pedal to enter the dimensional data. The GSP9700 will beep to confirm data entry.

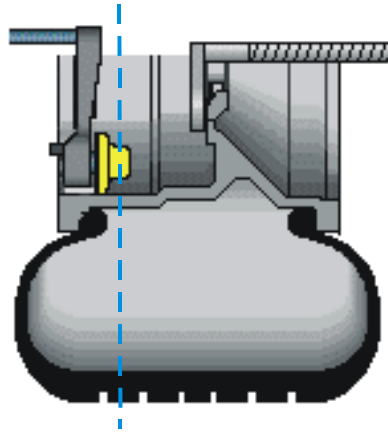

Do **NOT** return Dataset[®] arm to the home position.

Move the Dataset[®] arm at the right weight plane location in the **DOWNWARD** position and depress foot pedal to enter dimensional data. The GSP9700 will beep to confirm data entry.

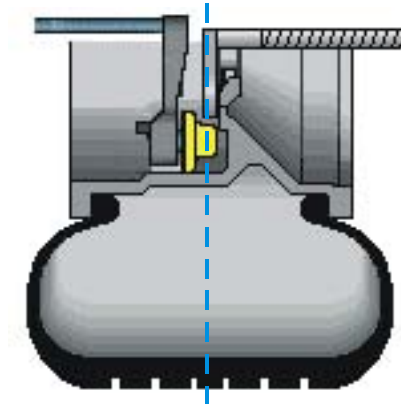

Measuring 20 Inch or Larger Rims

Adjustable Length Inner Dataset® Arm

The inner dataset arm is an extendable two-position arm that can measure data entry and runout for wheels up 30-inch diameter. Retracted arm position measures 10" to 21" wheels. Extended arm position measures 20" to 30" wheels.

Retracted or extended position of inner arm is chosen by the operator from the "Enter Dimensions" screen. This will appear when the inner Auto Dataset® arm is activated.

The extendable inner dataset arm also has the built in stick-on weight holder used to grip adhesive weights for accurate placement on the wheel.



Enabling the dataset arm type to extendable requires that the Service Mode must be accessed and enable in Set Up.

To extend and lock the arm, loosen the locking screw, and slide the arm to the desired length.

If the GSP balancer is not equipped with the extendable two-position arm, an upgrade kit is available through the local Hunter Engineering Company service representative.

Servo-Aided Adhesive Weight Placement

When Servo-Stop is enabled in setup, the inner Dataset® arm can be used to assist in proper placement of adhesive weights. Servo-aided weight placement is a more precise method of weight placement than manual weight placement. The motor will automatically rotate the wheel to the contact point of the arm. This eliminates the need for you to "eyeball" BDC, which often results in weight placement error.

Spin the wheel using Mixed Weights or Adhesive Weights selection.

Shape the weight to a contour similar to the curve of the rim.

Place the required amount of adhesive weight in the weight clip on the inner Dataset[®] arm and remove the peel-off backing from the adhesive weight.

NOTE:

The adhesive weight strip should be centered in the weight clip and the peel-off backing should face away from the inner Dataset[®] arm.



Using dimensional information previously obtained, the on-screen graphic displays and identifies the exact location of the weight plane and the current position of the inner Dataset[®] arm. Pull the inner Dataset[®] arm out from the base until the arm and the weight location are overlapping.



Maintaining that distance, rotate the Dataset[®] arm toward the inner rim surface, and then apply the adhesive weights to the rim by pressing the adhesive weight release tab.



NOTE:

If the servo is off (but is enabled in setup), pressing the "START" button with the hood in the RAISED position will restart the servo for adhesive weight application.

Manual Adhesive Weight Placement

NOTE: Manual weight placement is not as accurate as servo-aided weight placement. Servo-aided weight placement should be used whenever possible.

NOTE: If the servo-aided weight placement is enabled, press the “STOP” button with the hood in the **RAISED** position to disable.

To manually place adhesive weights on the rim after spinning, the inner Dataset[®] arm should be used to verify the previously inputted distance.

Rotate the wheel until the location arrow of the desired weight plane is green.

Lift the inner Dataset[®] arm from home position. The “real-time” number displayed between the two numbers that represent previously inputted data displays the current reading of the inner Dataset[®] arm. The arm should be placed in the downward position on the rim until the real-time number matches the previously inputted data.

NOTE: Lifting the inner Dataset[®] arm will trigger the balancer for dimension input. Do **NOT** step on the foot pedal or new dimensions will be entered.

The weight should be placed at **BDC** at that distance.

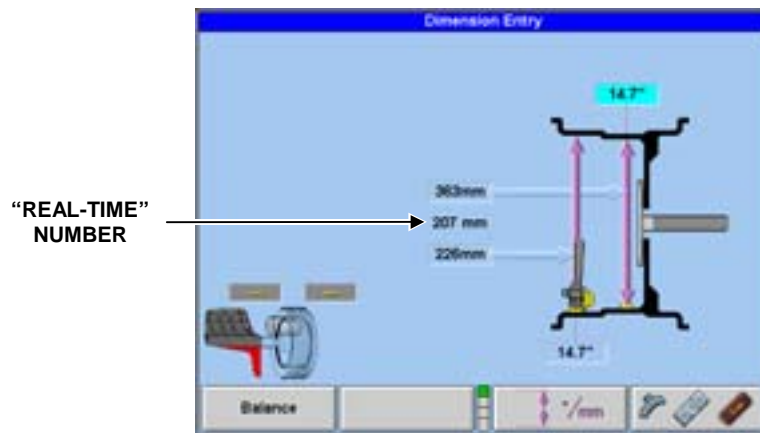

Rim Runout Measurements

Rim runout can be measured externally with the tire mounted to the rim bead seats, or the bare rim can be measured separately for more precise measurements. If the assembly does not have a flat faced rim, take the runout measurement. *Refer to “Rim Runout External Measurement (Tire and Wheel Assembly),” below. If the assembly is flat faced, and you are prompted by the GSP9700 to take runout data, or to verify the runout data already taken with the tire in place, take the runout measurement as described in “Rim Runout Measurement (Bare Rim),” page 56.*

Bare rim measurement is a more accurate method of measuring rim runout. Bare rim measurements can also be used to audit bare rims prior to the installation of a tire.

Runout can be viewed by selecting “Show Runout & Road Force” from the “Balance” primary screen.

Single Arm Rim Runout External Measurement (Tire and Wheel Assembly)

The inner Dataset Arm can be used alone externally to measure rim runout of the inboard bead seat. This method is not as accurate as two position measurement, but it is faster for QuickMatch™ predictions.

Dual Arm Rim Runout External Measurement (Tire and Wheel Assembly)

If the GSP9700 determines that there is a problem with the wheel assembly, it will prompt you to measure rim runout. The “Measure Rim Runout” popup screen can be selected from the “Balance” primary screen, or by pressing the outer arm button once. To measure rim runout with the tire on the rim, remove all clip-on weights from the rim and place the inner and outer Dataset® arm on the rim as shown below:

NOTE:	Note the location of the Dataset® arms on the rim. The location for rim runout measurement is NOT the same as the location for inputting rim dimensions for weight location.
-------	---

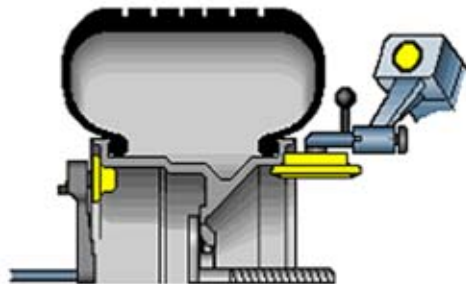

**CORRECT POSITION FOR
MEASURING RIM RUNOUT**

**(INCORRECT POSITION FOR
CLIP WEIGHT POSITION ENTRY)**



**INCORRECT POSITION FOR
MEASURING RIM RUNOUT**

**(CORRECT POSITION FOR
CLIP-WEIGHT POSITION ENTRY)**

When Dataset[®] arms are in place, press the outer arm button. The motor will slowly rotate the wheel to measure runout. While the wheel is in motion, **gently apply upward and inward fingertip pressure on both Dataset[®] arms as shown below:**

⚠ CAUTION: Take care when placing hands to measure rim runout that no part of your hands or body interfere with parts in motion.

NOTE: Do not grasp the Dataset[®] arms. Use fingertip pressure only.

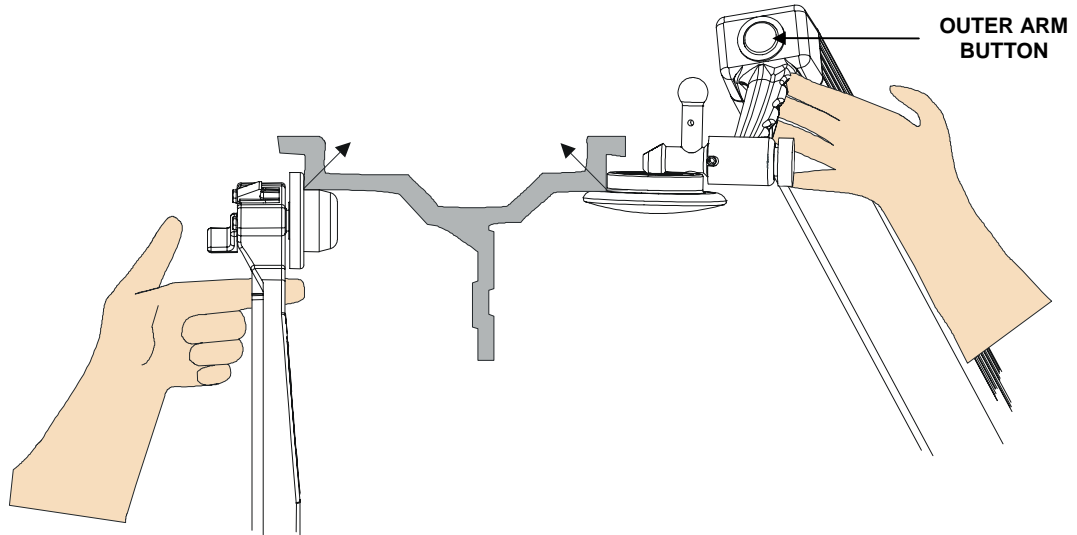

The runout data will automatically be displayed when the operation is complete. The inner and outer rim runout first harmonics will be shown as amounts in the upper left-hand corner of the screen. Radial high spots of runout will be shown as blue indicators on the rim. Lateral high spots will be shown as orange indicators on the rim when "Show Lateral High Spots" is selected. The average of the inner and outer radial first harmonic high spots are taken to locate the average radial first harmonic rim low spot (matching mark). Refer to "Harmonics & T.I.R. Data/Plots," page 98.

Rim Runout Measurement (Bare Rim)

To measure bare rim runout, remove the tire from the rim. Mount the bare rim on the GSP9700. Select “Measure Rim Runout” from the “Balance” primary screen. Select “Measure Bare Rim.” Loosen the outer Dataset[®] arm locking screw by turning it counter-clockwise. Pull out and rotate the rim runout ball on the outer Dataset[®] arm to the downward position. Secure the locking screw. Place the outer Dataset[®] arm ball against the left bead seat lip as shown below:

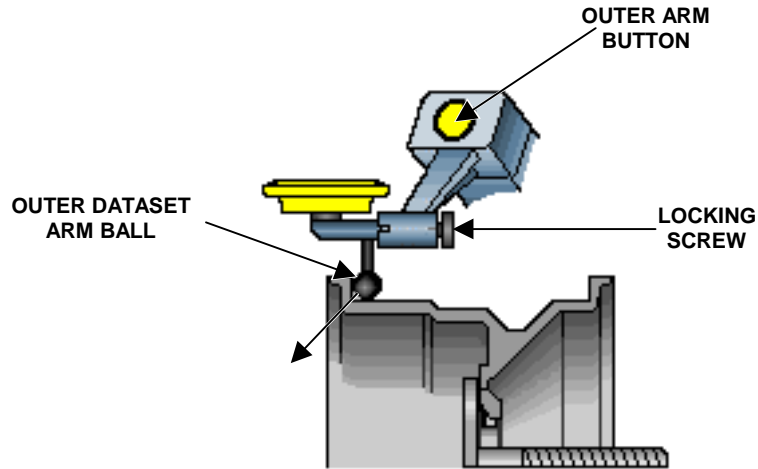

When outer Dataset[®] arm ball is in place, press the outer arm button. The motor will slowly rotate the rim to measure runout. While the wheel is in motion, gently apply a downward and outward pressure on the outer Dataset[®] arm ball.

When the screen prompts, place the outer Dataset[®] arm ball against the right bead seat lip as shown below:

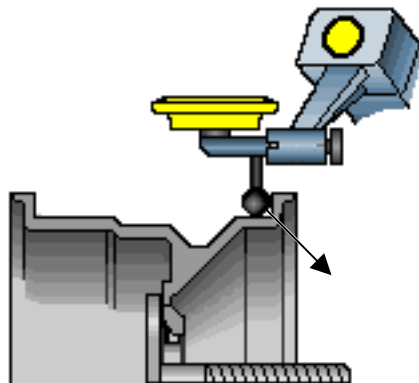

When the Dataset[®] arm ball is in place, press the outer arm button. The motor will slowly rotate the rim to measure runout. While the wheel is in motion, gently apply a downward and outward pressure on the Dataset[®] arm ball.

If the data will be used in ForceMatching™, scribe a mark with chalk or a marker to realign the rim to the hub/shaft assembly after the tire is mounted. After mounting the tire and re-spinning, the runout data of the bare rim may be recalled by pressing “Recall Last Rim Data” from the “Runout & Road Force” popup screen. *Refer to “ForceMatching™ Using Previous Bare Rim Measurement,” page 63.*

4.3 Primary and Popup Screens

Primary Screen Selection

Primary screens are selected from either of the two softkey rows of the “Logo” screen of the GSP9700 by pressing the menu shift key.

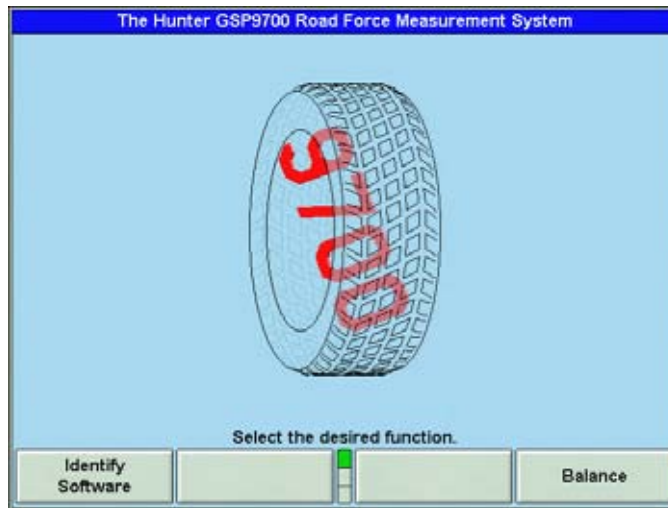

When a primary screen is showing, there is only a single “title bar” across the top of the display. For example, see the following “Balancer Set Up” primary screen.

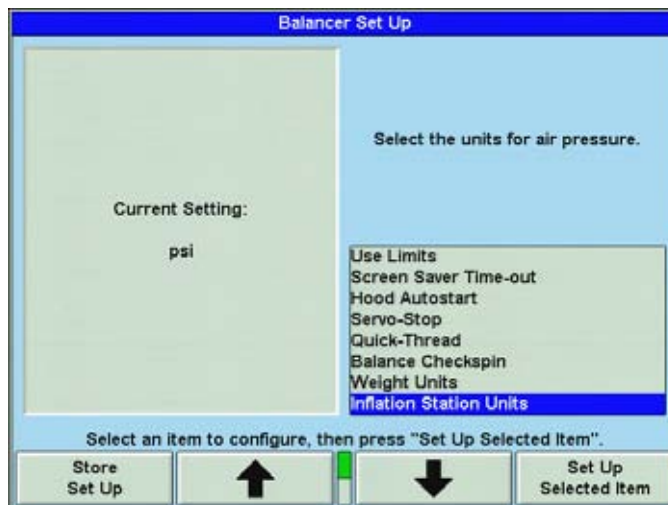

Within each primary screen, there are popup screens that can be selected. A popup screen pops up over the current screen to perform that operation, and the softkeys change to those needed to support the operation.

For example, the “CenteringCheck®” popup screen pops up over the “Balance” primary screen. The softkeys change from the primary screen to support the “CenteringCheck®” operation.

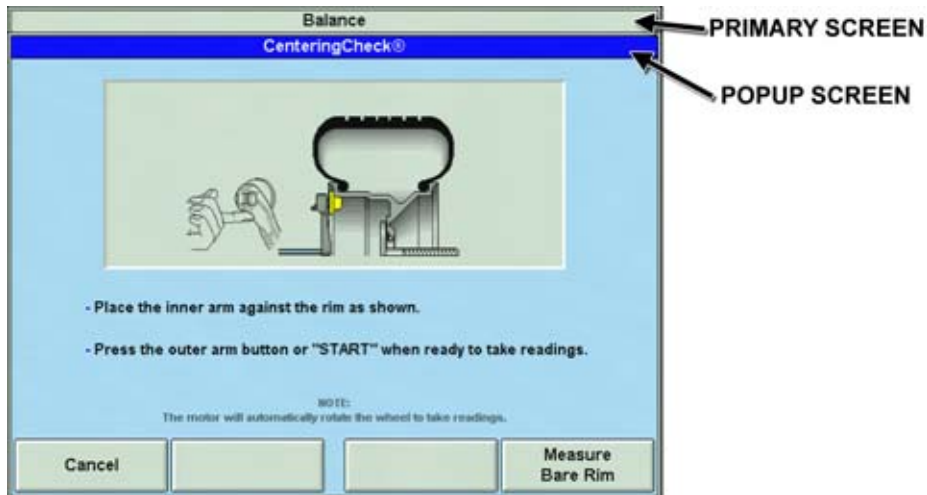

When the operation is complete or has been cancelled/exited, the popup screen reveals the primary screen from which it appeared.

Notice two very important aspects of this scheme:

The popup screen does not completely “hide” the screen over which it pops up. It leaves the title bar of the primary screen exposed while the title bar of the current selection is highlighted.

The popup screen has a softkey menu that supports only the operations required by that screen. This greatly simplifies the menus of the primary screens and makes it easier to control the operation of the popup screens.

Balance Primary Screen

The “Balance” primary screen has a choice of two related views. They are:

Set Dimensions

Apply Weights

By pressing “Set Dimensions” or “Apply Weights,” the primary screen toggles views of the current operation. The first row menu keys will change to those needed for the current view, while the second and third row menu keys remain the same.

The “Apply Weights” view is the spinning operation view of the balancer. The Split Weight® softkeys are available in this view on the first row menu. The on-screen switches change the gram/ounce selection, the dynamic/static (blind/round) selection, and the load roller enable/disable selection.

The “Set Dimensions” view is displayed in reduced size in the lower left-hand corner. It can be enlarged by pressing “Set Dimensions” or will automatically enlarge if a Dataset® Arm is moved from home position and triggered to take rim data.

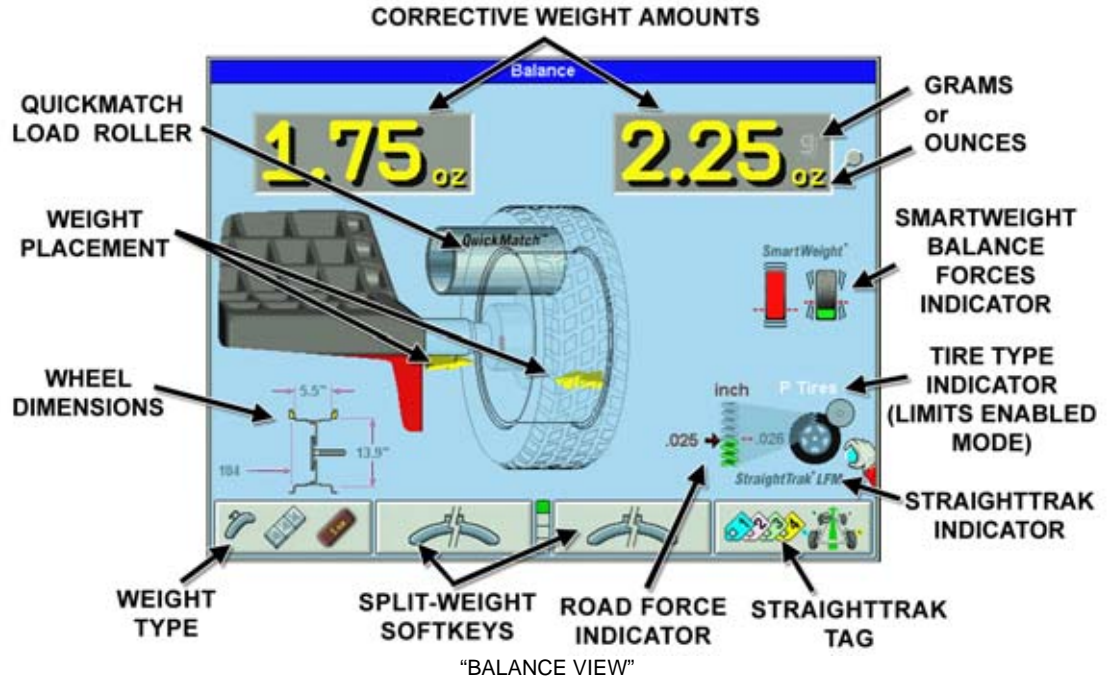

The “Set Dimensions” view enlarges the dimensional diagram of the wheel assembly. The inch/millimeter selection softkeys are available in this view on the first row menu. The control knob(s) can be used to manually enter the rim dimensions. The “Apply Weights” view is displayed in reduced size in the lower left-hand corner. It can be enlarged by pressing “Apply Weights,” or will automatically enlarge if the wheel is spun or if both Dataset® arms are in the home position after one or both arms have been triggered to take rim data.

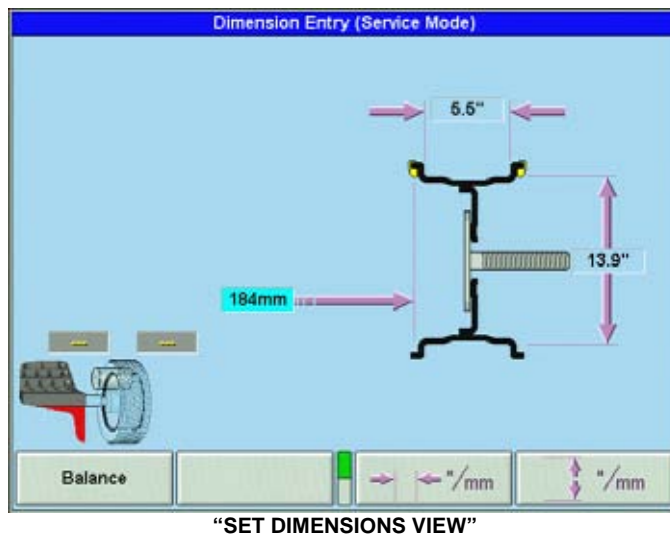

4.4 Load Roller

Load Roller Operation

The load roller runs parallel to the tire and applies a perpendicular load on the assembly to take Road Force™ Measurements. It is capable of applying up to 1400 pounds of force. The amount of force placed on the tire is dependent upon the tire's diameter and stiffness. The load roller will not overload the tire.

NOTE: It is important that the air pressure of the tire is set to specifications prior to the Road Force™ Measurement. Incorrect tire pressure will affect the results. If the GSP9700 is equipped with the Inflation Station feature, the tire can be easily set to the specified air pressure. Refer to "Inflation Station," page 81.

The load roller can be enabled and disabled by turning the control knob. When the load roller is enabled, the CRT will display the load roller on the screen as shown below.

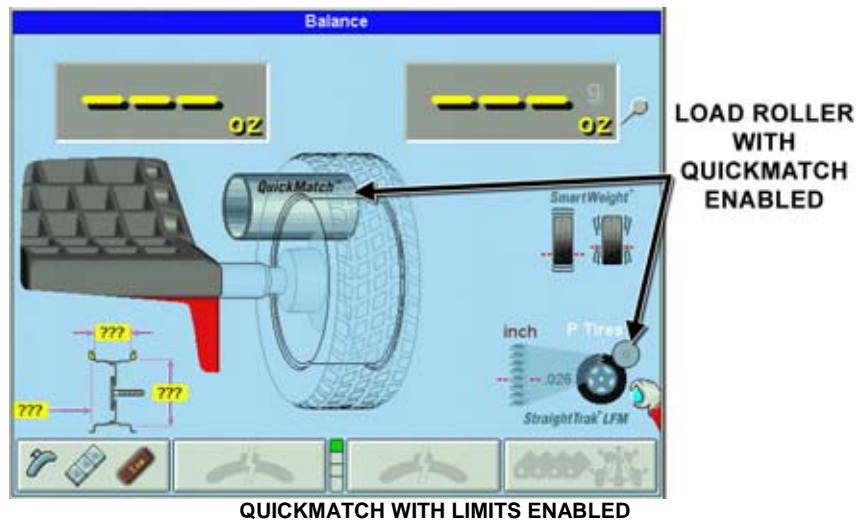

Road Force with Limits Enabled: when the load roller selection is made, "LT Tires," "P-SUV Tires," or "P Tires" road force specifications can be highlighted by slowly turning the knob to the appropriate selection. Changing the "LT Tires," "P-SUV Tires," or "P Tires" selection will change the limit specifications for road force and rim runout. Refer to "Setting Up the Runout & Road Force Units," page 109.

NOTE: The load roller cannot be enabled in "Bare Rim Spin" mode.

When the load roller is disabled, only a balance spin will be performed. This can be useful for a balance check spin after weights have been applied.

Load roller data can be viewed by selecting "Show Runout & Road Force" from the "Balance" primary screen.

4.5 ForceMatching™

ForceMatching™ is a method of aligning the stiffest spot of the radial tire road force first harmonic (once-per-revolution component) with the average low point of the radial rim runout first harmonic to decrease vibration in the wheel assembly. Refer to *“Theory of Operation,”* page 131. This type of match mounting has been done with expensive equipment by the tire/wheel manufacturers and OEMs for years to provide the smooth ride associated with a new vehicle. This is the first time equipment is available to provide “ForceMatching™” at a service level. When the GSP9700 performs a spin with the load roller enabled, it measures the road force of the wheel assembly. Refer to *“Road Force™ Measurement,”* page 133.

NOTE: It is important that the air pressure of the tire is set to specifications prior to the Road Force™ Measurement. Incorrect tire pressure will affect the results. If the GSP9700 is equipped with the Inflation Station feature, the tire can be easily set to the specified air pressure before and after ForceMatching. Refer to *“Inflation Station,”* page 81.

After measuring the assembly, if it detects a Road Force™ Measurement beyond user specified limits, it prompts the operator to measure rim runout. Refer to *“Rim Runout Measurements,”* page 54.

After measuring rim runout, the results will be shown on the “Current Runout & Road Force” popup screen.

NOTE: ForceMatching™ results and benefits are not computed until rim runout is measured.

If limits are enabled in the setup mode then the “Current Runout & Road Force” screen “Diagnosis” box will display a message informing you whether ForceMatching will be beneficial. The diagnosis and basis for calculating conclusions is always based on the limits chosen by the operator from the Balance Screen and Setup Mode.

If the wheel assembly can be corrected by ForceMatching™, the diagnosis box will display “ForceMatching procedure will bring assembly within limits” and the components will be listed as “Pass,” “Marginal,” or “Limit Exceeded.” If non-first harmonic component limits are exceeded, the “Diagnosis Explanation” popup screen will automatically appear. Refer to *“Diagnosis Explanation Screen,”* page 95.

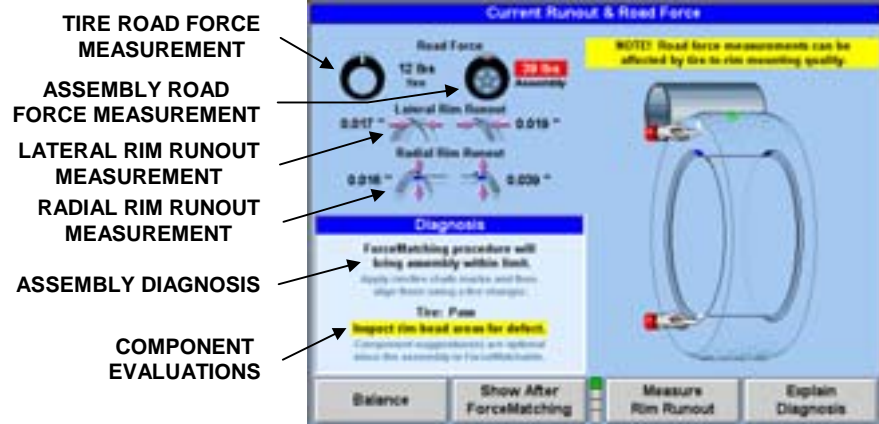

The “Show After ForceMatching” key may be selected to view the estimated road force that will remain after the ForceMatching procedure has been completed.

ForceMatching™ Procedures

To correct road force by ForceMatching™:

Rotate the tire road force high spot on the wheel to TDC, or with the hood in the raised position and the servo enabled, press "START." Mark the tire with a piece of chalk or a marker at TDC. If desired, mark the tire with the ForceMatch Code. Refer to "Using ForceMatch Codes Feature," page 64.

NOTE: When the wheel is rotated to TDC, the chalk will appear green on the console display and the tire ForceMatch Code will appear in the tire tread.

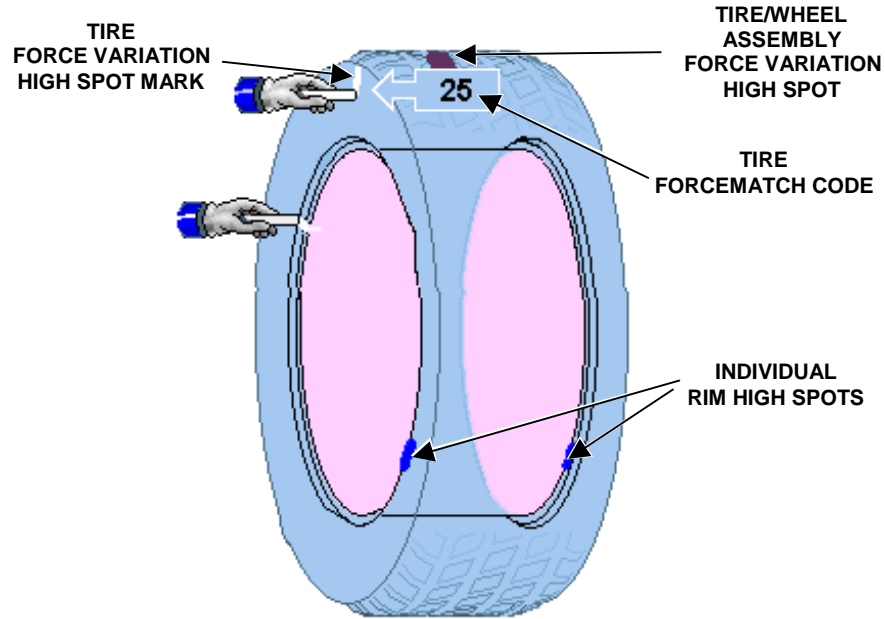

Rotate the rim low spot on the wheel to TDC, or with the hood in the raised position and the servo enabled, press "START." Mark the rim with a piece of chalk or a marker at TDC. If desired, mark the rim with the ForceMatch Code. Refer to "Using ForceMatch Codes Feature," page 64.

NOTE: When the wheel is rotated to TDC, the chalk will appear green on the console display and the rim ForceMatch Code will appear between the rim lips.

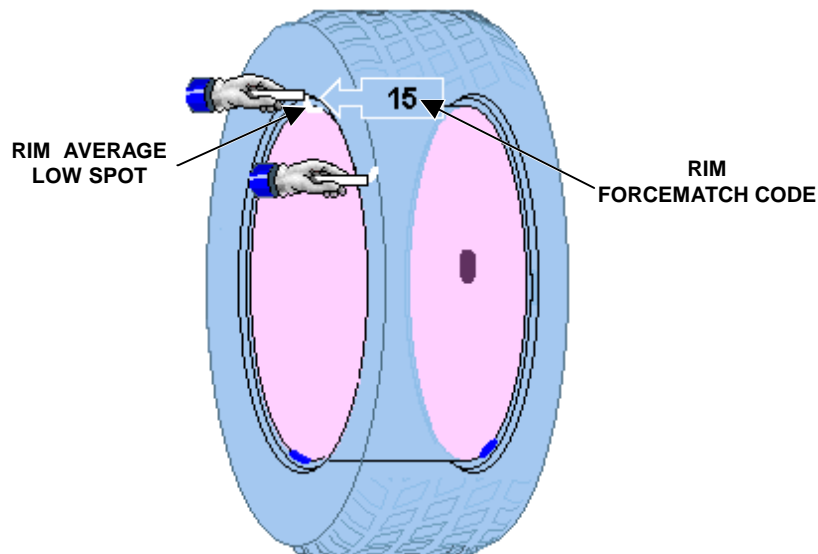

Use a tire changer and align the tire and rim marks to one another. *Refer to the operation instructions for the tire changer in your shop.*

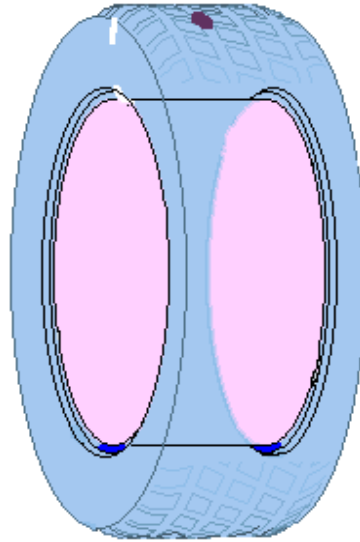

NOTE: If the wheel assembly can be corrected by ForceMatching™, the results can be viewed prior to removing the assembly from the balancer by selecting “Show After ForceMatching” from the “Balance” primary screen.

If the wheel assembly cannot be corrected by ForceMatching™, the diagnosis box will display “ForceMatching will not bring assembly within limits” and may suggest component replacement. *Refer to “Diagnosis Explanation Screen,” page 95.*

ForceMatching™ is complete.

ForceMatching™ Using Previous Bare Rim Measurement

If bare rim measurements (*refer to “Rim Runout Measurement (Bare Rim),” page 56*) have been taken and will be used for ForceMatching™ procedures, it will be necessary to scribe two aligning marks with a marker or chalk on the hub/shaft assembly and the rim. This will allow you to align the rim and hub/shaft assembly back together after mounting the tire on the rim. After spinning with the tire mounted and the load roller enabled, press “Apply Last Rim Data” from “Balance” primary screen. This will recall the bare rim runout data from the previous rim measurement.

ForceMatching™ Using Previous Road Force™ Measurement

This procedure should be used if a bare rim measurement will be taken for rim runout data after the Road Force™ Measurement has been obtained, such as when the rim runout data cannot be measured from the outside surface of the rim and the Road Force™ Measurement has exceeded the limit.

With chalk or a marker, draw two aligning marks on the hub/shaft assembly and the rim.

Mark the tire at the location of the valve stem and label the line “VS.”

Remove the assembly from the balancer.

Remove the tire from the rim and remount the bare rim onto the balancer, being careful to realign the rim and hub/shaft assembly marks.

Take the bare rim measurement. *Refer to “Rim Runout Measurement (Bare Rim),” page 56.*

Press “Apply Last Tire Data” to recall the previous Road Force™ Measurement.

Mark the rim at the high spot of tire road force and label the mark “FV.”

Mark the rim at the low spot of rim runout and label the mark “RR.”

Lay the tire down on the floor.

Remove the rim from the balancer and set it on top of the tire with the valve stem (“VS”) mark on the tire aligned to the valve stem.

With the valve stem and valve stem (“VS”) mark aligned, transfer the road force (“FV”) mark from the rim to the tire and label it “FV.”

Mount the tire on the rim with the road force (“FV”) mark on the tire and rim runout (“RR”) mark on the rim aligned.

Using ForceMatch Codes Feature

When a tire or rim matching mark is placed at TDC, the corresponding ForceMatch Code is displayed. The code numbers can be recorded on the tire/wheel for optimal matching procedures. Matching a tire and rim with similar match code numbers may decrease the first harmonic vibration substantially.

Matching Tire/Wheel Sets:

A set of tires and rims may be matched to each other for optimum vibration reduction. The tire and rim with the highest match code should be paired, then tire and rim with the second highest match code should be paired, continuing the pattern for the entire set.

Matching Inventory:

Shops with inventory can label existing stock with ForceMatch Codes and optimally match assemblies prior to sale to reduce ForceMatching™ mounting time, reduce tire vibration, and increase customer satisfaction. The tire and rim match code can be labeled and the high/low spot marked and inventoried for later use. Tires and rims can then be matched to each other for optimal ride performance. A marginal rim or tire can be put into stock and later be matched to a rim/tire with a similar ForceMatch Code for a minimal first harmonic vibration.

Dial Indicator Gauges Feature

The “Show Dial Indicators” key may be selected from the “Current Runout & Road Force” screen to display on-screen dial indicator gauges. Each gauge displays the runout (actual arm movement) encountered at that location. This data is also displayed as the total indicated reading (T.I.R.) data on the runout plot screens. Refer to “*Harmonics & T.I.R. Data/Plots*,” page 98. If there is green only showing in the span of the gauge, T.I.R. runout is acceptable. If green and yellow appear on the span of the gauge, T.I.R. runout is marginal. If red appears on the span of the gauge, T.I.R. runout has been exceeded and may prompt an informative statement to appear in the Diagnosis Box concerning the exceeded limit. The dial indicator located directly above the tire tread is the loaded runout of the assembly as taken by the load roller. As the wheel assembly is rotated on the spindle, the dial indicator gauges will change to display current information for each dial indicator gauge position.

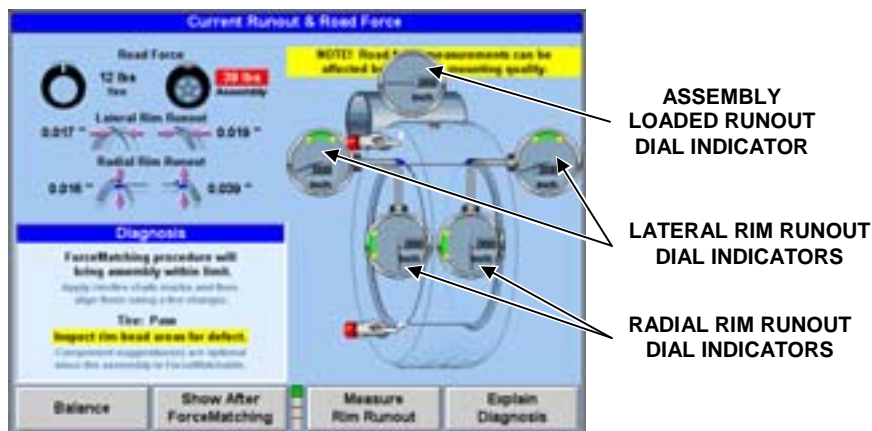

“Hide Dial Indicators” can be selected to remove the dial indicator gauges from the screen. Rim runout and road force will still be graphically depicted on the screen.

Lateral/Radial Rim High Spot Indicators Feature

The “Show Lateral High Spot(s)” and “Show Radial High Spot(s)” softkeys are available to select a graphic depiction of the exact radial (blue indicators) or lateral (orange indicators) first harmonic runout high spot locations. The high spots indicated are the high spots of the first harmonic, NOT the T.I.R. runout high spots. The lateral/radial high spots correspond to the lateral and radial first harmonic rim runout amounts on the left side of “Current Runout & Road Force” screen. Located 180 degrees from the rim matching mark is a green indicator that will appear between the rim lips to identify the rim average 1st harmonic high spot.

Details/Diagnosis Explanation Key

“Show Details” can be selected to view detailed data about measurements taken and the limits for each measurement.

When limits that are not first harmonic are exceeded, the “Show Details” key will be replaced with an “Explain Diagnosis” key which can be selected to view information on exceeded limits for the rim or tire. Refer to “*Diagnosis Explanation Screen*,” page 95.

Encountering ForceMatching™ Prediction Errors

Below are some reasons why the GSP9700 may not match or quantify the value of the tire or the assembly.

- **Incorrect Mechanical Wheel Mounting on the Shaft:**
This can be caused from worn or damaged adaptors, rust, or debris on the wheel, shaft, hub, adaptors, or a cone contacting a wheel on an irregular surface. Verify proper mounting by performing a centering check.
- **External Rim Measurement vs. Actual Bead Seat Measurement:**
There is a high correlation between external and internal measurement, however the operator must consider each wheel design individually. Some cast or closed-faced wheels cannot be accurately measured externally. The tire must be removed for accurate bead seat runout measurements.
- **Air Pressure Readings Before and After Matching Differ:**
The air pressure should remain constant between each measurement. Always inflate tires to the recommended pressure specified by the vehicle manufacturer.
- **Incorrect Tire Bead Seating Procedures:**
Tire technology is always changing. Today’s vehicles require the tire to be designed to tightly adhere to the wheel, preventing slippage between the two components. As a result, incorrect tire bead seating procedures are becoming more of an issue in solving vibration complaints. In many cases, a wheel will display high non-uniformity values because of increased tire bead interference, wheel design, or improper bead seating procedures. If the tire is re-loosened from the wheel and properly lubricated and remounted, the level of non-uniformity may decrease dramatically. On sensitive vehicles, sometimes there is benefit to slightly over-inflating the tire, deflating the air, and then re-inflating to optimize bead seating.
- **Insufficient Use of Tire Mounting Lube During Mounting:**
“Lube is Good!” Proper lubrication on the tire bead **and** rim areas including bead seat, hump, balcony, and drop center are vital in achieving proper seating of the tire bead to the wheel assembly. Aggressive acceleration or braking should be avoided for the first 500 miles to prevent tire to wheel slippage.
- **Rim Safety Hump Design ‘Hangs Up’ Tire Bead During Bead Seating:**
Some types of wheels use a square safety hump that may further inhibit uniform tire bead seating. This further underscores the importance of proper lubrication and bead seating procedures.
- **Temporary Flat Spotting:**
Flat spotting may occur when the tire is in one position for an extended period of time, such as a parked vehicle, improper storage of the tire, and temperature extremes. Measurements for force and balance will stabilize as soon as the tire is driven for a few miles. This important issue can also affect traditional wheel balancing procedures.
- **Excessive Lateral Runout of Tire and/or Rim:**
A tire or wheel with high lateral readings may affect the predicted results of radial force after ForceMatching.

Do's and Don'ts of Road Force™ Measurement

- Tires may need to be warmed up to remove temporary flat spots prior to testing.
- Verify the wheel is centered.
- Use the approved adaptors for GSP9700.
- Use wing nut provided and it must be tight (do not use quick take up wing nuts).
- Tire inflation pressure must meet vehicle manufacturers specifications.
- The tire/wheel assembly must be free of debris.
- Bare rim runout measurements are required if the wheel design does not permit external measurement of the outer bead seat area.
- Use realistic Road Force™ measurement limits for the vehicle being tested.
- If chosen limits have been exceeded, never use Road Force™ measurement alone to replace a tire unless specified by the manufacturer.

4.6 QuickMatch™ Tire and Wheel Mounting

QuickMatch™ tire and wheel mounting procedure is a method of aligning the high spot of the radial loaded runout first harmonic (once-per-revolution component) with the average low spot of the radial rim runout first harmonic to decrease vibration in the wheel assembly. Refer to “Theory of Operation,” page 131.

QuickMatch™ is available as a softkey selection if enabled from the setup menu. This method of match-mounting does not calculate Road Force, however, displays runout measurements of the tire and wheel with faster cycle time compared to road force measurement. QuickMatch™ with runout is faster than Road Force, however, is not recommended as the best choice for diagnostic use and vibration problem solving.

After measuring the assemblies loaded runout, it prompts the operator “QuickMatch? Yes or No”. Refer to “Rim Runout Measurements,” page 54. If the operator chooses “Yes”, the GSP9700 will then prompt the operator to measure rim runout.

After measuring rim runout, the results will be shown on the “Current Runout” pop-up screen.

NOTE:	QuickMatch™ tire and wheel mounting procedure results and benefits are not computed until rim runout is measured.
-------	---

The “Current Runout” screen will display a message informing you if QuickMatching™ will be beneficial.

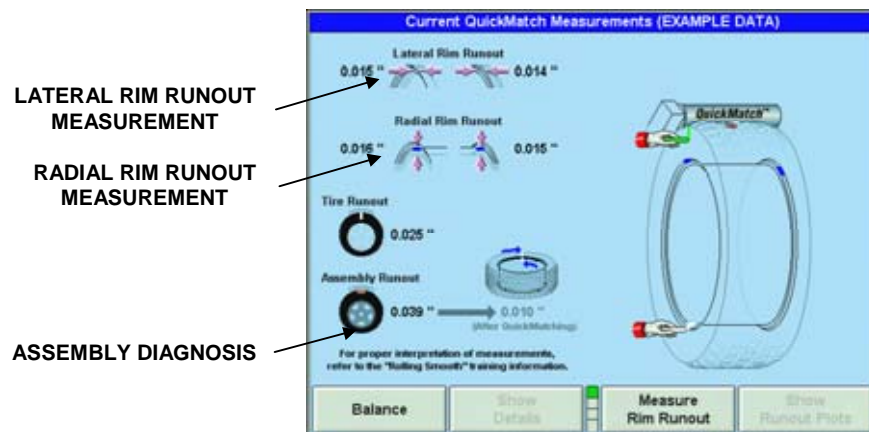

QuickMatch™ Procedures

To correct loaded runout by QuickMatch™:

Rotate the tire loaded runout high spot on the wheel to TDC, or with the hood in the raised position and the servo enabled, press “START.” Mark the tire with a piece of chalk or a marker at TDC.

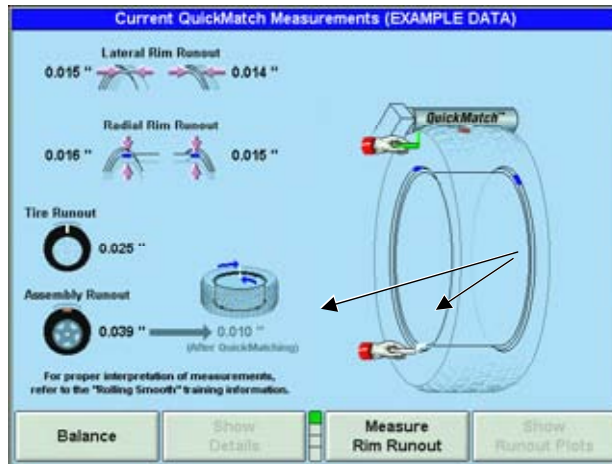

Rotate the rim low spot on the wheel to TDC, or with the hood in the raised position and the servo enabled, press “START.” Mark the rim with a piece of chalk or a marker at TDC.

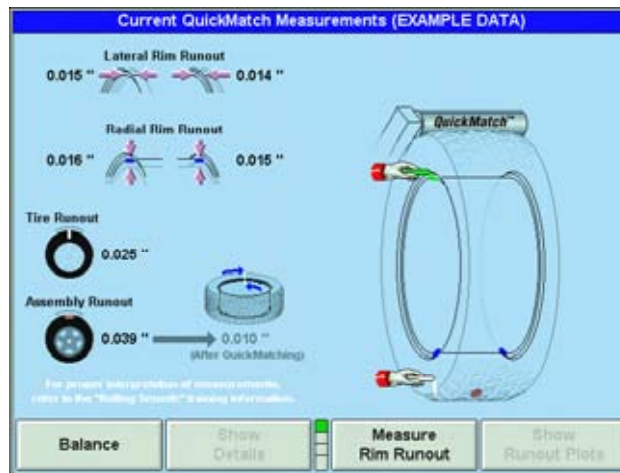

Use a tire changer and align the tire and rim marks to one another. Refer to the operation instructions for the tire changer in your shop.

NOTE: If the wheel assembly can be corrected by QuickMatch™, the results can be viewed prior to removing the assembly from the balancer by viewing the “Current QuickMatch Measurements” primary screen.

QuickMatch™ is complete.

QuickMatch™ Using Previous Bare Rim Measurement

If bare rim measurements (refer to “*Rim Runout Measurement (Bare Rim)*,” page 56) have been taken and will be used for QuickMatch™ procedures, it will be necessary to scribe two aligning marks with a marker or chalk on the hub/shaft assembly and the rim. This will allow you to align the rim and hub/shaft assembly back together after mounting the tire on the rim. After spinning with the tire mounted and the load roller enabled, press “Apply Last Rim Data” from “Current QuickMatch Measurements” primary screen. This will recall the bare rim runout data from the previous rim measurement.

QuickMatch™ Using Previous Loaded Runout Measurement

- This procedure should be used if a bare rim measurement will be taken for rim runout data after the Loaded Runout Measurement has been obtained, such as when the rim runout data cannot be measured from the outside surface of the rim.
- With chalk or a marker, draw two aligning marks on the hub/shaft assembly and the rim.
- Mark the tire at the location of the valve stem and label the line “VS.”
- Remove the assembly from the balancer.
- Remove the tire from the rim and remount the bare rim onto the balancer, being careful to realign the rim and hub/shaft assembly marks.
- Take the bare rim measurement. Refer to “*Rim Runout Measurement (Bare Rim)*,” page 56.
- Press “Apply Last Tire Data” to recall the previous Loaded runout Measurement.
- Mark the rim at the high spot of tire loaded runout and label the mark “TR.”
- Mark the rim at the low spot of rim runout and label the mark “RR.”
- Lay the tire down on the floor.
- Remove the rim from the balancer and set it on top of the tire with the valve stem (“VS”) mark on the tire aligned to the valve stem.
- With the valve stem and valve stem (“VS”) mark aligned, transfer the loaded runout (“TR”) mark from the rim to the tire and label it “TR.”
- Mount the tire on the rim with the loaded runout (“TR”) mark on the tire and rim runout (“RR”) mark on the rim aligned.

Dial Indicator Gauges Feature

The “Show Dial Indicators” key may be selected from the “Current QuickMatch Measurements” screen to display on-screen dial indicator gauges. Each gauge displays the runout (actual arm movement) encountered at that location. This data is also displayed as the total indicated reading (T.I.R.) data on the runout plot screens. Refer to “*Harmonics & T.I.R. Data/Plots*,” page 98. If there is green only showing in the span of the gauge, T.I.R. runout is acceptable. If green and yellow appear on the span of the gauge, T.I.R. runout is marginal. If red appears on the span of the gauge, T.I.R. runout has been exceeded. The dial indicator located directly above the tire tread is the loaded runout of the assembly as taken by the load roller.

As the wheel assembly is rotated on the spindle, the dial indicator gauges will change to display current information for each dial indicator gauge position.

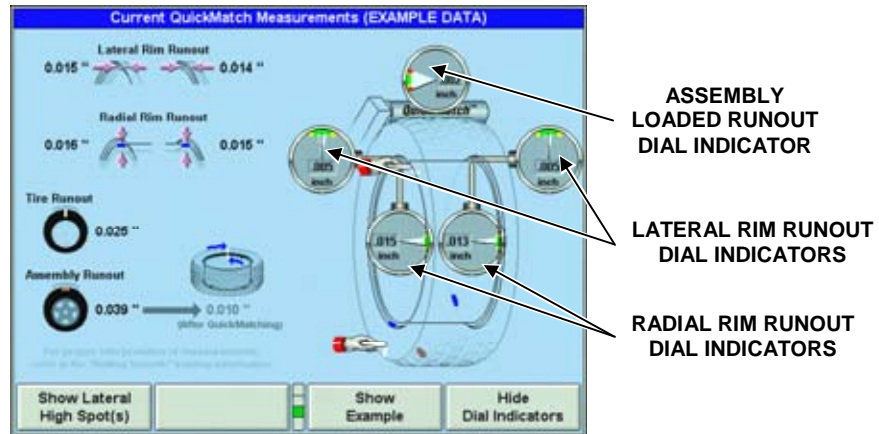

“Hide Dial Indicators” can be selected to remove the dial indicator gauges from the screen. Rim runout and loaded runout will still be graphically depicted on the screen.

Lateral/Radial Rim High Spot Indicators Feature

The “Show Lateral High Spot(s)” and “Show Radial High Spot(s)” softkeys are available to select a graphic depiction of the exact radial (blue indicators) or lateral (orange indicators) first harmonic runout high spot locations. The high spots indicated are the high spots of the first harmonic, NOT the T.I.R. runout high spots. The lateral/radial high spots correspond to the lateral and radial first harmonic rim runout amounts on the left side of “Current QuickMatch Measurements” screen. Located 180 degrees from the rim matching mark is a green indicator that will appear between the rim lips to identify the rim average 1st harmonic high spot.

Encountering ForceMatching™ or QuickMatching™ Prediction Errors

Below are some reasons why the GSP9700 may not match or quantify the value of the tire or the assembly.

- Incorrect Mechanical Wheel Mounting on the Shaft:**
This can be caused from worn or damaged adaptors, rust, or debris on the wheel, shaft, hub, adaptors, or a cone contacting a wheel on an irregular surface. Verify proper mounting by performing a centering check.
- External Rim Measurement vs. Actual Bead Seat Measurement:**
There is a high correlation between external and internal measurement, however the operator must consider each wheel design individually. Some cast or closed-faced wheels cannot be accurately measured externally. The tire must be removed for accurate bead seat runout measurements.
- Incorrect Tire Bead Seating Procedures:**
Tire technology is always changing. Today’s vehicles require the tire to be designed to tightly adhere to the wheel, preventing slippage between the two components. As a result, incorrect tire bead seating procedures are becoming more of an issue in solving vibration complaints. In many cases, a wheel will display high non-uniformity values because of increased tire bead interference, wheel design, or improper bead seating procedures. If the tire is re-loosened from the wheel and properly lubricated and remounted, the level of non-uniformity may decrease dramatically. On sensitive vehicles, sometimes there is benefit to slightly over-inflating the tire, deflating the air, and then re-inflating to optimize bead seating.
- Insufficient Use of Tire Mounting Lube During Mounting:**
“Lube is Good!” Proper lubrication on the tire bead **and** rim areas including bead seat, hump, balcony, and drop center are vital in achieving proper seating of the tire bead to the wheel assembly. Aggressive acceleration or braking should be avoided for the first 500 miles to prevent tire to wheel slippage.

- **Rim Safety Hump Design ‘Hangs Up’ Tire Bead During Bead Seating:**
Some types of wheels use a square safety hump that may further inhibit uniform tire bead seating. This further underscores the importance of proper lubrication and bead seating procedures.
- **Temporary Flat Spotting:**
Flat spotting may occur when the tire is in one position for an extended period of time, such as a parked vehicle, improper storage of the tire, and temperature extremes. Measurements for force and balance will stabilize as soon as the tire is driven for a few miles. This important issue can also affect traditional wheel balancing procedures.
- **Excessive Lateral Runout of Tire and/or Rim:**
A tire or wheel with high lateral readings may affect the predicted results.

Do’s and Don’ts of Loaded Runout Measurement

- Some tires may need to be warmed up to remove temporary flat spots prior to testing.
- Verify the wheel is centered before measurements are taken.
- Use wing nut provided and it must be tight.
- Tire inflation pressure must meet vehicle manufacturers specifications.
- The tire/wheel assembly must be free of debris.
- Bare rim runout measurements are required if the wheel design does not permit external measurement of the outer bead seat area.
- Use realistic Runout measurement values for the vehicle being tested.
- If chosen values have been exceeded, never use Runout measurement alone to warranty a tire unless specified by the manufacturer.

4.7 StraightTrak[®] LFM (Lateral Force Measurement)

StraightTrak[®] is an optional feature that corrects vehicle pull problems by suggesting that the tires be placed at specific locations on the vehicle. If the vehicle being tested has unidirectional tires, or different size tires front and rear, not all of the displayed options will be valid.

Tire-related pulls are caused by lateral forces in the tires. Lateral force is the amount of left or right pull force created as the tire rolls along the road. This condition may cause a vehicle to steer away from straight ahead. These forces are primarily created by conicity and cannot be detected during standard balancing or alignment service.

The StraightTrak[®] LFM feature measures lateral tire force during the GSP9700's "Road Force Measurement" test. The GSP9700 then applies this lateral force information to a set of tires, providing the operator with multiple placement choices about the vehicle. Tires are tagged and positioned on the vehicle to provide the least amount of vehicle pull and obtain the best straight ahead steering stability. Pull or drift caused by the lateral forces can be systematically minimized, offset or eliminated.

Performing a StraightTrak® LFM Procedure:

Mount the tire/wheel assembly centered on the shaft of the GSP9700. Use care to make sure the wing nut is well tightened.

Choose the appropriate balancing procedure for the particular type of rim construction.

Check the tire pressure. Inflation Station will automatically inflate or deflate the tire to the preset air pressure. When the tire pressure is correct, the tire graphic on the screen will turn green.

If tire pressure is not checked before load roller application, an auto prompt for the Inflation Station will appear.

NOTE:	Lateral force varies significantly with tire inflation pressure. For accurate results, it is important that the inflation pressure for each tire is set to the correct value.
--------------	---

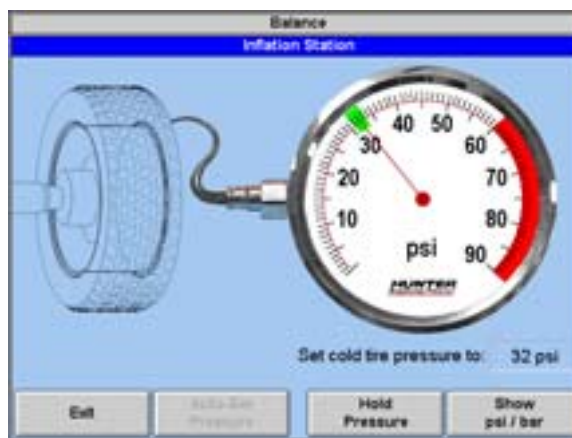

Enter rim dimensions by using the inner and outer Dataset arms.

If using a balancing procedure other than the standard clip-on/clip-on weight, StraightTrak® Lateral Force Measurement will prompt the operator to measure the inner and outer rim locations to establish wheel offset to the roller. This is a baseline measurement necessary for the StraightTrak® Lateral Force Measurement. Use the inner and outer Dataset arms to measure the rim locations.

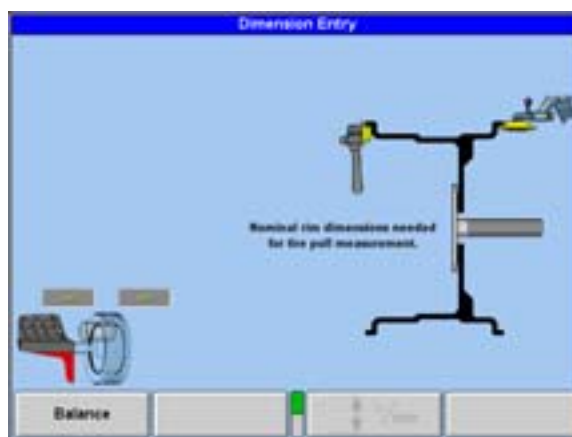

Close safety hood.

Press the green "START" button if "Hood Autostart" is disabled.

After the radial measurements are taken, a lateral force sensor measures forces exerted in the lateral (axial) direction. The drive system then reverses direction and again measures the forces exerted in the lateral (axial) direction. The display provides the operator with RoadForce and imbalance measurements.

NOTE: Lateral force is not shown for individual tires, but is stored in memory for use on the Vehicle Plan View screen.

After wheel comes to a complete stop, raise the safety hood.

Perform any tire/wheel Force Matching required to reduce radial RoadForce disturbances.

Apply the appropriate balance weight.

Press the  "Tire Tags" softkey to number the tire/wheel assembly. The screen will default to tag 1. Press "OK" to accept tag 1 and continue.

Attach the corresponding identifying tag to the valve stem of the tire/wheel assembly or number the assembly with a tire crayon.

Mount the second tire/wheel assembly on the GSP9700 and perform ForceMatching (if needed) and balancing.

Press  "Tire Tags" softkey to number the second tire/wheel assembly. The screen will default to tag 2. Press "OK" to accept tag 2. *Refer to "Changing Tag Numbers," page 75.*

After tagging the second tire/wheel assembly, the vehicle plan view will appear. *Refer to "Vehicle Plan View," page 74.*

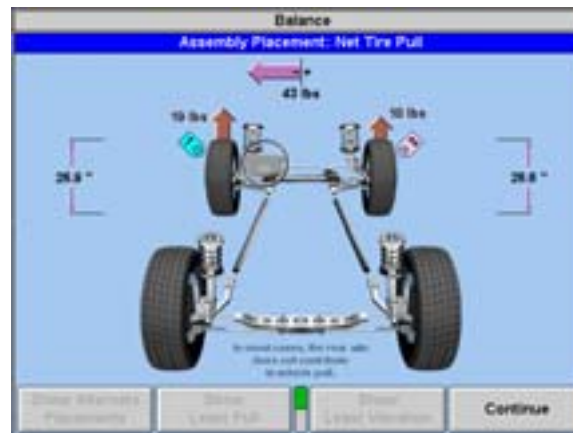

NOTE: The "Vehicle Plan View," showing tire/wheel assembly placement will appear only after two or more tire/wheel assemblies have been measured.

The vehicle plan view will show the net tire pull for the two measured tire/wheel assemblies.

Press "Continue" to return to the balance screen.

Mount the third tire/wheel assembly on the GSP9700 and perform ForceMatching (if needed) and balancing.

Press  "Tire Tags" to number the third tire/wheel assembly. The screen will default to tag 3.

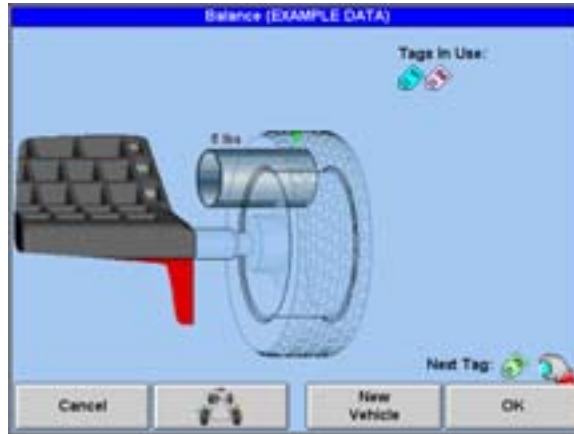

Press "OK" to accept tag 3. Refer to "Changing Tag Numbers," page 75.

After tagging the third tire/wheel assembly, the vehicle plan view will reappear. Refer to "Vehicle Plan View," page 74.

The vehicle plan view will show suggested placement of the tire/wheel assemblies so that the net lateral force, produced by tire conicity, exerted on the steer axle of the vehicle is minimized.

Press "Exit" to return to the balance screen.

Mount the fourth tire/wheel assembly on the GSP9700 and perform ForceMatching (if needed) and balancing.

Press  "Tire Tags" to identify the tire/wheel assembly. The screen will default to tag 4. Press "OK" to accept tag 4. Refer to "Changing Tag Numbers," page 75.

After tagging the fourth tire/wheel assembly, the vehicle plan view will reappear. Refer to "Vehicle Plan View," page 74.

On the Vehicle Plan View screen, various choices of tire placement may be chosen to optimize the vehicle for least pull and/or least vibration.

Disabling StraightTrak[®]

Any instance when lateral force is not an issue (such as when measuring single assemblies), StraightTrak[®] can be turned "OFF" to reduce cycle time. StraightTrak[®] can be disabled by turning the load roller activation knob clockwise until the  appears over the StraightTrak[®] logo.

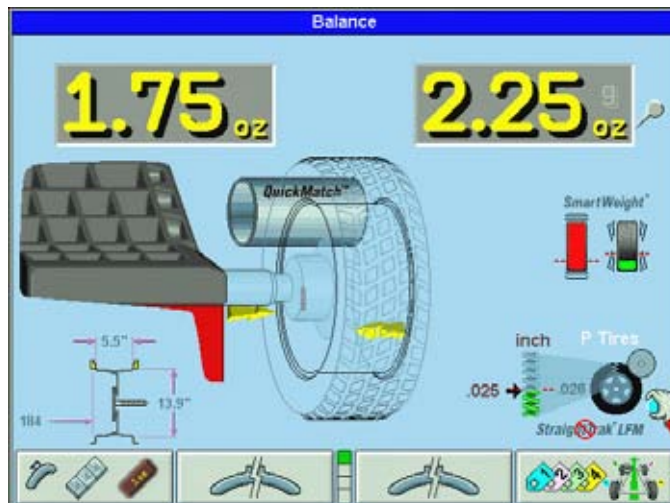

Vehicle Plan View

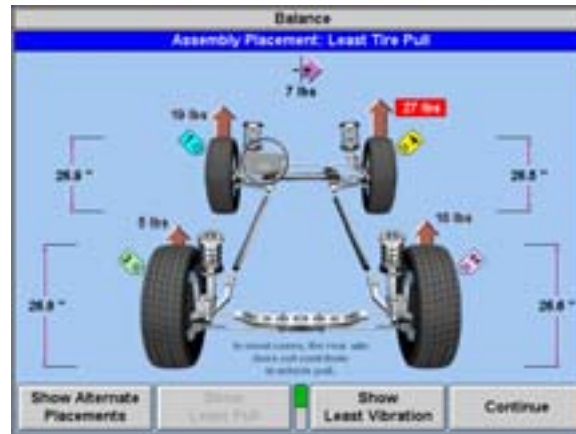

The vehicle plan view provides a graphic depiction of the information that is gathered by the GSP9700 during a loaded spin.



Net Tire Pull Arrow



Net pull indicates the direction and the magnitude of pull, due to the tires, that the vehicle will be subject to, if the tire/wheel assemblies are mounted on the vehicle as currently shown on the screen. Direction will be to the right (plus), or to the left (minus), and further indicated by an arrow. Magnitude is measured in pounds (lbs) or Newtons (N) and is further indicated by the length of the directional arrow.

While on the Vehicle Plan View, pressing  from the lower row of softkeys will keep the same amount of lateral pull, but reverse the direction. This is accomplished by swapping the positions of the two front tire/wheel assemblies. By default, lateral pull is set to the left to offset road crown. Each press of  will toggle the pull to the opposite direction, however it will remain in that direction until  is pressed again.

Road Force™ Arrows



Road force indicates the amount of vertical (radial) Road Force™ variation remaining in the tire/wheel assembly after ForceMatching™. Refer to “ForceMatching™,” page 61. Magnitude is measured in pounds (lbs), Newtons (N), or kilograms (kg). To minimize vibration, the tire/wheel assembly with the largest amount of road force is typically positioned farthest away from the driver (right rear). Even though the front (steer) axle tires may be switched to change the direction of net pull, the rear tire/wheel assembly with the largest amount of road force will still be positioned farthest away from the driver.

Changing Tag Numbers

The Changing Tag Numbers is the means of identifying each tire/wheel assembly during the StraightTrak® Lateral Force Measurement procedure. When the first tire/wheel assembly is ready to be tagged, the only option will be to tag it as tag 1. The second tire/wheel assembly will default to tag 2, however you may change it to tag 1 by rotating the control knob and then pressing “OK.” The third and fourth tire/wheel assemblies may be tagged by accepting the default (the next sequential tag) and pressing “OK,” or by rotating the control knob to a previous Changing Tag Numbers before pressing “OK.”

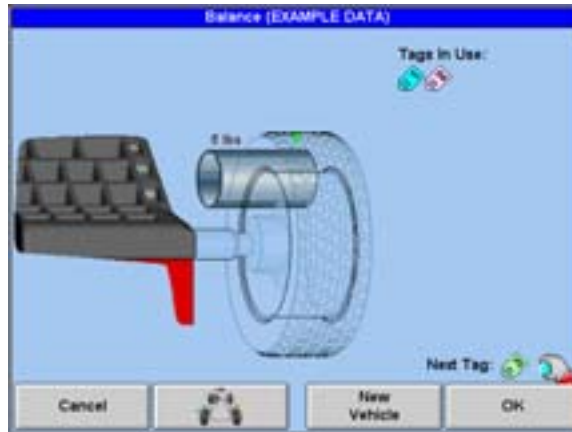

A measured and tagged tire/wheel assembly can be replaced by mounting a different tire, doing the lateral force measurement procedure, and then tagging the new tire/wheel assembly with the same number as the assembly that is being replaced. The new tire data will replace that of the original tire that is being replaced.

NOTE:

If a tire/wheel assembly is tagged as a number other than its default tag, information for the previously tagged (same Changing Tag Numbers) tire/wheel assembly will be deleted.

Example: Four tire/wheel assemblies have been measured and tagged with their default tags. Tire/wheel assembly 2 showed a significantly different amount of lateral pull (*refer to “Show Details,” page 77*), while the other assemblies were all very similar. If a different tire was mounted on rim 2 and it measured similar lateral pull to the other three assemblies, it would be desirable to include it with this set instead of the one tire that has a significantly different amount of pull. This fifth wheel/tire assembly could now be tagged as 2, eliminating the original measurement for tag 2.

Show Least Pull

By pressing “Show Least Pull,” the placement of tire/wheel assemblies on the vehicle that will yield the least net tire pull will be shown. This positioning tries to place the two tire/wheel assemblies on the front axle that have the same amount of pull, but in opposite directions when on the vehicle.

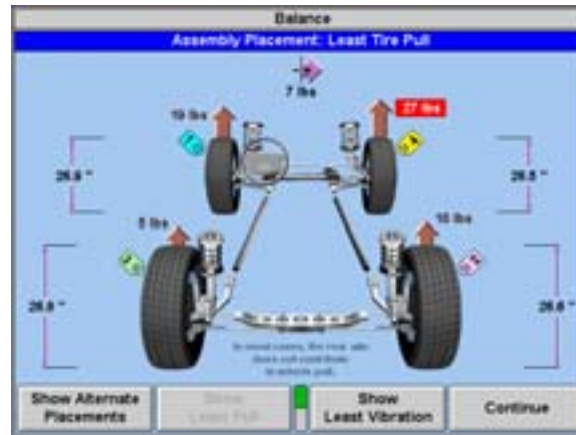

Lateral Force Results

Lateral force of a tire will cause the tire to pull inward or outward. As long as the lateral force of one tire is pulling in an equal and opposite direction of the other tire on the same axle, the vehicle will travel in a straight ahead direction, whether the amount of lateral force is small or large.

Show Least Vibration

By pressing “Show Least Vibration,” the placement of tire/wheel assemblies on the vehicle that will yield the least vibration will be shown. This positioning will place the tire/wheel assembly with the greatest amount of road force on the passenger side of the rear axle (farthest from the driver). The tire/wheel assembly with the second highest road force will be placed on the driver’s side of the rear axle, and the tire/wheel assembly with the lowest road force will be placed on the driver’s side of the front axle.

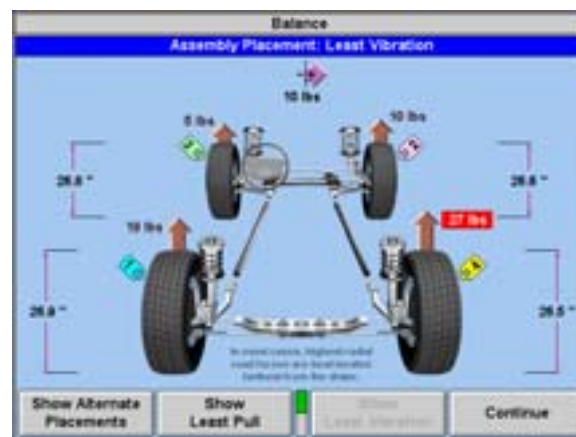

Show Alternate Placements

By pressing “Show Alternate Placements,” the result of each of six different combinations of placements of tire/wheel assemblies on the vehicle may be previewed. The first screen shown will be the configuration that will yield the least amount of net pull. Each press of the “Show Alternate Placements” softkey will show the configuration that will provide the next least amount of net pull.

Show Details

The net tire pull results of all alternate placements appear in a table on the summary printout and can be viewed on-screen by pressing the “Show Details” softkey on the second row of softkeys.

The following example shows a case where the “Show Details” softkey can help. With the tire/wheel assemblies positioned as recommended to provide least pull, a vibration could be induced, due to the large amount of radial force in tire/wheel assembly 4. By pressing “Show Details,” the net tire pull results of all alternate placements appear in a table. Using this “Details” table, look for the lowest value of net pull that does not use tire/wheel assembly 4 on the front axle. According to the table, placing tire/wheel assemblies 2 on the left and 3 on the right, a net pull of 10 pounds to the right would result. This placement would yield only a slightly higher net pull, however would minimize vibration by positioning tire/wheel assembly 4 opposite the driver on the rear axle.

NOTE: The table shows the same combinations that can be viewed by repeatedly pressing the “Show Alternate Placements” softkey.



Determining Tire Conicity Outliers

Locating one or more tires with a large difference in conicity may be achieved by using the “Show Details” graph. Locate one or more outliers by looking for high net pull examples when mixing tires.

Printout

The printout serves both the technician and the customer. If the GSP9700 is not equipped with a printer, it is recommended that the technician copy the information provided on the screen for reference. Keeping a record during service of the vehicle will allow the technician to be able to change tire/wheel positions after the “Vehicle Plan View” is reset.

If the GSP9700 is equipped with a printer, press “Print Summary” to print the summary.

By printing the summary, the technician has a printed reminder of where to position each tire/wheel assembly on the vehicle to minimize the effects of lateral force. If the desired results are not evident during a test drive, the technician may refer to the alternate placements shown on the printout, without the need to repeat the entire procedure.

The printout can be used to explain the effects of lateral force and the steps taken to reduce their adverse effect to the customer.

Inflation Pressure

Inflation pressure of each tire, as recorded by the Inflation Station, is displayed on the summary printout. A blank reading indicates that the tire was not measured (inflated or deflated) with the Inflation Station feature.

Summary printout will print the tire pressure rounded to the nearest tenth of a pound. The range allowable to fill each tire may vary on the printout by one or two pounds per assembly. This is considered normal due to the “green bar” tolerance allowable during automatic inflation.

4.8 Quick-Thread™ Feature

Quick-Thread™ is an “intelligent” DC drive motor control feature that allows motor assisted threading for fast installation and removal of the GSP9700 wing nut. Quick-Thread can be enabled or disabled from the “Setup” screen.

 **WARNING:** Keep clear of clamping components during Quick-Thread shaft rotation.

Lift the wheel assembly onto the shaft as normal without threading on the wing nut.

With your left hand, hold the rim over the cone to remove the weight of the rim from the spindle and to allow maximum quick-thread wing nut travel.

Place the wing nut on the spindle and rotate one full turn onto the spindle threads.

With your right hand, hold one handle of the wing nut while you are still lifting the rim.

NOTE: Heavier wheel assemblies may require extra lifting to prevent the software limited motor torque control from stopping the rotation of the spindle.

Tap the foot pedal twice and the spindle will rotate to install the wing nut to save threading time.

The direction of spindle rotation toggles each time it is used. For normal operation, spindle rotation will begin in the correct direction for wing nut installation. A single tap within the first three seconds of rotation will reverse the direction of rotation. A single tap after the first three seconds of rotation will stop rotation.

Quick-Thread spindle rotation will stop when the clamping components contact the wheel, or when the foot brake (*refer to “Spindle-Lok® Feature,” page 79*) is applied for more than half of a second.

 **CAUTION:** Quick-Thread does not tighten the wing nut! In Quick-Thread rotation, torque allowed is minimal. Therefore, you must still perform the final tightening of the wing nut.

NOTE: Also because of the software limited torque control, you must **loosen** the wing nut before Quick-Thread will remove it.

Quick-Thread will not operate if:

You are in “Diagnostics,” “Setup,” or all calibration procedures except “Servo-Stop.”

Either Dataset® arm is out of its “home position” while you are in the “Balance,” “Current Runout & Road Force” or “Measure Rim Runout” screens.

Inflation Station hose is out of its “home position.”

4.9 Motor Drive/Servo-Stop

The programmable DC motor drive on the GSP9700 is able to position and hold the tire assembly in position for weight application, apply different amounts of torque, and control the speed and direction of the spindle.

If Servo-Stop is enabled, when the “Start” button is pushed with the hood in the **raised** position, while weights are showing, the motor will automatically rotate the wheel to the next weight plane and hold the assembly in position for weight or ForceMatching Mark application.

Servo-Stop can be enabled or disabled from the “Set Up” primary screen. *Refer to “Setting Up the Servo-Stop/Servo-Push,” page 107.*

4.10 Spindle-Lok[®] Feature

Depressing the foot pedal will lock the spindle. Locking the spindle will stabilize the wheel for attaching weights at precise locations if automatic weight positioning is disabled, and will allow for tightening and loosening of the wing nut. Do not use the Spindle-Lok[®] as a brake to stop a spinning wheel.

NOTE:	Depressing the foot pedal will cancel Servo-Stop.
-------	---

 CAUTION:	Using the Spindle-Lok [®] to stop a spinning wheel may result in personal injury or damage to the balancer.
---	--

4.11 Hood Autostart Feature

The balancer can be set to automatically spin the wheel upon hood closure. After a spin, the hood must be lifted completely before the balancer will Autostart again.

For safety, the balancer will not Autostart in “Calibration,” “Setup,” “Diagnostics,” if no balancing procedure is selected, or if the Inflation Station hose is out of its “home position.”

The hood close Autostart feature can be enabled or disabled in the “Setup” procedure. *Refer to “Setting Up the Hood Autostart Feature,” page 107.*

4.12 Loose Hub Detect Feature

When the GSP9700 senses that the wheel is loose, it will automatically stop the spin. You should tighten the wing nut before proceeding.

NOTE:	If the wing nut appears to be tight, remove the wing nut and then clean and lubricate the spindle threads. <i>Refer to “Spindle Hub Face and Shaft Maintenance,” page 129.</i>
-------	--

4.13 Blinding and Rounding

If traditional balancing method is selected, the balancer can display either an “actual” or “blinded and rounded” amount of imbalance.

“Blind” is a tolerance or amount of imbalance required before an imbalance amount is displayed. “Round” allows the balancer to display weight imbalance to a desired increment. The blind and round values can be changed in the “Setup” procedure. Refer to “Service Mode Setup and Features,” page 111.

While in the “Balance” primary screen, blind and rounding may be disabled by rotating the control knob to highlight “”. The actual amounts of imbalance for the selected mode will be displayed when “Blind and Rounding” are disabled as shown below.

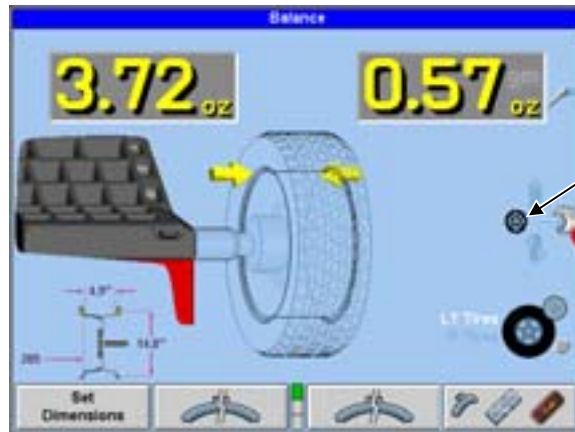

“BLIND AND
ROUNDING”
DISABLED

NOTE: SmartWeight™ balance method does not utilize a disabling feature for weight blinding. A disabled weight blinding feature is not necessary with SmartWeight and eliminates the need for this feature.

4.14 Inflation Station

Inflation Station provides preset tire pressure setting to ensure accurate Road Force™ Measurement (before and after matching) and safe assemblies for final mounting on the vehicle. The GSP9700 can reduce as well as increase the tire pressure.

NOTE: The Inflation Station is a factory installed feature that is not on earlier models of the GSP9700.

Lift the hose from the storage position (while in the “Balance” or “Runout & Road Force” screens) and the Inflation Station screen will automatically pop up.

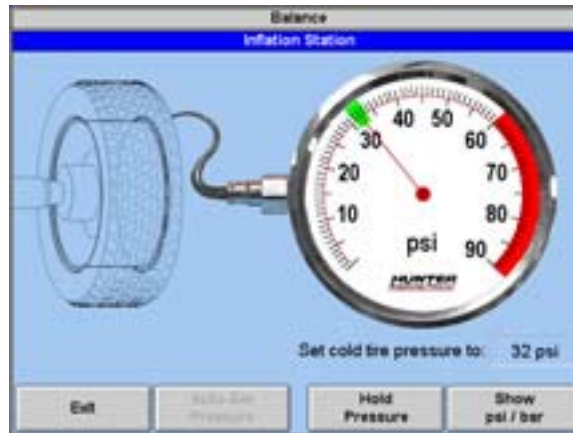

Upon sensing that the air hose is attached to the valve stem, the tire pressure will automatically be set to the target air pressure. The target air pressure is set by the user, by using the control knob.

In cases of a tire with pressure below 15 psi, “Auto-Set Pressure” can be selected to begin filling.

Press “Hold pressure” or “STOP” at any time to halt auto pressure setting.

Depending on “how far off,” the pressure is and how large the tire, the dialed-in pressure will usually be reached in three or less air “bursts” or “exhausts.” When the tire reaches the dialed-in pressure, the on-screen tire graphic will turn green.

The Inflation Station screen exits automatically when you remove the hose from the valve stem, or if you manually exit via the softkeys.

For safety, spinning is prevented for any of the following conditions: When the Inflation Station screen is showing, the hose is not at the storage position, or the hose is pressurized (not disconnected from the valve stem).

5. Balancing Features and Options

5.1 SmartWeight™ Balancing Technology

SmartWeight™ balancing technology revolutionizes the wheel balancing/vibration correction process. SmartWeight computes balancing correction weights in an effort to eliminate the static forces (up and down shake) and reduce couple forces (side to side shimmy) that are present in the tire and wheel assembly.

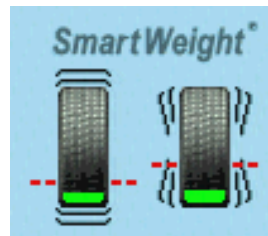

Standard balancing procedures attempt to eliminate these forces, often using excessive amounts of corrective weight. SmartWeight reduces these forces which result in less corrective weight used and improving the vibration identification and correction process. Instead of results reading “0” the display reads “OK.”



Not only does SmartWeight give the customer a better riding vehicle, it also helps the environment by using less corrective weight, and speeds up the wheel balance process which saves the shop time and money.

SmartWeight does not require any specific procedures to be performed. As long as SmartWeight has been selected it becomes an automatic process. Follow the normal balancing procedure and SmartWeight will compute the forces and the corrective weight.

Static and non-rounding modes are eliminated to simplify and eliminate operation. Always enter two weight positions during wheel measurement. All other functions are identical to the traditional balancing method.

SmartWeight will also compute the amount of weight saved over time. A histogram of weight savings statistics can be viewed from the “wake-up” screen.

5.2 WeightSaver™ Wheel Balancing Feature

Essentially, SmartWeight sets limits on the forces. WeightSaver adjusts the percentage of these forces to either save weight, or have a more fine-tuned balance. With SmartWeight, and bar graph in the green is within acceptable limits. WeightSaver allows that bar graph window to be changed.

The WeightSaver™ wheel balancing feature is a percentage of the force limit intentionally left in the assembly to save weights.

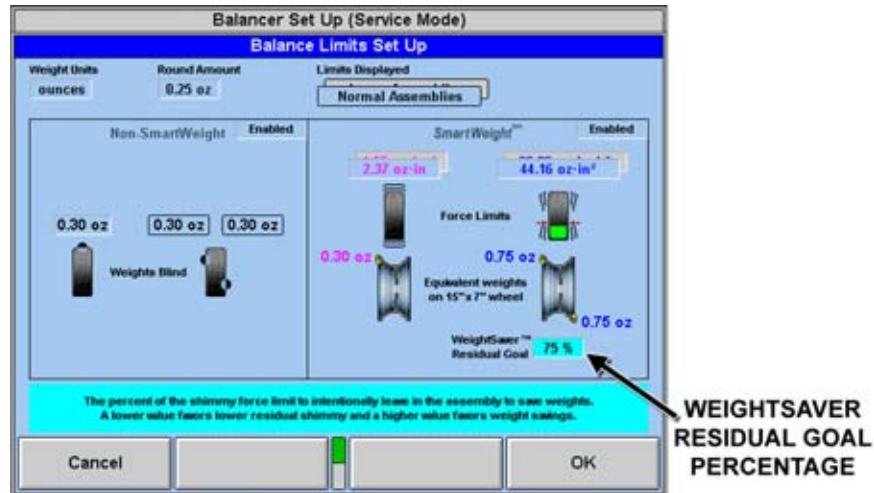

The lower the value favors a lower residual force and a higher value favors weight savings. The following example is set at the default of 75%.



The example below shows a 75% residual goal, which means that WeightSaver allows 75% of the maximum allowed force to remain. This saves more weight, saves time, and saves money.



5.3 Quick-Thread™ Feature

Quick-Thread™ is an "intelligent" DC drive motor control feature that allows motor assisted threading for fast installation and removal of the GSP9700 wing nut. Quick-Thread can be enabled or disabled from the "Setup" screen.

⚠ WARNING: Keep clear of clamping components during Quick-Thread shaft rotation.

Lift the wheel assembly onto the shaft as normal without threading on the wing nut.

With your left hand, hold the rim over the cone to remove the weight of the rim from the spindle and to allow maximum quick-thread wing nut travel.

Place the wing nut on the spindle and rotate one full turn onto the spindle threads.

With your right hand, hold one handle of the wing nut while you are still lifting the rim.

NOTE: Heavier wheel assemblies may require extra lifting to prevent the software limited motor torque control from stopping the rotation of the spindle.

Tap the foot pedal twice and the spindle will rotate to install the wing nut to save threading time.

The direction of spindle rotation toggles each time it is used. For normal operation, spindle rotation will begin in the correct direction for wing nut installation. A single tap within the first three seconds of rotation will reverse the direction of rotation. A single tap after the first three seconds of rotation will stop rotation.

Quick-Thread spindle rotation will stop when the clamping components contact the wheel, or when the foot brake (*refer to "Spindle-Lok[®] Feature," page 79*) is applied for more than half of a second.

 **CAUTION:** Quick-Thread does not tighten the wing nut! In Quick-Thread rotation, torque allowed is minimal. Therefore, you must still perform the final tightening of the wing nut.

NOTE: Also because of the software limited torque control, you must **loosen** the wing nut before Quick-Thread will remove it.

Quick-Thread will not operate if:

You are in "Diagnostics," "Setup," or all calibration procedures except "Servo-Stop."

Either Dataset[®] arm is out of its "home position" while you are in the "Balance," "Current Runout & Road Force" or "Measure Rim Runout" screens.

Inflation Station hose is out of its "home position."

5.4 Motor Drive/Servo-Stop

The intelligent DC motor drive on the GSP9700 is able to position and hold the tire assembly in position for weight application, apply different amounts of torque, and control the speed and direction of the spindle.

If Servo-Stop is enabled, when the "Start" button is pushed with the hood in the **raised** position, while weights are showing, the motor will automatically rotate the wheel to the next weight plane and hold the assembly in position for weight or ForceMatching Mark application.

Servo-Stop can be enabled or disabled from the "Set Up" primary screen. *Refer to "Setting Up the Servo-Stop/Servo-Push," page 107.*

5.5 Spindle-Lok[®] Feature

Depressing the foot pedal will lock the spindle. Locking the spindle will stabilize the wheel for attaching weights at precise locations if automatic weight positioning is disabled, and will allow for tightening and loosening of the wing nut. Do not use the Spindle-Lok[®] as a brake to stop a spinning wheel.

NOTE: Depressing the foot pedal will cancel Servo-Stop.

 **CAUTION:** Using the Spindle-Lok[®] to stop a spinning wheel may result in personal injury or damage to the balancer.

5.6 Hood Autostart Feature

The balancer can be set to automatically spin the wheel upon hood closure. After a spin, the hood must be lifted completely before the balancer will Autostart again.

For safety, the balancer will not Autostart in “Calibration,” “Setup,” “Diagnostics,” if no balancing procedure is selected, or if the Inflation Station hose is out of its “home position.”

The hood close Autostart feature can be enabled or disabled in the “Setup” procedure. Refer to “Setting Up the Hood Autostart Feature,” page 107.

5.7 Loose Hub Detect Feature

When the GSP9700 senses that the wheel is loose, it will automatically stop the spin. You should tighten the wing nut before proceeding.

NOTE:	If the wing nut appears to be tight, remove the wing nut and then clean and lubricate the spindle threads. Refer to “Spindle Hub Face and Shaft Maintenance,” page 129.
-------	---

5.8 Inflation Station

Inflation Station provides preset tire pressure setting to ensure accurate Road Force™ Measurement (before and after matching) and safe assemblies for final mounting on the vehicle. The GSP9700 can reduce as well as increase the tire pressure.

NOTE:	The Inflation Station is a factory installed feature that is not on earlier models of the GSP9700.
-------	--

Lift the hose from the storage position (while in the “Balance” or “Runout & Road Force” screens) and the Inflation Station screen will automatically pop up.

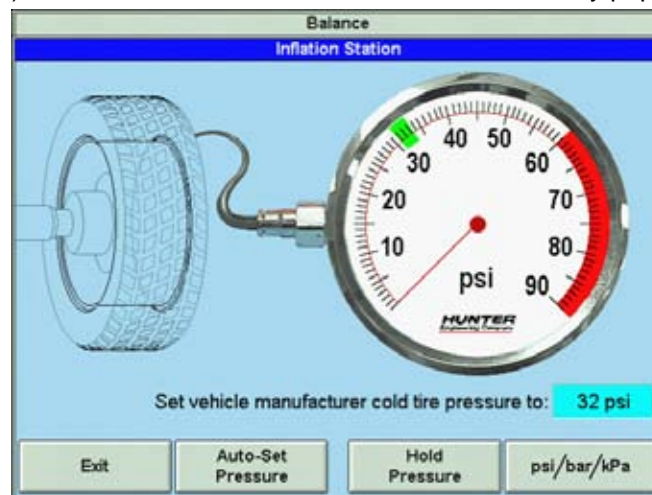

Use the control knob to adjust the desired air pressure limit.

Upon sensing that the air hose is attached to the valve stem, the tire pressure will automatically be set to the target air pressure.

In cases of a tire with pressure below 15 psi, “Auto-Set Pressure” can be selected to begin filling.

Press “Hold pressure” or “STOP” at any time to halt auto pressure setting.

Depending on “how far off,” the pressure is and how large the tire, the dialed-in pressure will usually be reached in three or less air “bursts” or “exhausts.” When the tire reaches the dialed-in pressure, the on-screen tire graphic will turn green.

The Inflation Station screen exits automatically when you remove the hose from the valve stem, or if you manually exit via the softkeys.

For safety, spinning is prevented for any of the following conditions: When the Inflation Station screen is showing, the hose is not at the storage position, or the hose is pressurized (not disconnected from the valve stem).

5.9 Split Weight® Feature

Press “” to change the required imbalance correction weight amount into two smaller size weights. The angle is adjusted by the balancer to produce the non-rounded correction called for by the single weight before split. This provides exact imbalance correction without weight trimming. The non-rounded imbalance is split regardless of whether blind and rounding are enabled. For this reason, Split Weight® is more accurate than applying a single weight with the blind and rounding enabled.

Split Weight® is especially useful when the imbalance amount is large or unavailable, such as 6.0 ounces. Split Weight® eliminates the error caused by placing two 3.0 ounce weights side-by-side, which would leave a substantial residual imbalance:

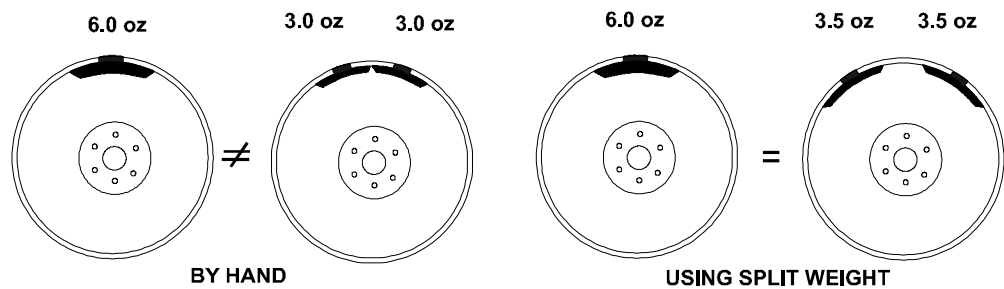

Use “” when the weight location interferes with a hubcap or trim ring, when one weight is too large, to avoid weight trimming, or to substitute for a weight size that is out of stock.

Split Weight® Operation

Each time “” is pressed, the two weights are increased to the next largest weight size and are placed (fanned out) further down the rim, as shown below.

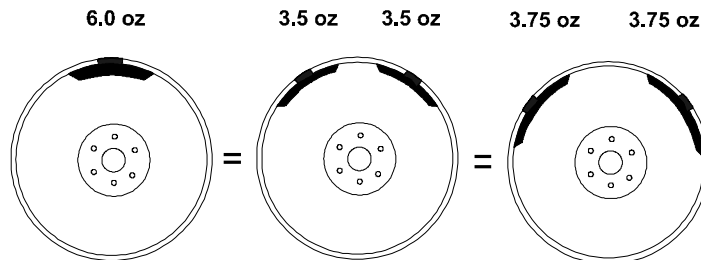

NOTE: To return to the original single weight, you can either toggle the control knob between static and dynamic, or continue to split the weight until all choices are exhausted.

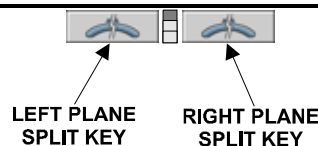

Press the green “START” button with the safety hood in the RAISED position and the GSP9700 will find the first split weight plane.

Attach the appropriate weight as displayed on the console.

Continue pressing “START” with the safety hood in the RAISED position and attaching the weights until all weights shown on the console have been applied.

Correcting Large Imbalances

Split Weight[®] can also be used to apply three weights when needed. For example, a large wheel may require 6.75 ounces. Not only is this size unlikely to be in the weight tray, but splitting 6.75 ounces would likewise result in large weights. In this case, apply one-third of the called for weight (in this case 2.25 ounces) at the 6.75 ounce weight location and spin the assembly again. The display will now call for a 4.5 ounce weight to be placed on top of the 2.25 ounce weight.

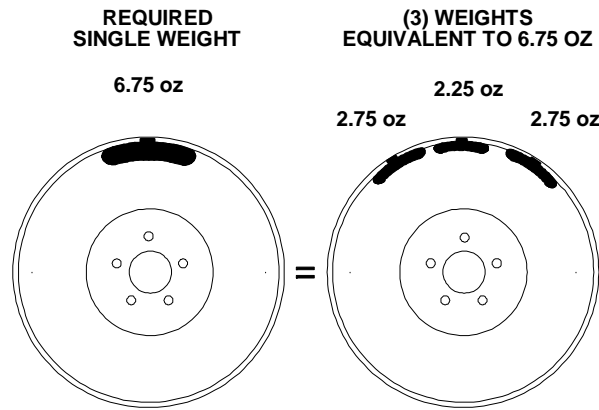

Press “” to fan out the two weights until they clear the previously applied 2.25 ounce weight. Then place the two indicated ounce weights on either side of the 2.25 ounce weight using the TDC indicators.

Another method to correct large imbalances may be achieved with Patch Balancing. Refer to “Patch Balance Procedure,” page 45.

5.10 Split Spoke[®] Feature

When in either mixed weight or adhesive weight modes, (dynamic or static), correction weights can be hidden behind the spokes of a wheel. The example below is in the mixed weight mode.

Hiding Adhesive Weight behind Spoke

Move the inner Dataset[®] arm to left weight plane position. Enter the data by pressing the foot pedal.

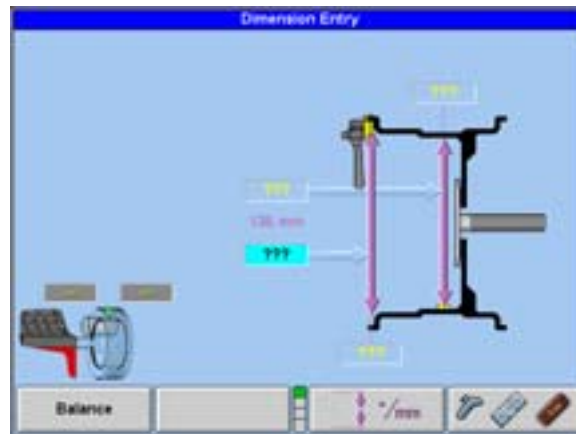

Move the inner Dataset[®] arm to the far right weight position, using the **DOWNWARD** arm position. Enter the data by pressing the foot pedal.



After inputting weight plane(s), the Split Spoke[®] feature may be initiated by the following steps before returning the arm to the “home” position:

Move the inner Dataset[®] arm to a position centered behind a spoke, using the **DOWNWARD** arm position. Enter the data by pressing the foot pedal.



Rotate the wheel to position the Dataset[®] arm behind an adjacent spoke (nearest spoke in either direction). Enter the data by pressing the foot pedal.



Return the inner Dataset[®] arm to the home position.

Close safety hood.

Press the green “START” button if “Hood Autostart” is disabled.

After wheel comes to a complete stop, raise safety hood.

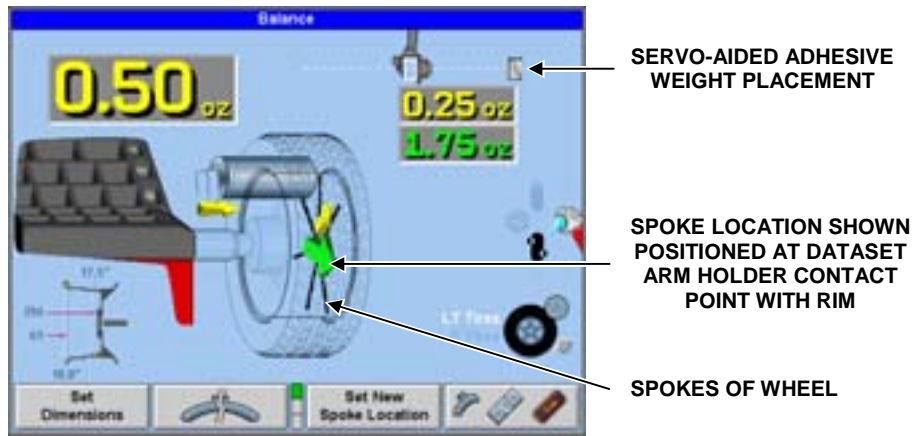

Place left plane weight (if in DYNAMIC mode) per the balance procedure being performed. Refer to “Balancing Procedures,” page 35.

Press the green “START” button with the safety hood in the RAISED position and the GSP9700 will servo to the location for the right adhesive weight plane (dynamic) or the static adhesive weight plane (static), aligned with the first spoke.

With the servo enabled, attach the adhesive weight behind the first spoke using the weight amount shown on the CRT. Refer to “Servo-Aided Adhesive Weight Placement,” page 51.

Press the green “START” button with the safety hood in the RAISED position and the GSP9700 will servo to the location for the second spoke.

Attach the appropriate weight as displayed on the console.

Verify balance condition by spinning again with the load roller disabled. Refer to “Load Roller Operation,” page 60.

All weight plane displays should show “zero.”

SPLIT SPOKE[®] balancing procedure is complete.

Re-entering Similar Wheel after Split Spoke[®] is Enabled

Once Split Spoke[®] mode is enabled, use the “Set New Spoke Location” key to input the spoke orientation of the other three rims from a set to avoid re-measuring the weight plane dimensions each time.



Move the inner Dataset[®] arm to a position centered behind a spoke, using the **DOWNWARD** arm position to align the spoke location. Enter the data by pressing the foot pedal.



Placing Hidden Weight Inside of Hollow Spokes

On some wheels, it may be possible to hide all of the right weight plane adhesive weights inside of the hollow spoke. However, wheel construction may make it impossible to enter the right weight plane with the inner Dataset arm.

The following example is in the mixed weight mode.

Move the inner Dataset[®] arm to left plane position. Enter the data by pressing the foot pedal.



Measure the distance from the left weight plane to the desired right weight plane, using a tape measure. This distance must be in millimeters (convert inches to millimeters by multiplying by 25.4).



Measure the weight plane diameter manually, using caliper.



NOTE: This may need to be done before the wheel is mounted on the GSP9700.

Add the measurement from the left weight plane to the desired right weight plane to the distance to the inner rim lip and enter this new dimension manually.

Enter the weight plane distance (mm) and diameter (in) manually.

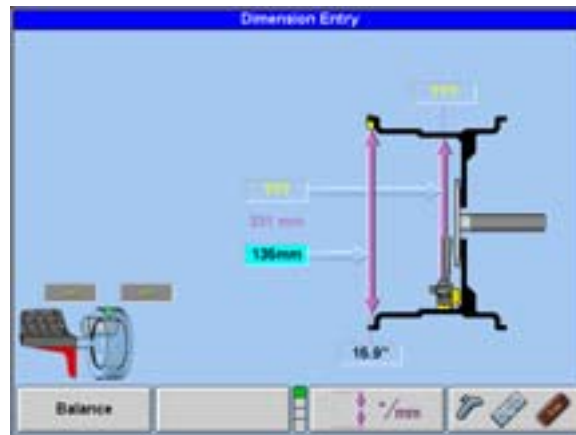

Close safety hood.

Press the green "START" button if "Hood Autostart" is disabled.

After wheel comes to a complete stop, raise safety hood.

Place left plane weight (if in DYNAMIC mode) per the balance procedure being performed. Refer to "Balancing Procedures," page 35.

Press the green "START" button with the safety hood in the RAISED position and the GSP9700 will servo to the location for the right adhesive weight plane (dynamic) or the static adhesive weight plane (static), aligned with the first spoke.

With the servo enabled, attach the adhesive weight behind the first spoke using the weight amount shown on the CRT.

Press the green "START" button with the safety hood in the RAISED position and the GSP9700 will servo to the location for the second spoke.

Attach the appropriate weight as displayed on the console.

Verify balance condition by spinning again with the load roller disabled. Refer to "Load Roller Operation," page 60.

All weight plane displays should show "zero."

SPLIT SPOKE® balancing procedure is complete.

5.11 MatchMaker™ Tire and Wheel Mounting Procedure

MatchMaker™ tire and wheel mounting procedure allows the operator to match four identical tires on identical rims, to achieve the optimal combination of match mounting. MatchMaker™ provides the operator with on-screen prompts throughout the procedure.

Tires Mounted on Rims

Mount the tire/wheel assembly on the GSP9700.

Check the tire pressure. Inflation Station will automatically inflate or deflate the tire to the preset air pressure. When the tire pressure is correct, the tire graphic on the screen will turn green. *Refer to “Inflation Station,” page 81.*

Measure rim runout by using the inner and outer dataset arms. *Refer to “Rim Runout Measurements,” page 54.*

Attach an identifying tag to the valve stem of the tire/wheel assembly. Using a tire crayon or other similar marking device, mark the tire with the same number (1-4) that is on the identifying tag.

NOTE:	The first tire/wheel assembly in a set must be identified as 1, the second assembly as 2, the third assembly as 3, and the last assembly as 4.
--------------	--

Rotate the tire/wheel assembly so that the mark on the on-screen tire is at the 12 o'clock position. Mark the sidewall of the tire at the 12 o'clock position.

Rotate the tire/wheel assembly so that the mark on the on-screen rim is at the 12 o'clock position. Mark the rim at the 12 o'clock position.

Press “OK.”

Repeat the procedure for the rest of the tire/wheel assemblies.

After repeating this procedure for all four tire/wheel assemblies, the screen will show which tires should be mounted on which rims to obtain the best results. You may choose to show tire/wheel matching based on the optimal road force or based on making less tire swaps.

Mount the tires to the rims (using the identifying tags attached to the valve stems and the numbers marked on the tires), aligning the marks on the sidewalls of the tires with the marks that were made on the rims.

Mount the matched tire/wheel assemblies on the GSP9700 and verify that the proper road force was achieved.

Balance each tire/wheel assembly using the appropriate balancing procedure for the particular type of rim construction. *Refer to “Balancing Procedures,” page 35.*

NOTE:	MatchMaker™ also supports measuring bare rims (requires extra dismount steps) as well as performing “Remount Centering Quality Checks” for increased accuracy.
--------------	--

Tires Not Mounted to Rims

Mount the bare rim on the GSP9700.

Measure rim runout by using the outer dataset arm. *Refer to "Rim Runout Measurements," page 54.*

Position the valve stem at the 12 o'clock position. Press "OK."

Attach an identifying tag to the valve stem of the rim.

Repeat the procedure for rims 2, 3, and 4.

<p>NOTE: The first rim assembly in a set must be identified as 1, the second as 2, the third as 3, and the last as 4.</p>
--

Mount tires onto the rims.

Mount the first tire/wheel assembly onto the GSP9700 with the valve stem at 12 o'clock. Press "OK."

Check the tire pressure. Inflation Station will automatically inflate or deflate the tire to the preset air pressure. When the tire pressure is correct, the tire graphic on the screen will turn green. *Refer to "Inflation Station," page 81.*

Measure rim runout by using the inner and outer dataset arms. *Refer to "Rim Runout Measurements," page 54.*

Using a tire crayon or other similar marking device, mark the tire with the same number (1-4) that is on the identifying tag.

Rotate the tire/wheel assembly so that the mark on the on-screen tire is at the 12 o'clock position. Mark the sidewall of the tire at the 12 o'clock position.

Rotate the tire/wheel assembly so that the mark on the on-screen rim is at the 12 o'clock position. Mark the rim at the 12 o'clock position.

Press "OK."

Repeat the procedure for the rest of the tire/wheel assemblies.

After repeating this procedure for all four tire/wheel assemblies, the screen will show which tires should be mounted on which rims to obtain the best results. You may choose to show tire/wheel matching based on the optimal road force or based on making fewer tire and rim swaps.

Mount the tires to the rims (using the identifying tags attached to the valve stems and the numbers marked on the tires), aligning the marks on the sidewalls of the tires with the marks that were made on the rims.

Mount the matched tire/wheel assemblies on the GSP9700 and verify that the proper road force was achieved.

Balance each tire/wheel assembly using the appropriate balancing procedure for the particular type of rim construction. *Refer to "Balancing Procedures," page 35.*

5.12 Diagnosis Explanation Screen (Limits Disabled)

After the Road Force™ Measurement and rim runout measurements have been taken, the GSP9700 will ask whether or not to perform QuickMatch. If any tire or rim assembly component exceeds a non-first harmonic limit, the “Diagnosis Explanation” popup screen will appear to provide a description of the component limit(s) exceeded. Refer to “Theory of Operation,” page 131.

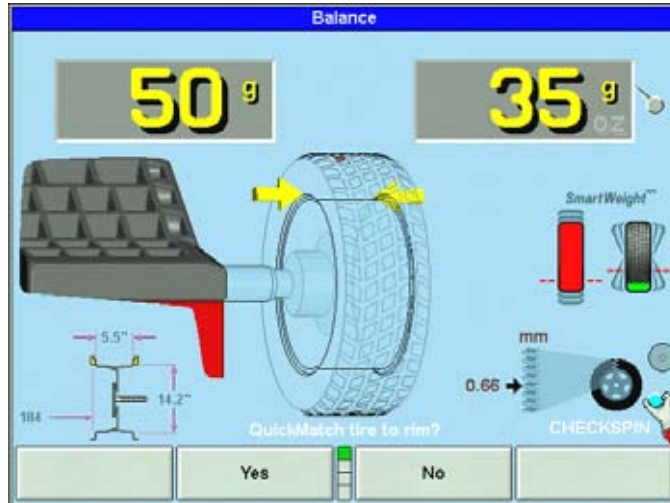

Tire and/or rim replacement may be suggested prior to ForceMatching™. When a severe rim condition is detected, the tire results may be affected.

5.13 Diagnosis Explanation Screen (Limits Enabled)

After the Road Force™ Measurement and rim runout measurements have been taken, the components are analyzed by the GSP9700 and compared to the limits. If any tire or rim assembly component exceeds a non-first harmonic limit, the “Diagnosis Explanation” popup screen will appear to provide a description of the component limit(s) exceeded. Refer to “Theory of Operation,” page 131. In this case, a prompt is indicating a rim T.I.R. limit is exceeded but is unlikely to cause a vibration.



Tire and/or rim replacement may be suggested prior to ForceMatching™. When a severe rim condition is detected, the tire results may be affected. In this case, a prompt is recommending that the tire be re-tested on a better rim.

5.14 Details Screen

From the “Diagnosis Explanation” screen, you may select to “Show Details.” The “Details” popup screen will present a charted depiction of each measured component and compare the measured data to the limits. Components that are not within limits, but are unlikely to cause vibration are shown in yellow. Components that are not within the limits and may cause vibration will be shown in red.

NOTE: Passenger car limits are more sensitive than light truck limits. Changing the “Passenger (P) or Light Truck (LT)” selection may change the exceeded limits.

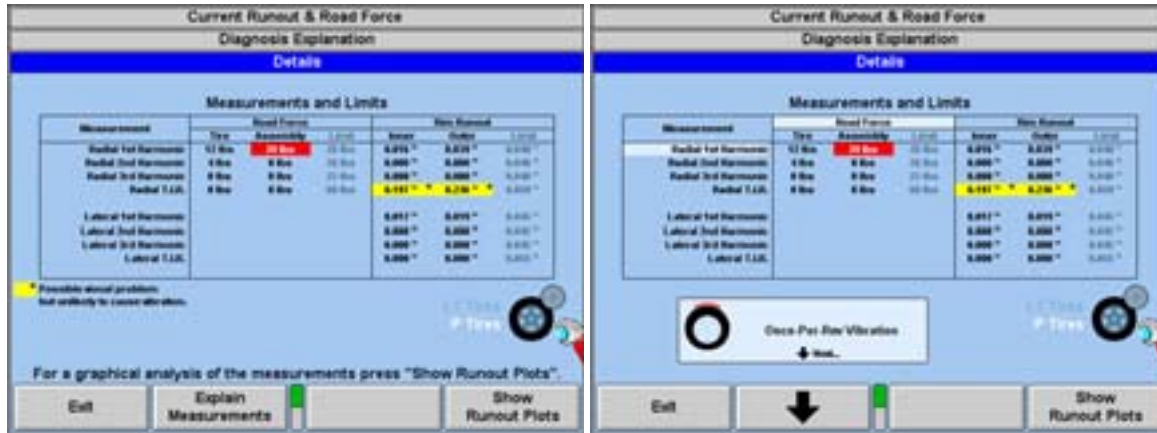

A graphic depiction and description of the measurement may be viewed by selecting “Explain Measurements” from the “Details” popup screen. As each measurement item is highlighted, the graphics will change to display the corresponding picture and description.

Some of the measurement descriptions that may be encountered include:

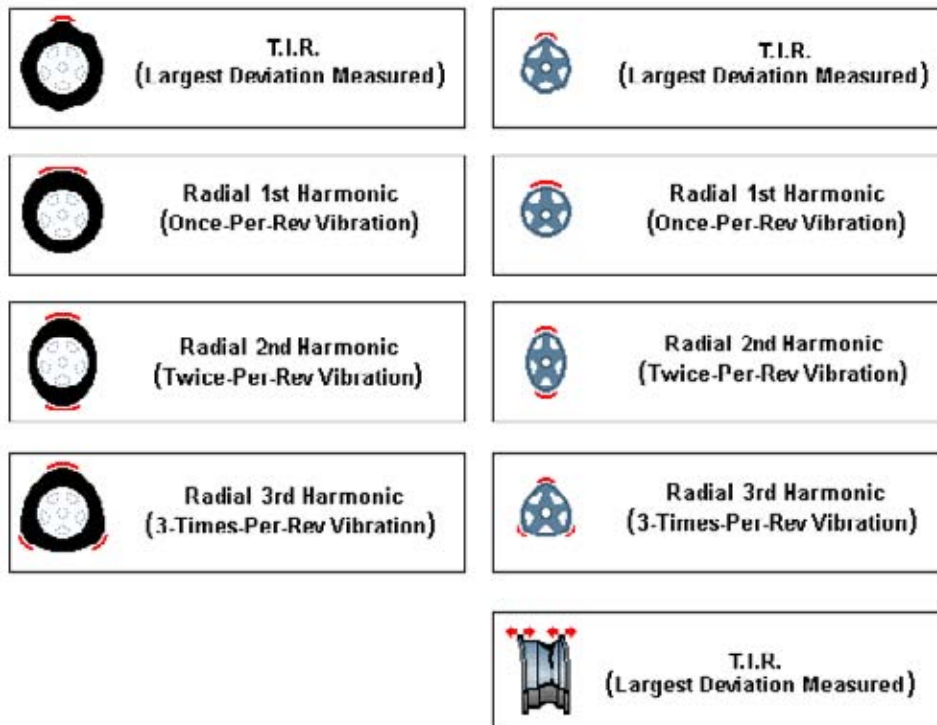

From the “Details” popup screen, “Show Runout Plots” may be selected. From this screen, a graphic depiction of the measured data, multiple harmonics, road force, and runout may be viewed. Refer to “Harmonics & T.I.R. Data/Plots,” page 98.

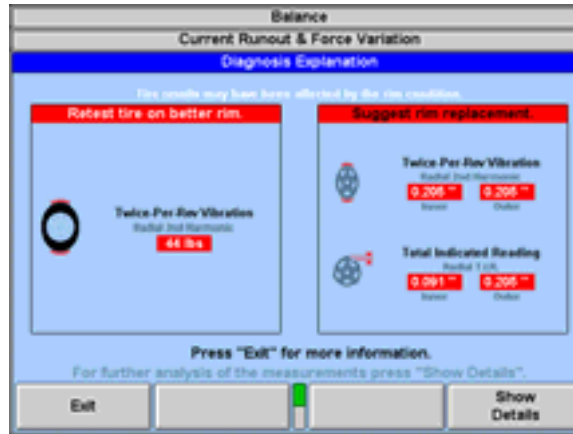

5.15 Print Summary

Balance and road force screens have “Print Summary” and “Save ‘Before’ Measurements” keys on the last key row. The printout combines data from the balance, road force, and diagnosis explanation (if it exists) screens, replacing up to four screen prints with one much faster formatted output.

Press the “Save ‘Before’ Measurements” key to save the balance, road force, and runout measurements for later printing along with measurements after balancing and ForceMatching.

NOTE:	“Before” measurements are retained only as long as power is left on.
-------	--

Imbalance condition, static vs. dynamic, and balance weight types are printed. Split and Spoke weight values are printed as the single weight equivalent (better indication of imbalance since weight angles are not printed).

The diagnosis box is printed along with assembly first harmonic result and the road force selector switch setting (P/SUV/LT). If non-first harmonic failures occur (the “Diagnosis Explanation” screen level exists), a second page is printed to show that data.

Tire road force and rim runout are not printed on the main printout page. If this information is desired, printing while in service mode will produce an additional page duplicating the charted information on the “Show Details” screen through fourth harmonics.

Print Summary While Matching Prediction Is Displayed:

If you have the road force screen set to “Show After ForceMatching” and then do a print summary, “Print Current” will print both the current and the predicted information on one page. Printing “Before and Current Measurements” together is not allowed in this case.

5.16 Harmonics & T.I.R. Data/Plots

A graphic depiction of the data displayed on the “Current Runout & Road Force” popup screen can be viewed by selecting “Show Runout Plots” from the “Details” popup screen.

The dotted line represents total indicated reading (T.I.R.), actual movement of the load roller or Dataset[®] arms. The total indicated reading numeric data displayed is the difference between the highest and lowest value measured. Harmonics are calculated from the T.I.R. data and then shown graphed as a solid curve. The harmonic numeric data displayed represents the difference between the highest and lowest value of the curve. Refer to “Harmonic Vibrations,” page 131. During ForceMatching™, the first harmonic vibration of the tire is matched opposite of the first harmonic vibration of the rim (average of the inner and outer measured flanges or bead seats) to reduce the vibration of the wheel assembly. Refer to “ForceMatching™,” page 61.

Viewing Multiple Harmonics

You may also select to see plots of multiple harmonic vibrations for the assembly, tire or rim. Each time “Show Next Harmonic” is selected, the next harmonic amount will be highlighted in color and the corresponding harmonic curve (such as a twice-per revolution wave representing the second harmonic) will be plotted on the graph and sized according to the highlighted amount.

Viewing Multiple Revolutions

The runout plots automatically show one complete revolution of the assembly by default. The “Show All Revolutions” key may be selected to show all four measured revolutions of data on the load roller plot or the two revolutions of data on the rim plots. This makes it possible to view the data for consistency in measurement for each revolution.

Assembly Data Plots Screen

When “Show Runout Plots” is selected, the “Rim and Load Roller Runout Plots” screen will appear. The initial screen defaults to the first harmonic plot of the load roller data for the assembly. The assembly lines are color coded to represent a specific value as follows:

LINE COLOR	DESCRIPTION
White	T.I.R. data of the rim/tire assembly loaded road force.
Brown	1st Harmonic vibration for rim/tire assembly.

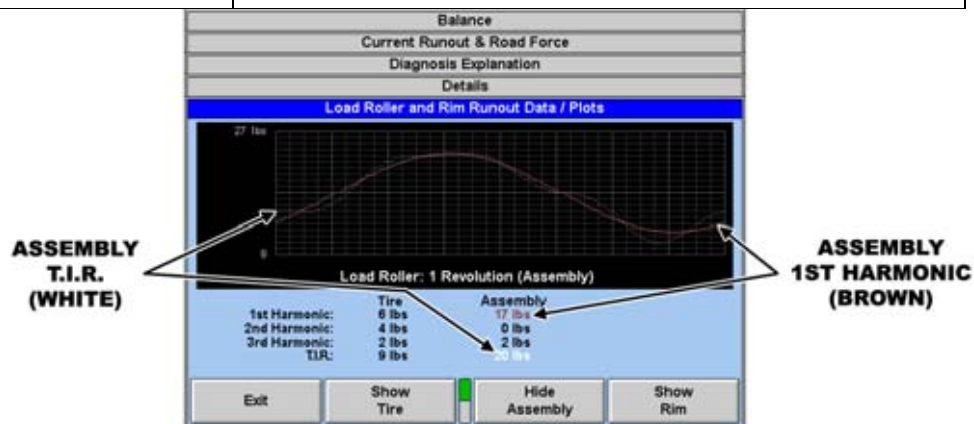

Tire Data Plots Screen

Selecting “Show Tire” will show the tire harmonic and total indicated reading of runout data with the rim contribution removed. The “Tire” lines are color coded to represent a specific value as follows:

LINE COLOR	DESCRIPTION
Violet	T.I.R. data for tire.
Yellow	1st Harmonic vibration for tire.

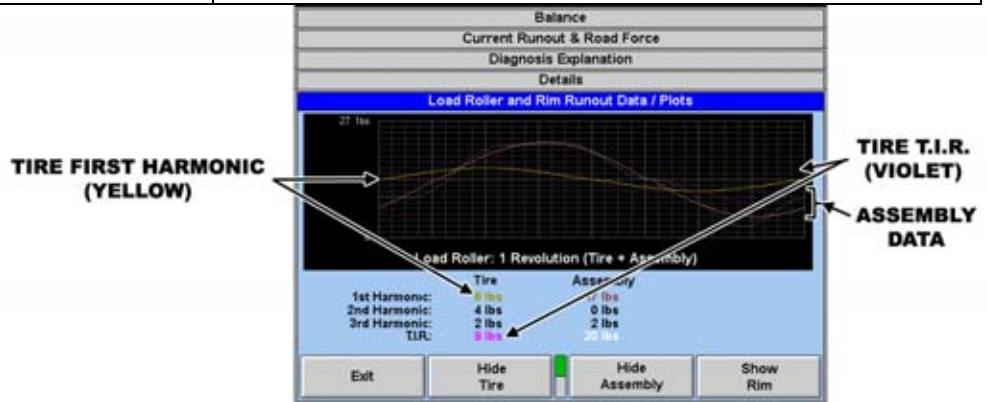

Selecting “Hide Tire” or “Hide Assembly” from the Load Roller Runout Plot Screen will conceal the corresponding plot from view. This makes it easier to examine individual data or print a specific plot.

From the second menu row, selections for multiple harmonics and multiple revolutions of data are available. You may select to see any combination of data, harmonics, and revolutions desired.

For instance, the plot below shows the four revolutions for the first harmonic for assembly loaded road force data.

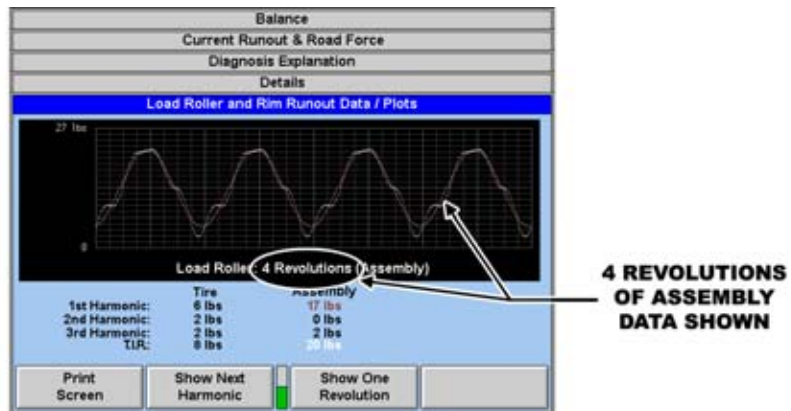

Selecting “Show One Revolution” will return the data to the single revolution plot.

5.17 Statistics

Show Statistics

From the “GSP9700 Series **Road Force Measurement System**” logo screen, “View Statistics” may be selected from the second menu tier. This allows a tally of the spins to be categorized by their road force, radial runout, and lateral runout measurements and viewed or printed for statistical purposes.

NOTE: The statistics screen does not tally balance results.

The Hunter GSP9700 Road Force Measurement System				
Statistics: 1st Harmonic				
Spins, Tire	Spins, Assy	Spins, Rad Rnt	Spins, Lat Rnt	Spins, Avg Rad Rnt
0 .000 -> .005"	0 .000 -> .005"	0 .000 -> .005"	0 .000 -> .005"	0 .000 -> .005"
0 .000 -> .010"	0 .000 -> .010"	0 .000 -> .010"	1 .000 -> .010"	2 .000 -> .010"
0 .011 -> .015"	0 .011 -> .015"	4 .011 -> .015"	2 .011 -> .015"	3 .011 -> .015"
0 .016 -> .020"	0 .016 -> .020"	0 .016 -> .020"	5 .016 -> .020"	0 .016 -> .020"
0 .021 -> .025"	1 .021 -> .025"	1 .021 -> .025"	0 .021 -> .025"	1 .021 -> .025"
1 .026 -> .030"	2 .026 -> .030"	2 .026 -> .030"	0 .026 -> .030"	2 .026 -> .030"
0 .031 -> .035"	10 .031 -> .035"	1 .031 -> .035"	0 .031 -> .035"	0 .031 -> .035"
2 .036 -> .040"	0 .036 -> .040"	0 .036 -> .040"	0 .036 -> .040"	0 .036 -> .040"
3 .041 -> .045"	0 .041 -> .045"	0 .041 -> .045"	0 .041 -> .045"	0 .041 -> .045"
0 .046 -> .050"	0 .046 -> .050"	0 .046 -> .050"	0 .046 -> .050"	0 .046 -> .050"
0 .051 -> .055"	0 .051 -> .055"	0 .051 -> .055"	0 .051 -> .055"	0 .051 -> .055"
1 .056 -> .060"	0 .056 -> .060"	0 .056 -> .060"	0 .056 -> .060"	0 .056 -> .060"
0 .061 -> .065"	0 .061 -> .065"	0 .061 -> .065"	0 .061 -> .065"	0 .061 -> .065"
0 .066 -> .070"	0 .066 -> .070"	0 .066 -> .070"	0 .066 -> .070"	0 .066 -> .070"
0 .071 -> .075"	0 .071 -> .075"	0 .071 -> .075"	0 .071 -> .075"	0 .071 -> .075"
0 .076 -> .080"	0 .076 -> .080"	0 .076 -> .080"	0 .076 -> .080"	0 .076 -> .080"
0 .081 -> .085"	0 .081 -> .085"	0 .081 -> .085"	0 .081 -> .085"	0 .081 -> .085"
0 .086 -> .090"	0 .086 -> .090"	0 .086 -> .090"	0 .086 -> .090"	0 .086 -> .090"
0 .091 -> .095"	0 .091 -> .095"	0 .091 -> .095"	0 .091 -> .095"	0 .091 -> .095"
0 .096 -> .100"	0 .096 -> .100"	0 .096 -> .100"	0 .096 -> .100"	0 .096 -> .100"
0 .> .100"	0 .> .100"	0 .> .100"	0 .> .100"	0 .> .100"
7 Total	16 Total	8 Total	8 Total	8 Total

The first statistics screen, shown above, represents spin counts for first harmonic results. Columns 3 and 4 show the larger runout amount of the two measured rim lips for each spin (the smaller values for each spin are not stored). Column 5 shows the radial average of the two rim lips. The rim average is used for ForceMatching™, therefore use this column as an indicator of how much matchable rim runout was measured by the GSP9700 compared to how much tire (and assembly) road force was measured (columns 1 and 2).

The “Show More Statistics” key can be selected to show second harmonic, third harmonic, and T.I.R. results for all spins. Column 5, rim average data, will not be shown in these cases.

If the GSP9700 is equipped with StraightTrak® LFM, there will be a page of lateral force statistics following the T.I.R. results.

“Clear Data” can also be selected (key is only available in Service Mode) to erase the tabulated statistics data.

If statistics are displayed in metric units, then the displayed ranges will be converted from inches to millimeters and from pounds to kilograms.

Weight Savings

Select **Show Weight Savings** from the main logo screen to view a statistical page of balance figures classified by type of weight and rim diameter.

	«-14"	15"->17"	18"->20"	21"->23"	24"-»	Total
Clip-Clip						
Spins:	36	20	4	4	0	64
Non-SmartWt:	120.75	62.00	10.00	9.25	0.00	202.00oz
SmartWt:	85.75	46.00	8.25	7.50	0.00	147.50oz
Savings:	35.00	16.00	1.75	1.75	0.00	54.50oz
	29.0 %	25.8 %	17.5 %	18.9 %	0.0 %	27.0 %
1 wt req'd:	11	7	3	1	0	22
no wts req'd:	3	1	1	0	0	5
Clip-Tape						
Spins:	0	0	0	4	0	20
Non-SmartWt:	0.00	57.75	49.50	20.75	0.00	128.00oz
SmartWt:	0.00	37.50	35.75	15.00	0.00	88.25oz
Savings:	0.00	20.25	13.75	5.75	0.00	39.75oz
	0.0 %	35.1 %	27.8 %	27.7 %	0.0 %	31.1 %
1 wt req'd:	0	3	5	1	0	9
no wts req'd:	0	2	1	0	0	3
Tape-Tape						
Spins:	0	16	12	4	4	36
Non-SmartWt:	0.00	117.75	65.25	26.25	13.50	222.75oz
SmartWt:	0.00	79.25	41.75	18.25	9.75	148.00oz
Savings:	0.00	47.50	23.50	8.00	3.75	82.75oz
	0.0 %	40.3 %	36.0 %	30.5 %	27.8 %	37.1 %
1 wt req'd:	0	5	3	1	2	11
no wts req'd:	0	1	0	0	0	1
Totals						
Spins:						120
Non-SmartWt:						552.75oz
SmartWt:						375.75oz
Savings:						177.00oz
						32.0 %
1 wt req'd:						42
no wts req'd:						9

The page shows the amount of weight savings, highlighted in blue, using SmartWeight™ balancing technology. The savings are shown in both actual weight and percentage.

The statistics can be cleared by selecting "Clear Data" from the second tier of softkeys. This could be used if tracking weight during a specific period. The "Clear Data" key may only be selected when in Service Mode. *For more information refer to "Service Mode Setup and Features," page 111.*

Weight savings can also be cleared by changing the SmartWeight™ settings. Once the settings have been changed, the past results will no longer apply to the current settings.

Select "Print Screen" to print the figures displayed.

Rim Data Plots Screen

“Show Rim” may be selected to view rim runout at the inner and outer measured flanges (Refer to “Rim Runout Measurement-Wheel Assembly,” page 54) or bead seats (Refer to “Rim Runout Measurement-Bare Rim,” page 56).

The screen defaults to the inner radial rim data. From this screen, you may select to view lateral or radial runout for the inner or outer rim data plot screens. The lines are color coded to represent a specific value as follows:

LINE COLOR	DESCRIPTION
White	T.I.R. data for the rim. (Inner or Outer)
Blue	Radial runout harmonic vibration for rim. (Inner or Outer)
Orange	Lateral runout harmonic vibration for rim. (Inner or Outer)

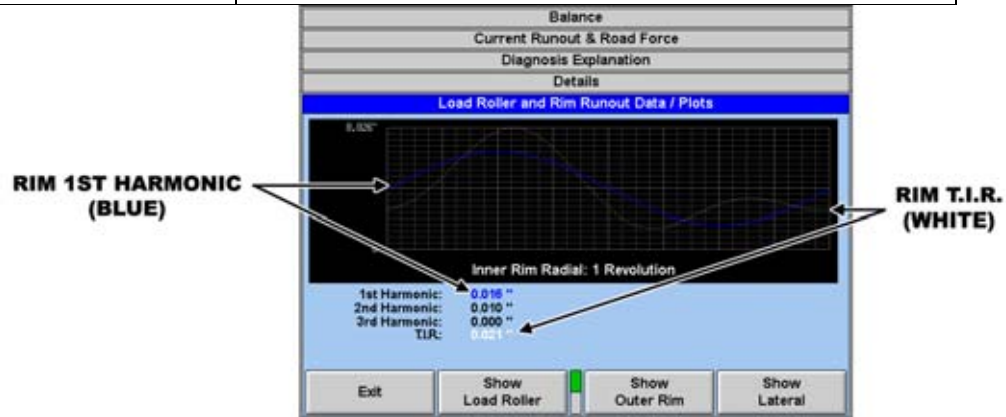

Viewing Multiple Harmonics

You may also select to see additional harmonic vibration measurements of the rim data. Each time “Show Next Harmonic” is selected, the next harmonic amount will be highlighted in color and the corresponding harmonic curve will be plotted on the graph and sized according to the highlighted amount.

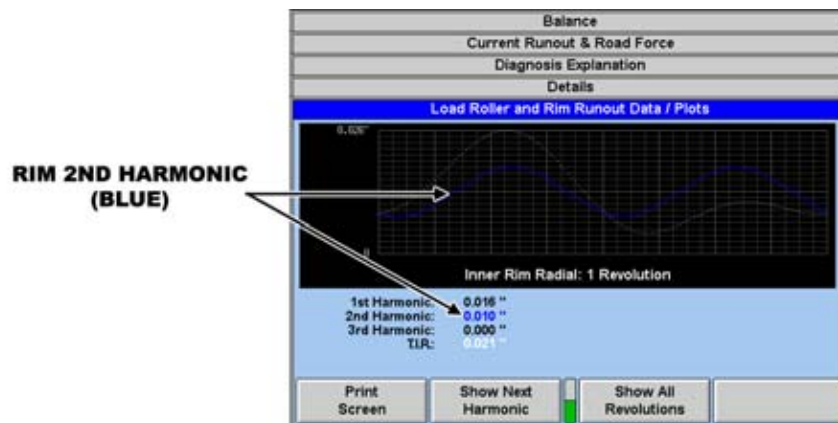

From the first menu row, you may select “Show Load Roller” to return to the load roller screen viewed prior to selecting the “Show Rim” key.

From the first menu row, you may select “Exit” to return to the “Current Runout & Road Force” screen.

6. Equipment Information

6.1 Software Identification

Selecting “Identify Software” from the logo screen will display the software version, and all installed features and trademarks.



6.2 Program Cartridge Removal and Installation

CAUTION: Only a Hunter authorized service representative should perform this procedure. A static wrist strap should be worn to prevent damage to static sensitive parts.

NOTE: Customer settings should be recorded prior to cartridge replacement.

Turn the unit power “OFF” and disconnect the AC power cord from the power source.

Remove the two Phillips screws securing the access panel to the rear of the CRT support console and remove the access panel.



Remove the installed program cartridge from the CRT support console.

Insert the new program cartridge into the console. Ensure proper alignment of the cartridge guides with the console alignment guides. Press the cartridge into the data communications board receptacle.

Reinstall the access panel and secure with the two Phillips screws previously removed.

Re-attach the AC power cord, turn the unit "ON" and verify operation.

AFTER INSTALLING PROGRAM CARTRIDGE:

View setup options by selecting "Setup" from the "Balance" primary screen. Change setup options to the desired settings. Press "Store Setup" to complete "Setup" procedures.

NOTE: **The GSP9700 may request to be completely re-calibrated after program cartridge installation.** Refer to "Calibration Procedures," page 116. Calibration tool, 221-602-1, is required.

6.3 Balancer Set Up

The "Set Up" primary screen contains a list box of set up items and may be selected from the second row of softkeys on the "Logo" primary screen. As the set up features are individually highlighted by selecting "↑" or "↓", the equipment components for each set up procedure are shown in yellow on the illustrated GSP9700.

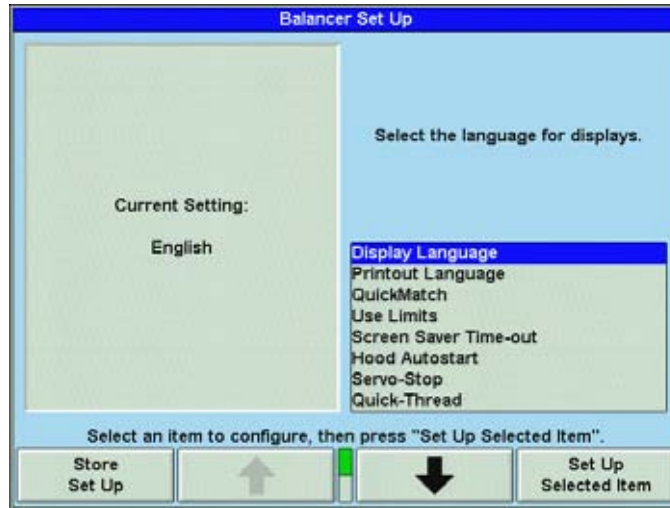

Change set up features by selecting "Set Up Selected Item." The gray box at the top of the item set up menu displays the current setting for each feature. The blue box in the middle of the set up screen describes the highlighted choice from the list box below. Use the soft keys to select the desired setting for each feature. Select "OK" when the desired choice is highlighted. To exit set up procedures and save changes that were made, select "Store Set Up" from the menu. The screen will automatically return to the "Logo" screen.

NOTE: The set up information is not stored until "Store Set Up" is pressed on the wheel balancer "Set Up" screen.

To abandon the set up procedures without saving changes, select the "Cancel" key or simply reset the system.

Setting Up the Display Language

Selects the language for displays.

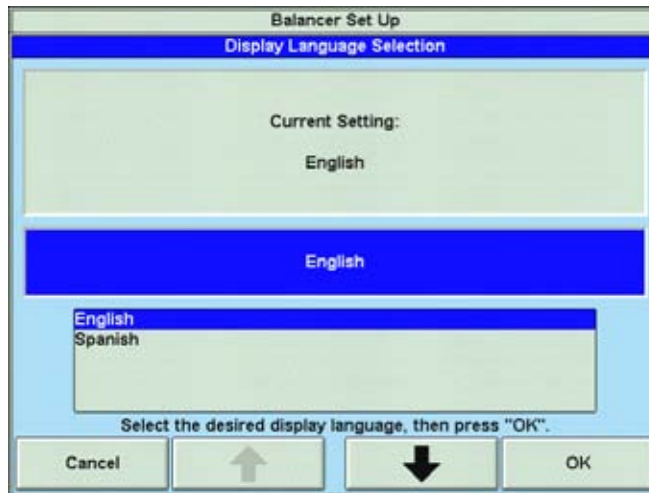

Setting Up the Printout Language

Selects the language for printouts.

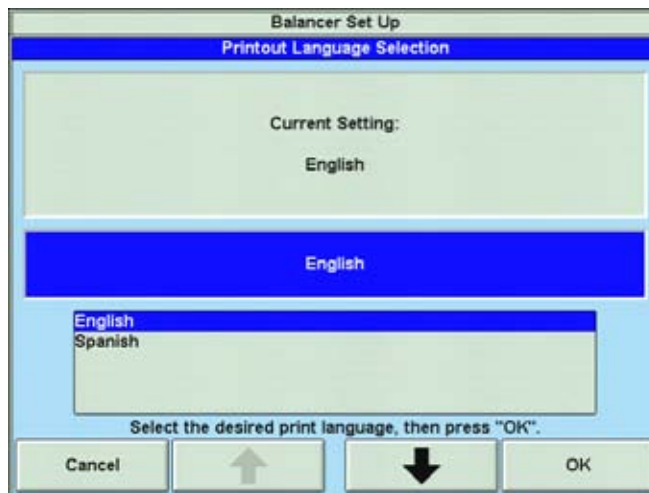

Setting Up the QuickMatch® Feature

QuickMatch can be disabled, enabled, or enabled with the toggle key.

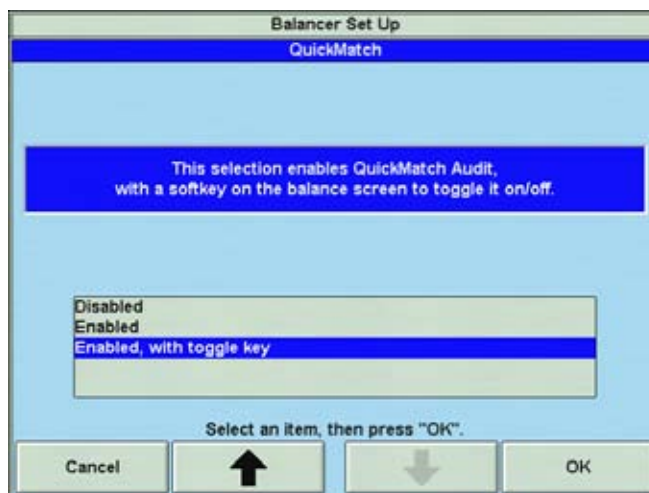

Setting Up the Use Limits Feature

This set up choice will allow the operator to enable or disable Runout & Road Force limits.

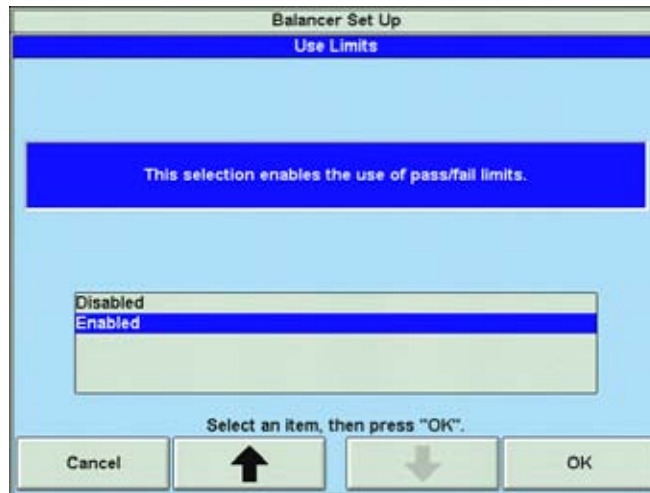

If this is disabled, there will be no Road Force™ failures and many diagnostic messages will not be shown.

NOTE:	If this is disabled, you will not see "Runout & Road Force Limits" on the setup menu. There will also be no choice to set limits on the RoadForce roller from the balance screen.
-------	---

Setting Up the Screen Saver Time-out

Selects the amount of inactive time that causes the screen saver to activate. Screen saver time out options include 1 minute, 5 minutes, 15 minutes, and Disabled.



Setting Up the Hood Autostart Feature

Enables or disables automatically starting the spin upon closing the hood.

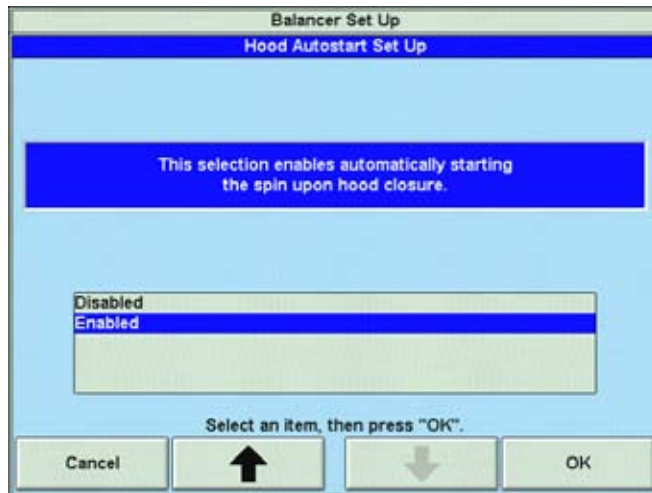

Setting Up the Servo-Stop/Servo-Push

Enables or disables the intelligent DC motor drive to automatically rotate the wheel to the weight or ForceMatch mark positions. Servo-Push may also be enabled, which allows pushing the wheel (approximately 1/8 of a revolution) to cause the intelligent DC motor drive to automatically rotate the wheel to the next weight or ForceMatch Mark positions. Pressing the "START" key may still be used for this function.

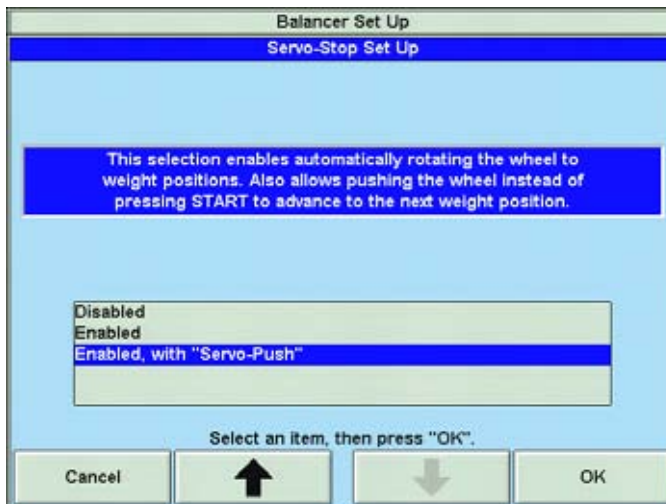

Setting Up the Quick-Thread™ Feature

Enables or disables motor assisted threading of the wing nut.

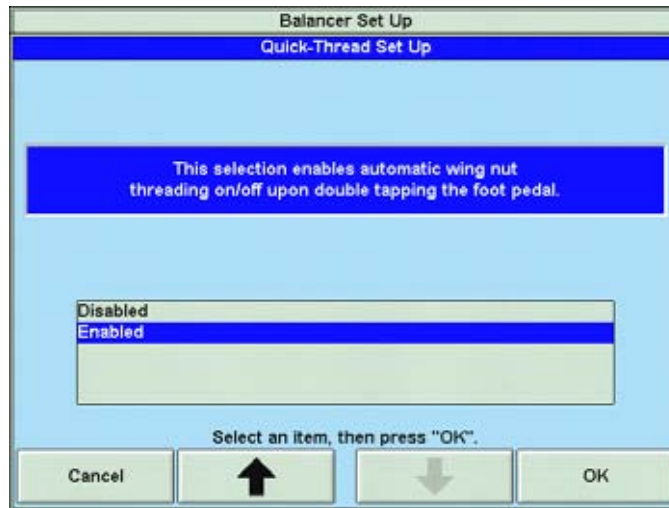

Setting Up the Balance Check Spin

Enables or disables the load roller during balance verification spins. When enabled the load roller will automatically disabled as necessary.



Setting Up the Weight Units

Selects the Weight Units setting for start-up of the GSP9700. This will set ounces or grams as the default unit of measurement.

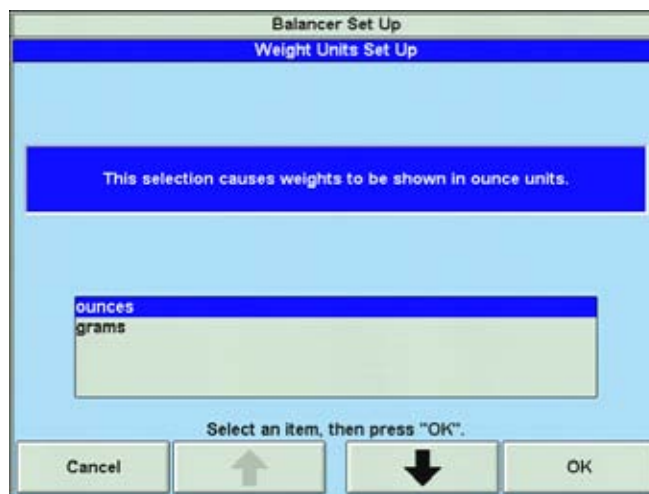

Setting Up the Inflation Station Units

Selects English or Metric units for air pressure, or disable the option altogether.

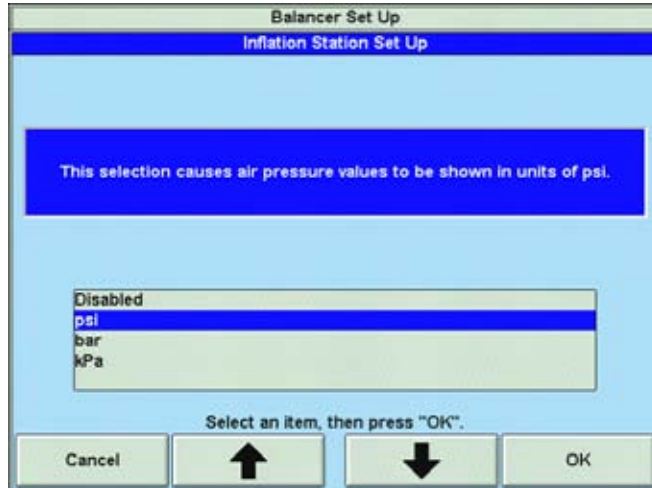

Setting Up the Runout Units

Selects English or Metric units for displaying runout measurements.

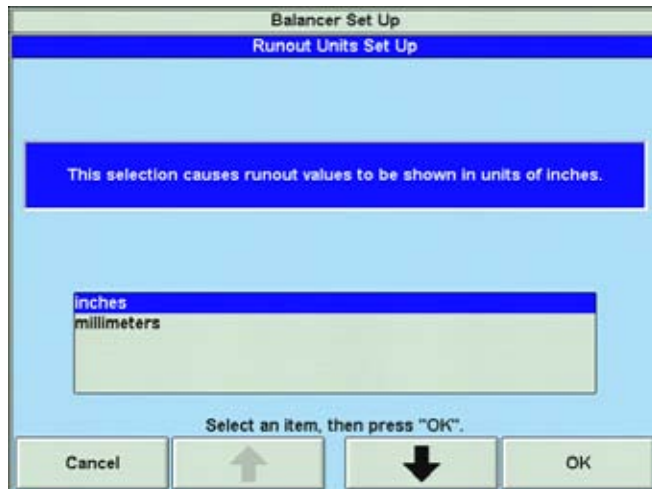

Setting Up the Road Force Units

Selects the desired units for road force measurement to be displayed on the screen and in printouts. Select units in pounds, Newtons, or kilograms.

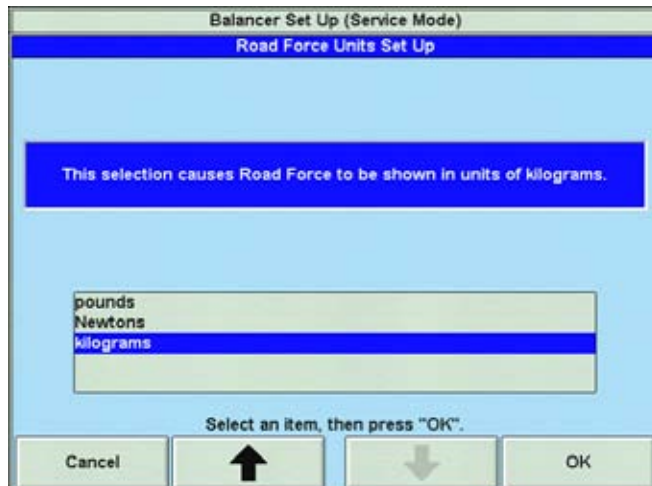

Setting Up the Prompted Inflation Station

Enables or disables the program to automatically prompt the user to set tire pressure.

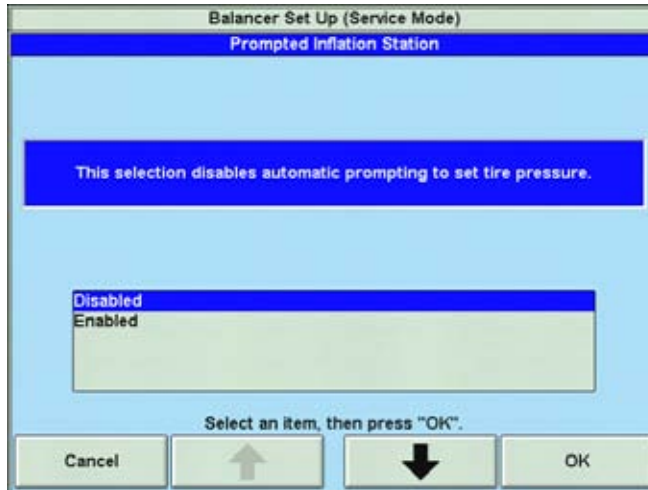

Setting Up the Prompted Centering Checks

Enables or disables the program to automatically prompt the user to perform a centering check on each wheel.

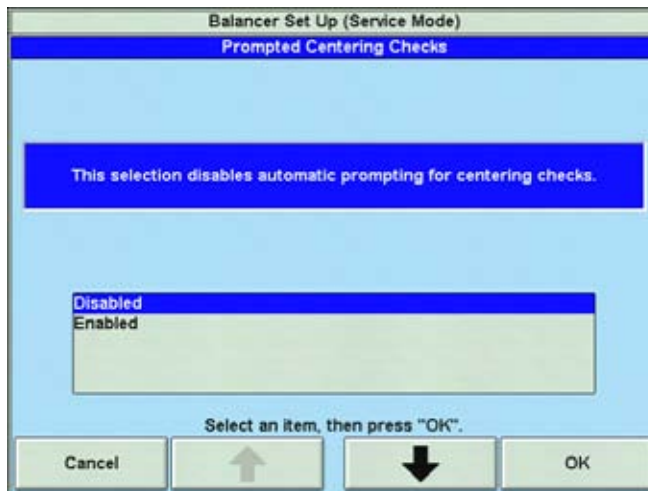

6.4 Service Mode Setup and Features

NOTE: Service Mode should only be used by advanced users or Hunter Engineering Company authorized service personnel.

By pressing K2 and K3 during boot up or reset twice, the GSP9700 will enter its “Service Mode” enabling the selection of advanced customized settings and hardware specific setup. “Service Mode” will then be displayed at the top of the screen.

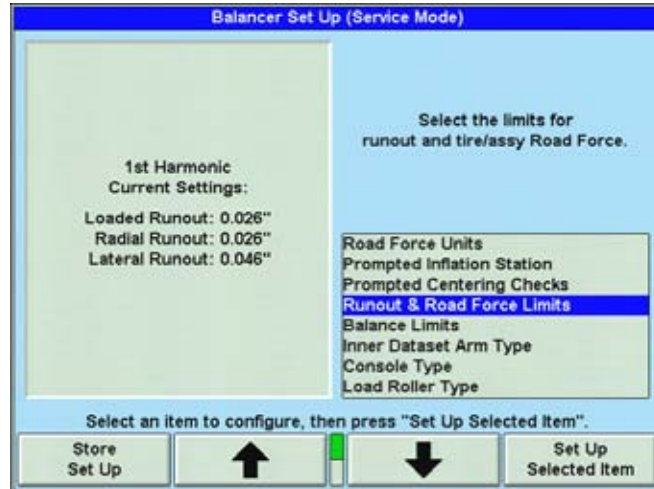

Setting Up the Runout & Road Force™ Limits

Selects the amount of road force and runout needed to exceed limits.

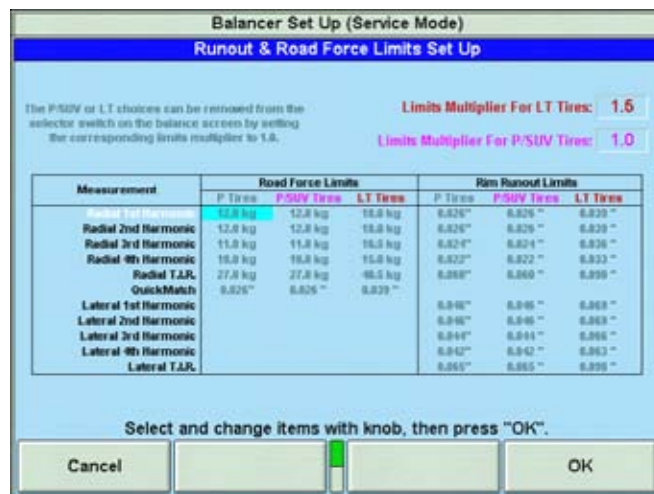

Setting the “P” Limits

The control knob changes the “P” (passenger) tire limits. Push the control knob in to select the measurement limit you desire to change. For more restrictive passenger tire limits, rotate the control knob counterclockwise. For less restrictive passenger tire limits, rotate the control knob clockwise. The light truck and sport utility vehicle limits are based on the limits set for the passenger tires. As the passenger tire limits change, the corresponding “LT” and “P/SUV” limits will also change.

Setting the “P/SUV” Limits

The control knob controls the “P/SUV” (P-Rated tire on a Sport Utility Vehicle) tire multiplier. The multiplier is a figure that is multiplied to the passenger tire limit to obtain the “P/SUV” tire limits. For more restrictive “P/SUV” tire limits, rotate the control knob counter-clockwise. For less restrictive “P/SUV” tire limits, rotate the control knob clockwise. As the multiplier changes, all of the “P/SUV” limits will change corresponding to the current multiplier.

Setting the “LT” Limits

The control knob controls the “LT” (light truck) tire multiplier. The multiplier is a figure that is multiplied to the passenger tire limit to obtain the “LT” tire limits. For more restrictive “LT” tire limits, rotate the control knob counter-clockwise. For less restrictive “LT” tire limits, rotate the control knob clockwise. As the multiplier changes, all of the “LT” limits will change corresponding to the current multiplier.

NOTE: Selecting 1.0 for the multiplier for “LT” or “P/SUV” will disable the “LT” and/or “P/SUV” selection on the balance screens.

Setting the Limits to “Factory Default”

Selecting “Set Factory Defaults” from the second menu tier will return all of the limits to the factory default limits. “P/SUV” defaults to the disabled status as shown above.

Programmed Road Force™ Limits

The GSP9700 road force measurement default limit for P-metric tires is 26 lbs. and for LT tires is 39 lbs. These default limits should be considered only as specified guidelines. They are based on recommendations from many OE vehicle and tire manufacturers and are a conservative average. Limits are used with the GSP9700 as a point of reference so that diagnostic messages guide the operator in decision making processes.

Do not use these limits as the only basis for a tire or wheel replacement. It is up to the manufacturer of the tire or wheel to determine what is defective and what is acceptable if warranty returns become a concern.

Measurement	Road Force Limits			Run Runout Limits		
	P Tires	P/SUV Tires	LT Tires	P Tires	P/SUV Tires	LT Tires
Radial 1st Harmonic	26 lbs.	26 lbs.	39 lbs.	0.040"	0.040"	0.060"
Radial 2nd Harmonic	26 lbs.	26 lbs.	39 lbs.	0.040"	0.040"	0.060"
Radial 3rd Harmonic	22 lbs.	22 lbs.	33 lbs.	0.040"	0.040"	0.060"
Radial 4th Harmonic	18 lbs.	18 lbs.	27 lbs.	0.040"	0.040"	0.060"
Radial T.A.R.	38 lbs.	38 lbs.	57 lbs.	0.010"	0.010"	0.015"
Lateral 1st Harmonic				0.040"	0.040"	0.060"
Lateral 2nd Harmonic				0.040"	0.040"	0.060"
Lateral 3rd Harmonic				0.040"	0.040"	0.060"
Lateral 4th Harmonic				0.040"	0.040"	0.060"
Lateral T.A.R.				0.010"	0.010"	0.015"

Road force limit settings can be programmed into the GSP9700 for passenger tires (P tires), passenger/SUV tires (P/SUV tires), and light truck tires (LT tires).

Every vehicle platform has a different sensitivity level and tolerance to RFV and imbalance. **Known sensitive vehicles may require lower limits to resolve ride disturbance issues.** For example, in some cases, an extremely sensitive vehicle may be affected when the tire/wheel assembly is above 15 lbs. RFM. A setting of 26 lbs. for P Tires and P/SUV Tires is often used as a “middle of the road” limit and does a reasonable job of identifying tires or wheels that may cause a problem. Limits in the Light Truck column are set higher to address the decreased vehicle sensitivity.

Hunter Engineering suggests that advanced users consider setting the default specs to a lower value for “P” setting and use the limit title “P” for sensitive applications. P/SUV limit values may be set to the original 26 lbs. This will give the operator three selections to choose from, P, P/SUV and LT.

The lowest programmable radial 1st harmonic setting is 7 lbs, and the highest programmable radial 1st harmonic setting is 40 lbs.

P, P/SUV, and LT may be selected by using the control knob on the GSP9700.

Setting Up the Balance Limits

Enables and sets limits for both standard wheel balancing and SmartWeight balancing.

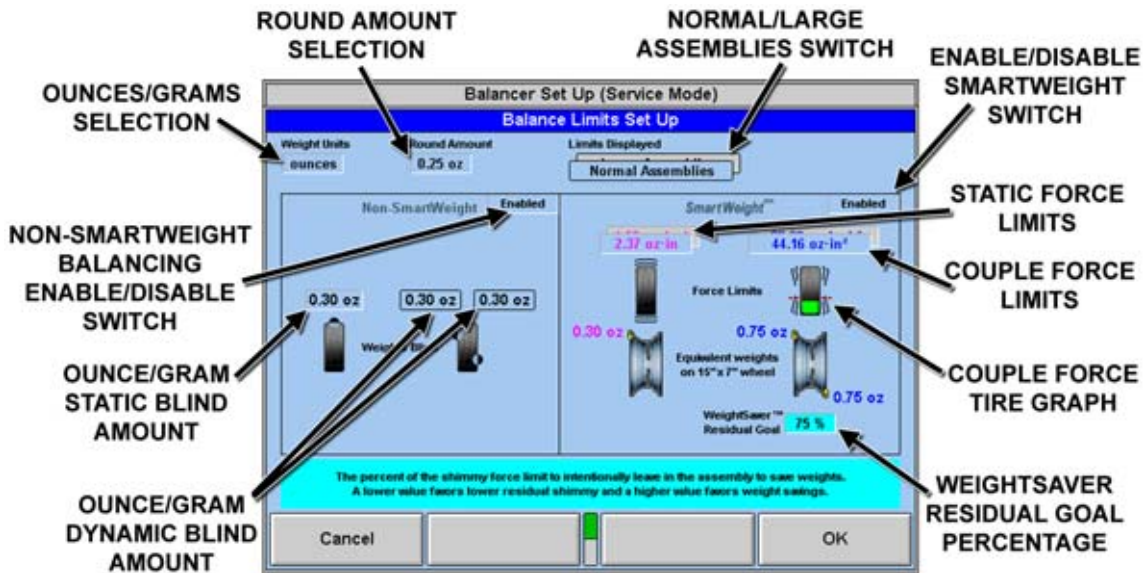

Click on the control knob to change the fields. The current selected field will be highlighted with a description at the bottom of the screen.

Main Selections

Setting Up the Weight Units

Selects the corrective weight units as ounces or grams.

Setting Up the Ounce Round Amount

Selects the amount to which ounce weights are rounded. Ounce Round Amount options include 0.05 ounces, and 0.25 ounces.

Setting Up the Gram Round Amount

Selects the amount to which gram weights are rounded. Gram Round Amount options include 1 gram, and 5 grams.

Setting the Limits Displayed

Limits Displayed switches the SmartWeight settings between Normal Assemblies and Large Assemblies.

Non-SmartWeight Options

Setting Up the Ounce Blind Amount

Selects the amount below which ounce weights show as zero. Ounce Blind Amount options include 0.58 ounces, 0.29 ounces, and 0.15 ounces.

Setting Up the Gram Blind Amount

Selects the amount below which gram weights show as zero. Gram Blind Amount options include 4 grams, 8 grams, and 16 grams.

SmartWeight™ Options - Setting Up the Force Limits

NOTE: The force limits values are set to exact default measurements and should not be changed except by qualified personnel for very specific reasons.

Force Limits can be adjusted for the up and down static force and the side-to-side couple force.

Any changes to the limits can be reset by selecting the “Set Factory Defaults” softkey.

Set
Factory Defaults

WeightSaver™ Residual Goal

WeightSaver™ residual goal is the percent of the shimmy force limit intentionally left in the assembly to save weight. A lower value favors lower residual shimmy and a higher value favors weight savings.

The Residual Goal has a default of 75% of the maximum allowed shimmy force to maximize weight savings.

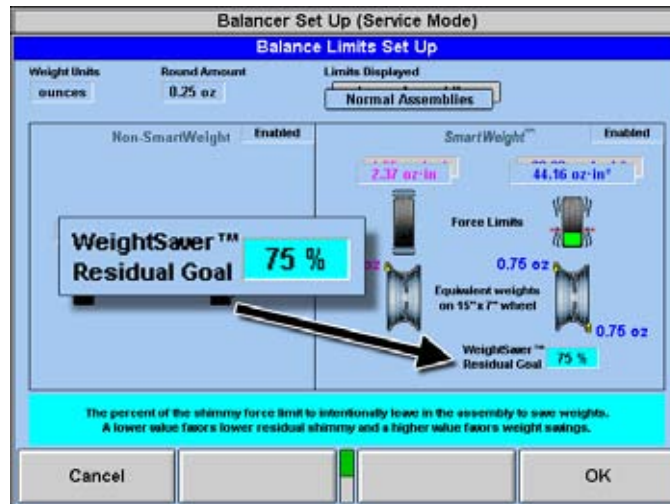

Setting Up the Inner Dataset Arm Type

Selects the appropriate dataset arm. Some units will have a fixed length arm, while others will have an extendable arm for larger diameter rims.

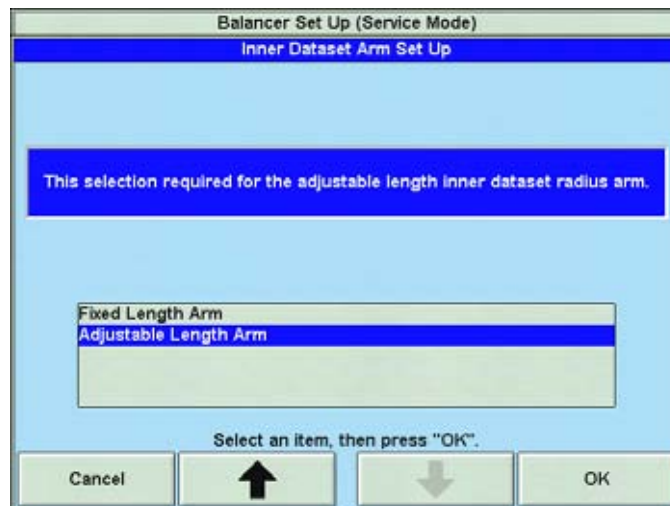

Setting Up the Console Type

Selects the three control knob (Model 9700) or single control knob (Model 9712) balancer console.

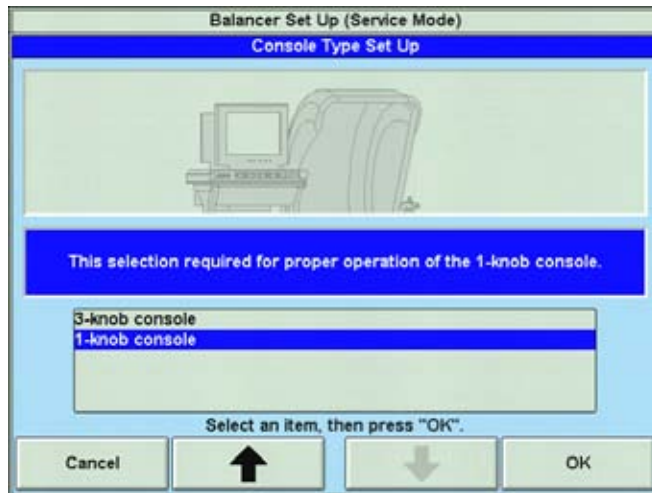

Setting Up the Load Roller Type

Selects the correct load roller type, or disables if there is no load roller present.

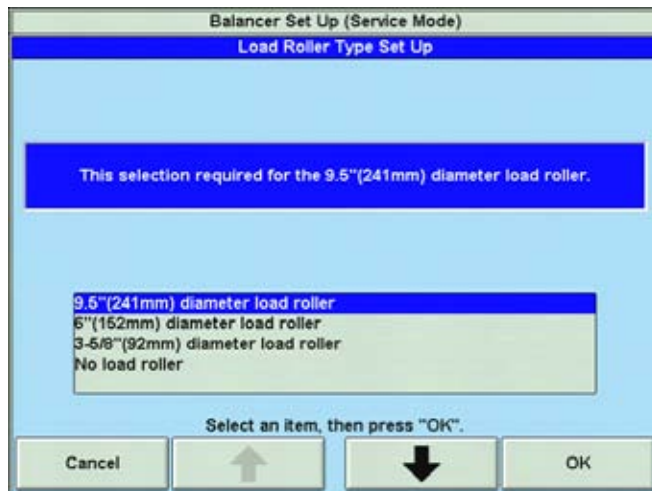

7. Calibration and Maintenance

7.1 Calibration Procedures

The “Calibration” primary screen can be selected by pressing “Calibrate” from the “Logo” screen. The “Calibration Procedures” primary screen contains a list box of calibration procedures. As the procedures are individually highlighted by selecting “↑” or “↓”, the equipment components to be calibrated for each procedure are shown in yellow on the illustrated GSP9700.

Begin calibration procedures by selecting “Begin Procedure.” When finished calibrating, select “Exit.”

Throughout the calibration procedures, “Back Up” can be selected to return to the previous step.

The calibration weight used for calibrating the balancer and the inner dataset arm is stored in one of the weld nuts located on the back of the base assembly or in the weight tray.

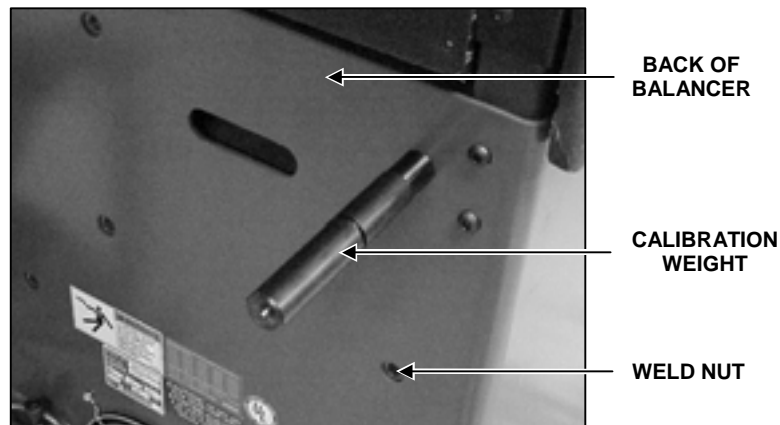

Dataset[®] arm and load roller calibrations require the optional calibration tool, 221-672-1.

Balancer (3 Spin Procedure)

CAUTION: Remove all cones from shaft prior to beginning calibration procedures.

Select “Calibrate” from the “Logo” screen.

Select “Balancer” from the “Calibration Procedures” primary screen.

Select “Begin Procedure.”

Spin 1:



Lower hood and press the green “START” button.

Spin 2:

Lift hood and install calibration weight on the left side of the faceplate in either hole by threading the calibration weight clockwise into the hole.



Rotate calibration weight to the 12:00 position.



Select “Enter 12:00 Position.”

Lower hood and press the green “START” button.

Spin 3:

Lift hood, remove calibration weight, and install calibration weight in the same hole on the opposite side of the faceplate by threading calibration weight clockwise into the hole.



Lower hood and press the green “START” button.

If calibration succeeds, the CRT will display a “Calibration Complete” message.

If calibration fails, such as if the weight was placed incorrectly during the procedure, the GSP9700 will keep previous balancer calibration data.

Inner Dataset[®] Arm (Calibration Tool, 221-672-1, Required)

Select “Calibrate” from the “Logo” screen.

Select “Inner Dataset” from the “Calibration Procedures” primary screen.

Select “Begin Procedure.”

Verify that the inner arm is in the “home” position at the top of the weight tray and is not moving. Tap the foot pedal once or press “Enter Cal Step.”

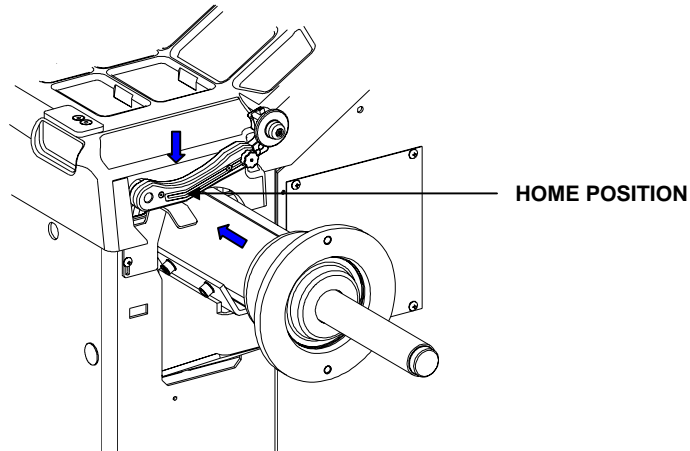

Place the calibration tool on the shaft using the middle spindle shaft slot. Align the center hole of the calibration tool with a calibration weight thread hole, and tighten the calibration weight securing the calibration tool to the hub face as shown below.

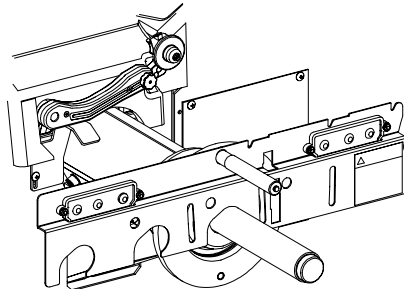

CAUTION: Do NOT operate balancer with calibration tool attached. Remove calibration tool immediately after performing this procedure.

Press “OK” when calibration tool is installed.

Rotate the calibration tool slowly by hand, clockwise until the GSP9700 beeps.

NOTE: You may have to rotate the tool up to 1 1/2 turns.

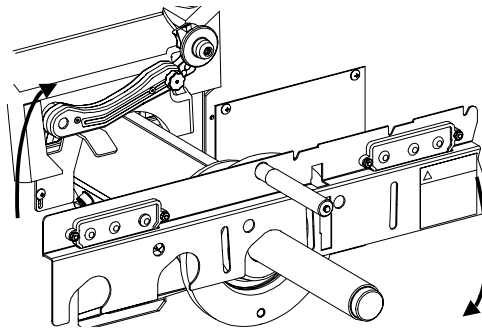

Position the calibration tool parallel to the floor. Tap the foot pedal once or press "OK."

NOTE:

To verify that the tool is parallel to the floor, measure from both ends of the calibration tool to the floor. The measurement will be the same at both ends when the tool is parallel to the floor.

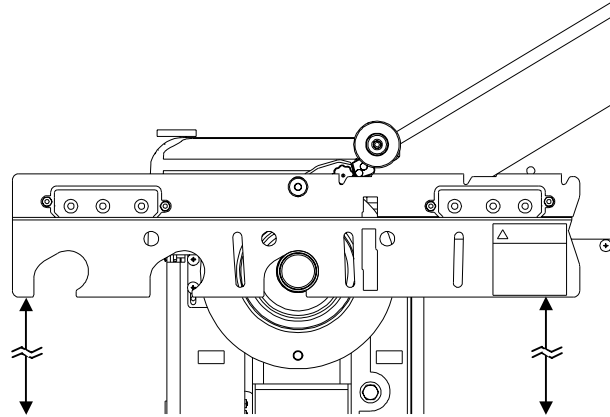

Place the inner Dataset[®] arm at upward position "1." Tap the foot pedal once or press "Enter Cal Step."

**WHEN POSITIONING THE INNER DATASET ARM,
VERIFY THAT THE INDENT OF THE ARM IS
CENTERED ON THE BUTTON FOR EACH POSITION.**

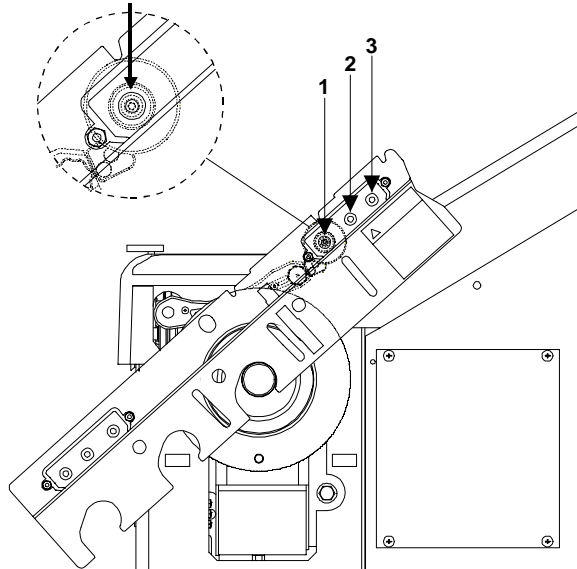

NOTE:

If the inner Dataset[®] arm is unstable while entering any step, a long, high-pitched tone will sound to advise that the step has **NOT** been entered. Stabilize the arm and re-enter the step.

Place the inner Dataset[®] arm at upward position "2." Tap the foot pedal once or press "Enter Cal Step."

Place the inner Dataset[®] arm at upward position "3." Tap the foot pedal once or press "Enter Cal Step."

Place the inner Dataset[®] arm at downward position “4.” Tap the foot pedal once or press “Enter Cal Step.”

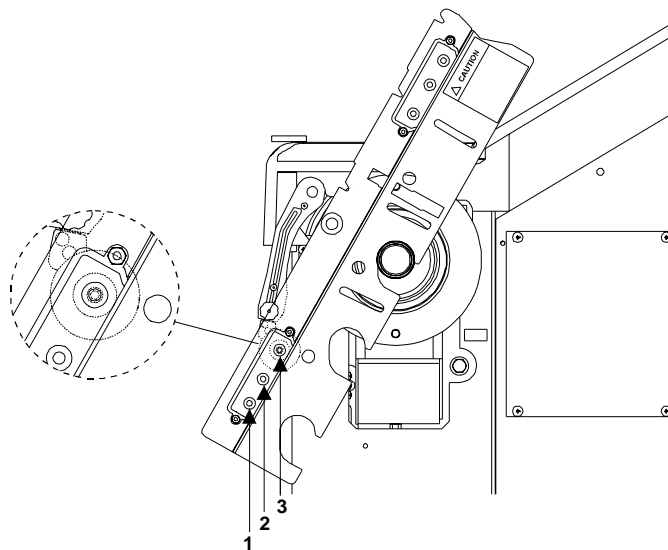

Place the inner Dataset[®] arm at downward position “5.” Tap the foot pedal once or press “Enter Cal Step.”

Place the inner Dataset[®] arm at downward position “6.” Tap the foot pedal once or press “Enter Cal Step.”

Remove the calibration weight from the calibration tool and return it to its storage position.

Position the calibration tool parallel to the spindle shaft on the hub using the hub mounting slot as shown.

Place the inner Dataset[®] arm at the position “7.” Tap the foot pedal once or press “Enter Cal Step.”

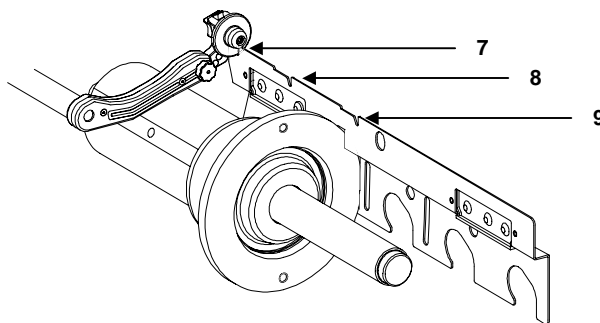

Place the inner Dataset[®] arm at the position “8.” Tap the foot pedal once or press “Enter Cal Step.”

Place the inner Dataset[®] arm at the position “9.” Tap the foot pedal once or press “Enter Cal Step.”

Inner Dataset[®] arm calibration is complete.

Outer Dataset[®] Arm (Calibration Tool, 221-672-1, Required)

Select “Calibrate” from the “Logo” screen.

Select “Outer Dataset” from the “Calibration Procedures” primary screen.

Select “Begin Procedure.”

With the hood in the raised position, verify that the outer arm is in the “home” position and that the arm and hood are not moving. Tap the foot pedal once or press “Enter Cal Step.”

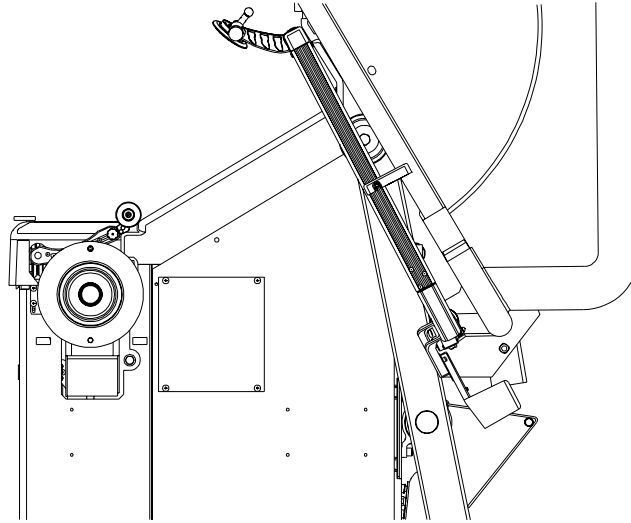

Place the calibration tool on the spindle shaft using the spindle shaft slot closest to the end of the calibration tool and hold in an upright position, flat against the hub.

NOTE: The calibration tool should be in full contact with the hub face, but will allow a gap to exist between the tool and the hub face.

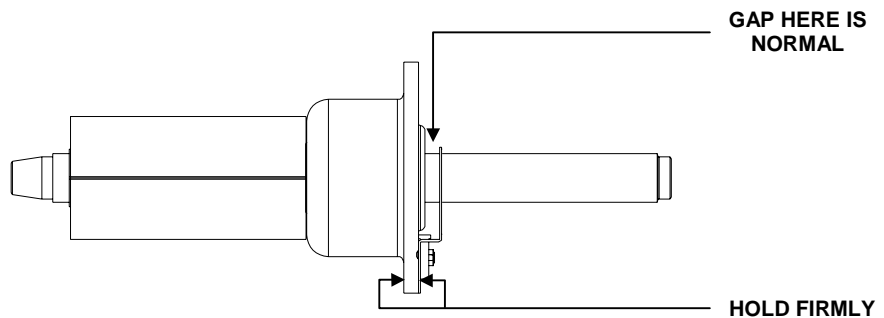
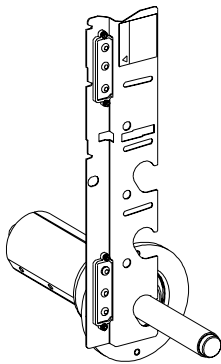

Place the outer Dataset® arm at position “1.” Tap the foot pedal once or press “Enter Cal Step.”

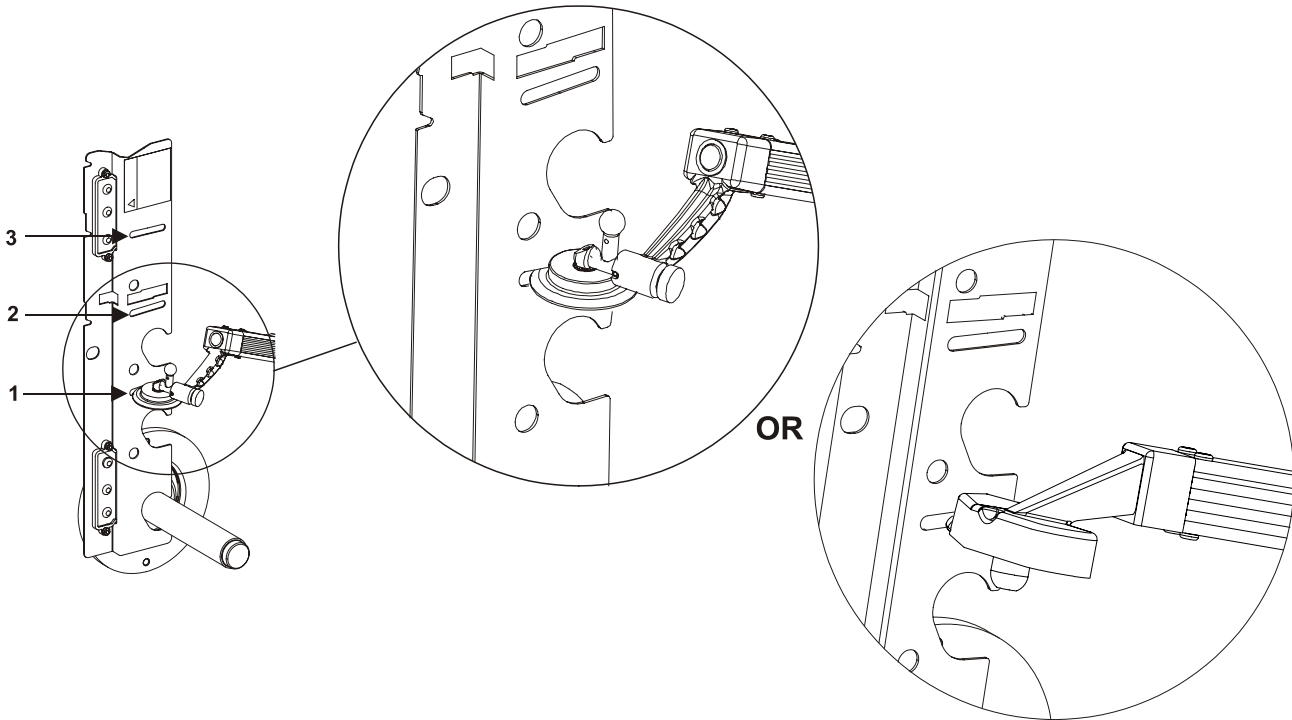

NOTE: If the outer Dataset® arm is unstable while entering any step, a long, high-pitched tone will sound to advise that the step has NOT been entered. Stabilize the arm and re-enter the step.

Place the outer Dataset® arm at position “2.” Tap the foot pedal once or press “Enter Cal Step.”

Place the outer Dataset® arm at position “3.” Tap the foot pedal once or press “Enter Cal Step.”

Loosen the outer Dataset® arm locking screw by turning it counterclockwise and rotate the outer arm ball into the downward position by pulling the locator pin out of the locator slot and rotating the ball 180 degrees. Secure the locking screw.

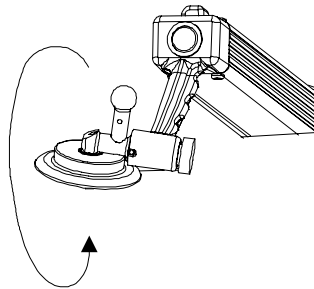

Place the calibration tool on the hub using the hub mounting slot as shown.

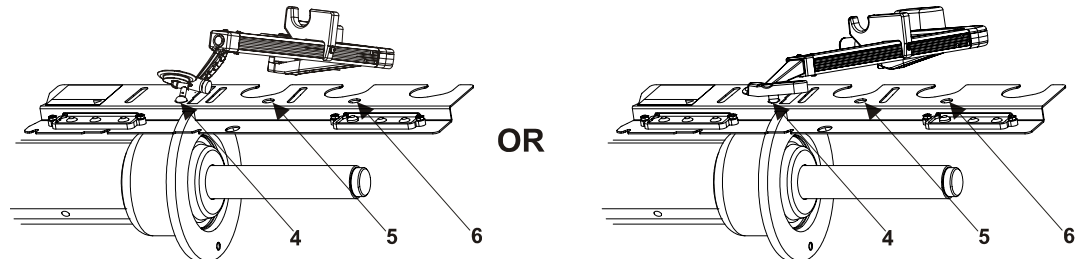

Place the outer Dataset[®] arm ball in the hole for position “4.” Tap the foot pedal once or press “Enter Cal Step.”

Place the outer Dataset[®] arm at position “5.” Tap the foot pedal once or press “Enter Cal Step.”

Place the outer Dataset[®] arm at position “6.” Tap the foot pedal once or press “Enter Cal Step.”

Rotate the outer arm ball back to the upward position.

Outer Dataset[®] arm calibration is complete.

Load Roller (Calibration Tool, 221-672-1, Required)

Select “Calibrate” from the “Logo” screen.

Select “Load Roller” from the “Calibration Procedures” primary screen.

Select “Begin Procedure.”

Verify that the load roller is in the “home” position and is not moving. Tap the foot pedal once or press “Enter Cal Step.”

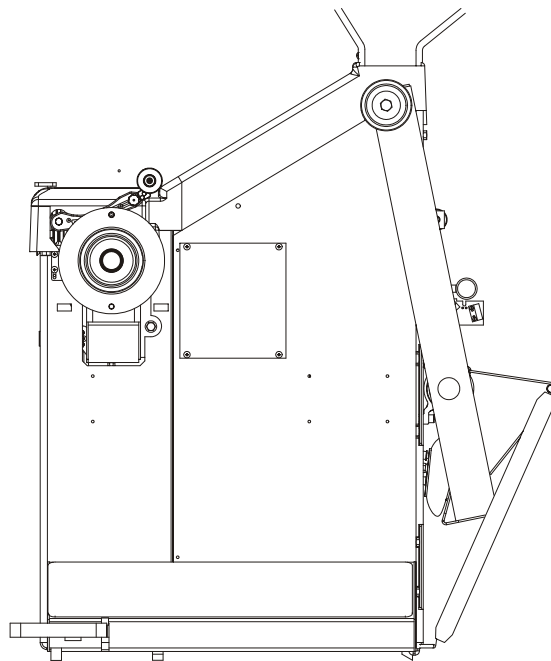

Disconnect the air supply and load roller return spring.

⚠ CAUTION: Failure to disconnect the air supply may result in personal injury.

Position the calibration tool on the spindle shaft using the spindle shaft slot closest to the end of the tool. Place load roller at position “1.” Tap the foot pedal once or press “Enter Cal Step.”

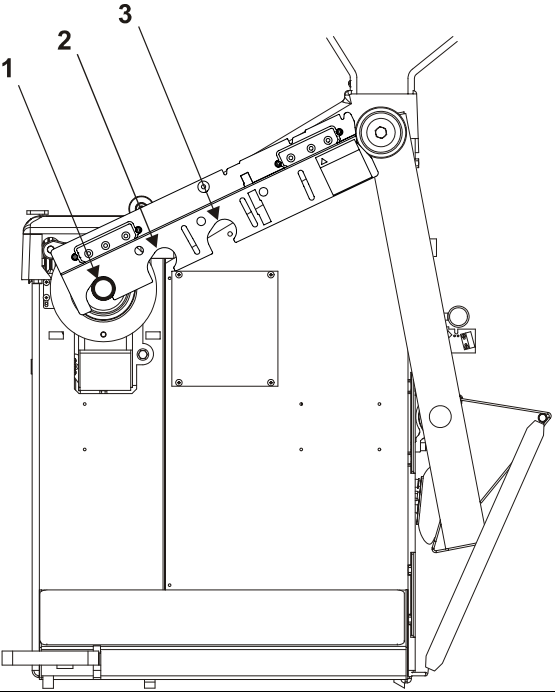

NOTE: If the load roller is unstable while entering any step, a long, high-pitched tone will sound to advise you that the step has NOT been entered. You must stabilize the load roller and re-enter the step.

Position the calibration tool on the spindle shaft using the middle spindle shaft slot. Place load roller at position “2.” Tap the foot pedal once or press “Enter Cal Step.”

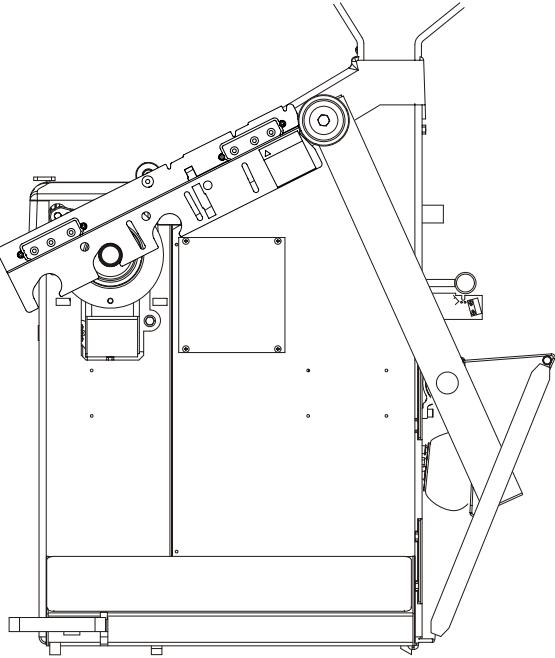

Position the calibration tool on the spindle shaft using the spindle shaft slot closest to the center of the tool. Place load roller at position “3.” Tap the foot pedal once or press “Enter Cal Step.”

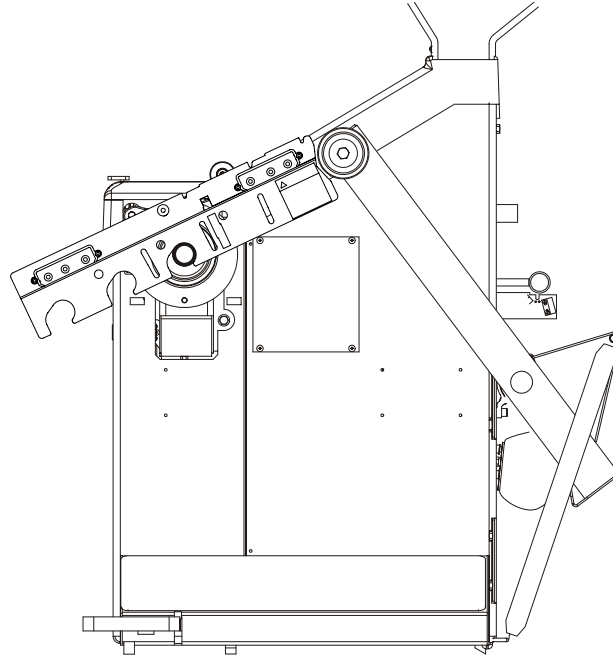

Reconnect the load roller return spring.

Reconnect the air supply.

CAUTION: To prevent injury, verify that the load roller return spring is reconnected **PRIOR** to reconnecting the air supply.

Load roller calibration is complete.

Servo-Stop

The calibration of the Servo-Stop measures and stores characteristics of the motor drive and line conditions to allow accurate operation of the automatic wheel-positioning feature and proper speed control.

To calibrate the Servo-Stop:

Mount a wheel assembly of average weight onto the GSP9700.

Lower the hood and press the green “START” button.

Wait for the motor to rotate the assembly at a very low speed. The motor will reverse directions twice.

Servo-Stop calibration is complete.

Quick Calibration Check Procedure

Quick Cal™ Check can be performed from the “Logo” primary screen immediately after initial boot-up or after a reset is performed. It provides a quick way to check the calibration of the force sensors used for balancing.

NOTE:	Quick Cal™ Check does not check the calibration of the Servo-Stop, dataset arms, or load roller.
--------------	--

Install the calibration weight on either side of the hub faceplate using either hole.

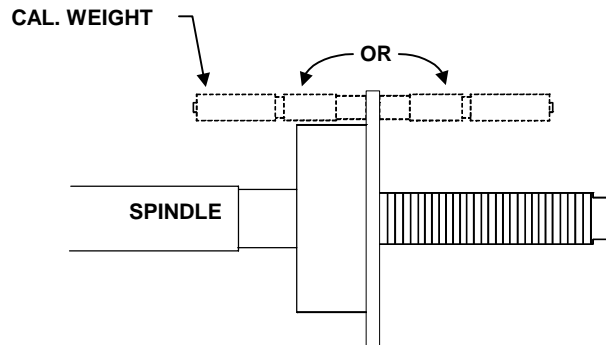

From the “Logo” primary screen, close the hood and press “Start.”

The screen will ask you to verify that you want to perform a Quick Cal-Check Spin.

Press “Start” again for the calibration-check spin.

The display screen will read “Calibration Ready,” indicating the balancer is calibrated and ready to use.

NOTE:	If “Calibration Out” occurs, the balancer needs to be recalibrated. Refer to “Balancer (3 Spin Procedure),” page 117.
--------------	---

Check angle accuracy by verifying that when the weight location indicator is rotated to TDC (12 o’clock position), the calibration weight is at TDC (12 o’clock position). If cal weight is in a position other than TDC, perform calibration procedure.

The Quick Cal™ Check is complete.

7.2 Diagnostic Procedures

The “Diagnostics” primary screen can be selected by pressing “Diagnostics” from the “Logo” screen. The “Diagnostics” primary screen contains a list box of diagnostic procedures. As the procedures are individually highlighted by selecting “↑” or “↓,” the equipment components for each diagnostic procedure are shown in yellow on the illustrated GSP9700.

Begin diagnostic procedures by selecting “Begin Selected Test.” To exit a diagnostic procedure, select “End This Test.”

Most of the diagnostic data is available for the sole purpose of conveying information to your Hunter Service Representative. Your service representative may request information from these screens to diagnose service concerns. The ability to convey diagnostic data to the representative prior to servicing the GSP9700 will expedite service to your equipment.

You may also perform diagnostic tests to diagnose concerns yourself. For example, “Keys and Switches” can be tested to verify the proper operation of each key and switch.

Force Sensors

Tests both force sensors and displays samples from the last spin.

Rotary Encoders

Tests spindle and knob encoders. Displayed data can be changed by turning the spindle and control knob verifying that they are in working order.

Keys and Switches

Tests keypad and switches. Each working keypad and switch will beep upon closure to verify that it is in working order.

Data Acquisition Circuits

Tests Data Acquisition Circuits (displays real-time samples as acquired by main PC Board electronics).

Dataset[®] Arm Sensors

Tests inner and outer Dataset[®] arm sensors and displays samples from the last spin.

Loaded Runout Sensor

Tests loaded runout sensor and displays samples from the last spin.

7.3 Printing

A "Print" softkey is offered on some screens. Pressing the "Print" key will activate the printer and print the information shown on the current screen.

Lights on the front panel of the printer indicate printer status. The buttons on the front panel of the printer control the functions of the printer.

POWER light – indicates the printer power is on.

ALARM light – lights when the printer is out of paper. The alarm also lights should the printhead become jammed or stopped.

SELECT light – lights when printer is in select mode and must be on for printer to be on-line with the computer.

SELECT button – will place printer in de-select mode and stop communication between the printer and the system. To return to the select mode, press again. It will also stop the self test at power up.

PITCH (10, 12, 17 lights) – indicates the number of characters per inch to be printed. Default position is 10. Selection is made using the PITCH button.

MODE (NLQ, UTILITY, HSD lights) – indicates the quality of the printer output as near letter quality (NLQ), utility, or high speed draft (HSD). Default position is UTILITY. Selection is made using the MODE button.

TOF SET button – will set the "Top of Form" (the first printing line) at the current location of the printhead when printer is de-selected.

FORM FEED button – will advance the paper to the next top of form.

LINE FEED button – will advance the paper one line

Changing Ribbon Cartridge (P/N 162-42-2):

Remove the access cover by lifting it off.
Slide the printhead to the middle of the printer away from the rollers on the bail.
Grasp the cartridge on both sides and lift up.
Snap the new cartridge on the printhead plate. (Tilt the back of the cartridge so it slides into the plate, lower the top of the cartridge over the printhead aligning the tabs on either side with the inserts on the printhead plate.)

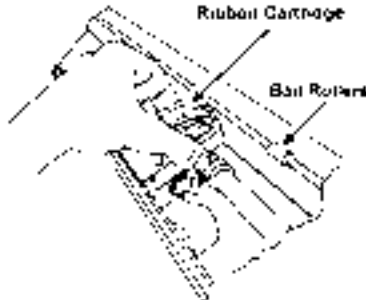

Reinstall the access cover.

Bottom Feed Paper Loading

Turn the printer "OFF."
Remove printer paper from packaging and place into recess in printer drawer.
Feed paper through bottom of printer and place printer into drawer.
Remove the access cover and lift the bail.
Open the paper lever.
Insert first sheet of paper through the paper separator and into the paper guides.
Continue to slide paper until it appears in front of the roller.
Align the holes of the paper with the corresponding pins of the adjustable pin feeds.
Lower the bail.
Use the roller knob to advance the paper to the first printing line location.
Replace the access cover and turn the printer on.

NOTE:	After changing the ribbon cartridge, loading paper, or clearing a jam, turn the printer "OFF" and then back "ON."
-------	---

7.4 Cleaning the Console

When cleaning the console, use window cleaning solution to wipe off the display console and cabinet. Do not spray window cleaning solution directly onto control panel or CRT. Power should be "OFF" prior to cleaning the CRT.

 WARNING: Exposing the balancer to water either by hose, bucket, or weather may cause risk of electrical shock to operator or bystanders and will damage the electrical system. Place, store, and operate the balancer only in a dry, sheltered location.

7.5 Spindle Hub Face and Shaft Maintenance

Keep the shaft and wing nut threads clean and lubricated. Lubricate the shaft without contaminating the hub face. Select “Clean Spindle Threads” from the “Balance” primary screen. Run the edge of a rag between the threads while the spindle is slowly turned by the motor drive. If any signs of dirt or debris appear on the spindle threads, the spindle should be cleaned immediately prior to mounting a wheel.



CAUTION: Failure to clean spindle properly will result in a loss of clamping force. Due to the force applied to the wheel by the load roller, it is critical to maintain optimum clamping force.

Lubricate the shaft with a coating of light lubricant with Teflon[®] such as Super Lube[®] by Loctite after cleaning. Do not lubricate the spindle hub face mounting surface. This could cause slipping between the wheel and the hub face. Keep the hub face mounting surface clean and dry.

7.6 Mounting Cone Maintenance

Keep the mounting cones clean and lubricated. Lubricate with a coating of light lubricant with Teflon[®] such as Super Lube[®] by Loctite.

Do not use cones in any way that is not described in this operation manual. This could cause damage to the mounting cone and not allow for proper mounting of the wheel.

8. Theory of Operation

8.1 Harmonic Vibrations

A vibration in a tire and rim assembly can be caused by:

- Imbalance
- Change in Sidewall Stiffness (Force Variation)
- Rim Bent/Out-of-Round
- Tire Out-of-Round
- Wheel to Axle Mounting Error*
- Brake Component Wear or Failure*
- Drivetrain or Engine Component Wear or Failure*
- Vehicle Component Characteristics*
- Combination of Some or All Factors

*Factors not detected by the GSP9700 Series Road Force Measurement System.

A vibration that occurs one time for every revolution is defined as a first harmonic vibration:

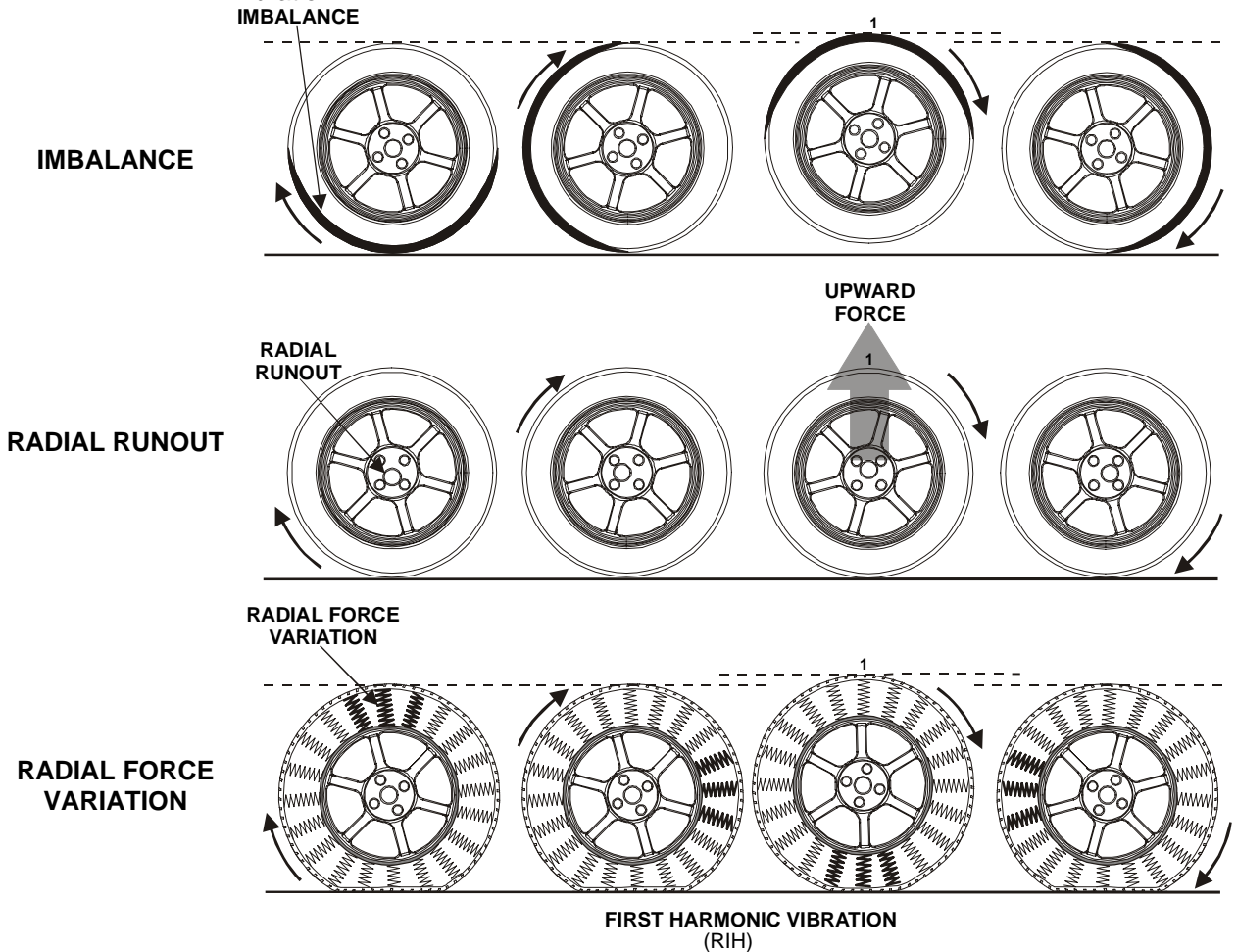

During ForceMatching, the first harmonic vibration of the tire is matched opposite of the first harmonic vibration of the rim to decrease the first harmonic vibration of the assembly. This reduces the vibration felt inside of the vehicle.

A vibration that occurs twice for every revolution is defined as a second harmonic vibration. Because there are two vibrations per revolution, the second harmonic vibration occurs at twice the frequency of a first harmonic vibration:

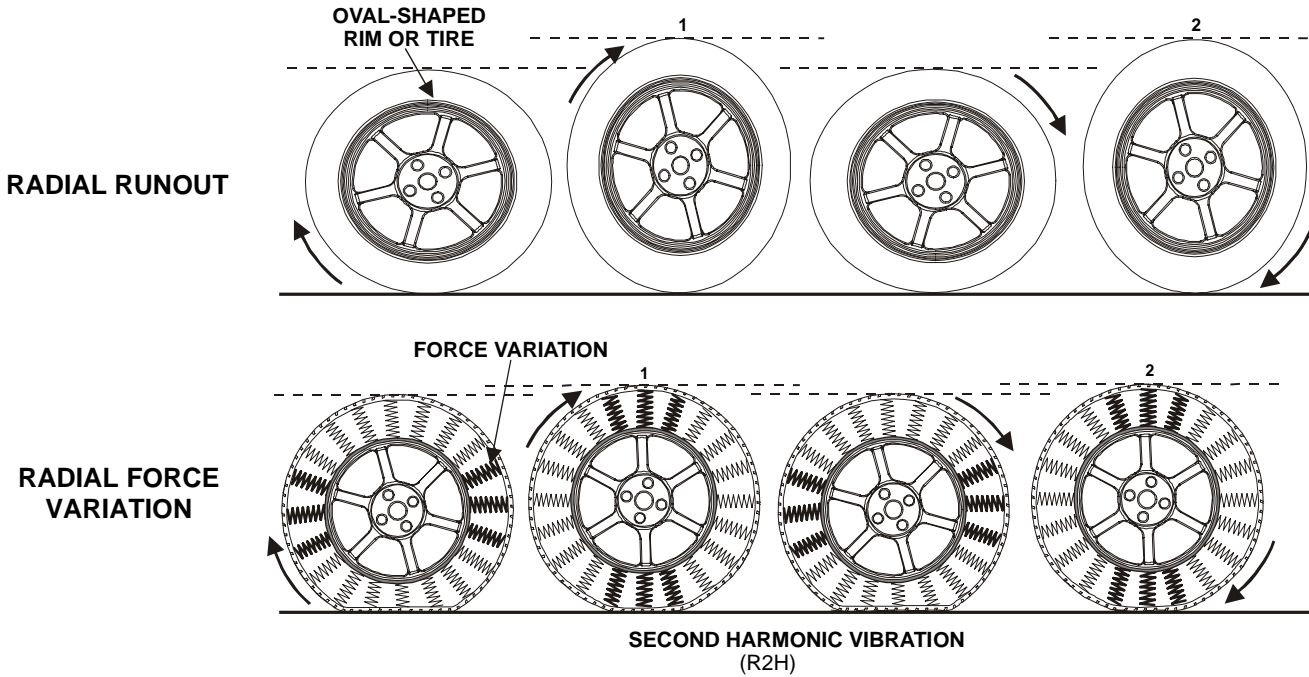

Multiple harmonic vibrations may also occur. For instance, the third order vibration causes a three times per revolution vibration:

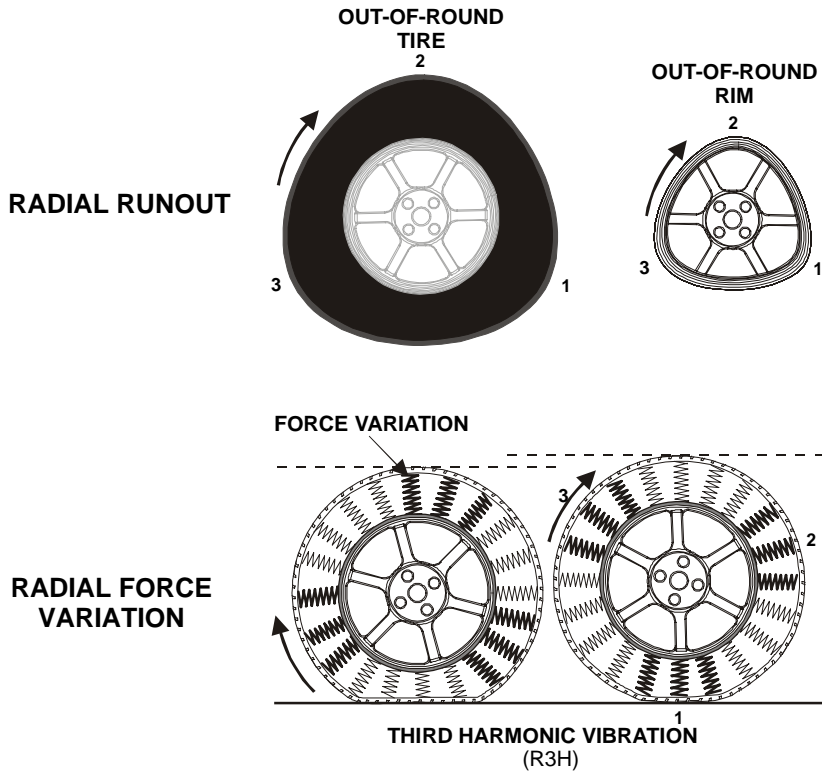

Multiple harmonic vibrations may occur at any harmonic factor, dependant only upon the number of vibration components in each revolution.

8.2 Road Force™ Measurement

Road Force™ Measurement is new to the automotive service industry. It emulates tire uniformity measurement, which has been measured for years in assembly plants and manufacturing facilities. Road Force™ Measurement can be used to locate and solve uniformity related tire and wheel vibrations. Tire/wheel assembly uniformity can only be measured under load.

With recent changes in vehicle sensitivity and increasing ride quality expectations, wheel balancing alone may not be sufficient to eliminate the tire/wheel assembly as a vibration source. The GSP9700 Series Road Force Measurement System is a measuring and diagnostic tool and automatically detects possible vibration sources in a tire/wheel assembly that cannot be identified by traditional balancing methods. As a diagnostic tool, the GSP9700 reduces the unnecessary replacement of tires and wheels, significantly reduces troubleshooting time, and offers improved ride quality.

The load roller on the GSP9700 performs a computer simulated “road test.” It measures the tire/wheel assembly to determine how “round” the assembly is when rolling under a load. If a tire were not exposed to the road surface, then balance would be more than sufficient. However, not all tires roll round under a load. For example, an egg-shaped tire/wheel assembly can be balanced about its axis, but an egg-shaped tire/wheel loaded against a surface would not give a smooth ride.

The GSP9700 reduces diagnostic time by identifying vibrations that would not be detected by the normal balancing procedure. Road Force™ Measurement also detects loaded and free measured runout, force variation of the tire, and balancer mounting error, allowing superior quality balance of the entire wheel assembly.

Road Force™ Measurement is a measurement of the wheel assembly as would be found from an actual road test of a vehicle. The GSP9700 is equipped with a load roller to take the Road Force™ Measurement. The load roller places up to 1400 pounds of force on the spinning tire, and then automatically withdraws from the wheel.

Road Force™ Measurement data may be viewed from the “Show Runout & Force Variation” popup screen.

Force Variation

Force variation is a correctable symptom of the tire and/or rim being out of round, the changes in stiffness of the sidewall and footprint of the tire when a load is placed against it, or a combination of both factors acting on the assembly. **Force variation can cause a vibration, although the unloaded runout of the tire and rim measure perfectly round and the assembly is balanced.**

NOTE:	It is important that the air pressure of the tire is set to specifications prior to the Road Force™ Measurement. Incorrect tire pressure will affect the results.
-------	---

Tire Radial Force Variation (Uniformity)

To understand the effects of radial force variation, imagine the tire as a collection of springs between the rim and the tire tread. If the “springs” are not of uniform stiffness, a varied force is exerted on the axle as the tire rotates and flexes. This creates a vibration in the vehicle.

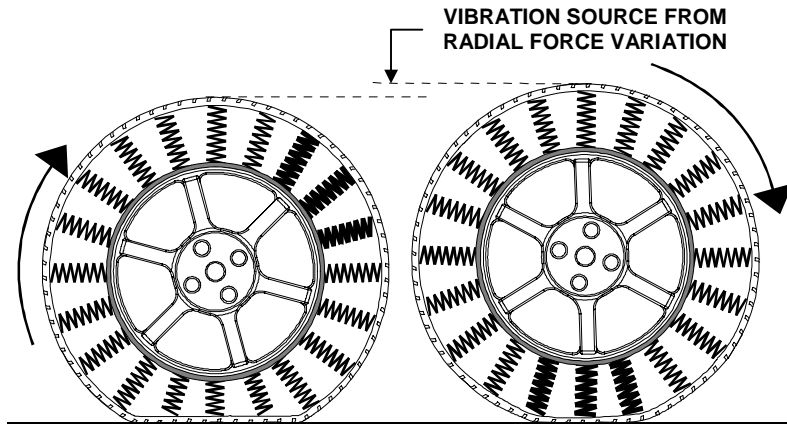

With the increasing need for low tire uniformity values to minimize vibration complaints, more tire companies are grinding or cutting tires during the manufacturing process. As a result, free runout measurement is no longer an accurate indicator of how the tire assembly will perform when rolling under load. Free run out measurement should not be used as a guide to determine the tires contribution to the ride disturbance complaint.

The GSP9700 takes a measurement of the wheel assembly's radial force variation and displays the results. If the GSP9700 perceives a problem with the force variation, it will prompt you to measure rim runout. Refer to “Rim Runout Measurements,” page 54. When the rim runout data is entered, the GSP9700 extracts and displays the first harmonic force variation contribution of the tire and of the rim. Refer to “Harmonic Vibrations,” page 131. The GSP9700 allows the first harmonic of the tire to be matched opposite of the first harmonic of the rim to decrease the first harmonic vibration. The tire and/or rim may need to be replaced or ForceMatched prior to balancing. Refer to “ForceMatching,” page 61.

8.3 Radial Force Variation (RFV)

Radial force variation is a term describing the measurement of the tire uniformity under load, measuring the variation (up and down) of the load acting on the vehicle spindle (SAE practice J332).

All tires have some non-uniformity in the sidewall and/or footprint due to variables in the manufacturing process. Tire uniformity measurement values can be affected by rim width, rim condition, and/or tire mounting variables. Unlike balancing, there is often a small amount of RFV remaining in the tire/wheel assembly after ForceMatching and this is generally acceptable.

8.4 Radial Force Variation vs. Unloaded Run Out

In the manufacturing community, tire uniformity is called radial force variation. The uniformity of most tires manufactured today is measured with a machine in accordance to SAE practice J332. This practice is widely used in the tire industry and describes tire testing equipment and procedures used to measure radial force variation of the tire. This practice stresses the importance of measuring force variation while the tire is under load and does not acknowledge unloaded runout measurement, for use in tire vibration testing.

Many tire assembly plants have large production lines to measure loaded tire force variation. Tires, which do not meet uniformity specifications, may be brought into specification through additional manufacturer's procedures called force grinding. Force grinding is done to improve radial force variation by removing small areas of rubber from the sides and footprint of the tread. Force grinding may not improve (and in some cases may increase) the unloaded runout measurement.

A tire with large amounts of unloaded radial runout may be vibration free while a tire with low unloaded radial runout may cause a ride disturbance. In many cases, tire companies will forego unloaded runout measurement since this information is not as valuable as tire force variation when it comes to analyzing the causes of tire ride disturbances.

In the past, when trying to resolve tire/wheel vibration concerns, service facilities were unable to measure tire force variation. The size and expense of the factory machines were cost prohibitive. In order to compensate for this lack of field service technology, many automotive and tire manufacturers have published service limits for unloaded runout in the tire/wheel assembly.

A standard industry practice has been to measure unloaded runout in the center of the tire tread using a relatively inexpensive gauge. However, this measurement has little relationship to the actual amount of ride disturbance felt in the vehicle. For example, a set of springs may have an unloaded height measurement of equal length, yet when compressed may create different forces at the same compressed height.

8.5 Road Force™ Vibration Placed into Perspective

In the past, most tire/wheel assembly vibration was considered balance related. Because of this, tire service professionals tend to relate tire/wheel vibration in terms of balance weight. Road Force™ Measurement will be best understood when related to the amount of balance weight required to cause a similar vibration in a wheel that rolls round under a load. In other words, "How much Road Force Measurement creates a similar vibration caused by tire imbalance?"

Most tire service professionals and factory service manuals agree that residual static imbalance should not exceed 0.30 oz. on average size wheels and 0.60 oz. on larger light duty truck wheels.

Radial Force is determined by measuring loaded radial runout and tire stiffness. On an average passenger car tire/wheel assembly (1000psi spring rate), one thousandth of an inch (0.001") of loaded radial runout is equivalent to approximately one pound of Road Force™ Measurement.

Tests on a Chevrolet Lumina were performed using a chassis dynamometer in a Detroit test lab. The purpose of the test was to determine how much balance weight would be required to produce the same magnitude of force as a measured amount of loaded radial runout.

The tests were performed with the vehicle running at different speeds. The first test was at 50 miles per hour and the second test at 70 miles per hour.

At 50 MPH:

A measured 0.030" (about 30 pounds of road force) of loaded radial runout caused the same amount of vibration as 1.5 ounces (42 grams) of wheel imbalance at 50 mph. This is **5 times greater** than the 0.30 (1/4) ounce imbalance limit.

At 70 MPH:

A measured 0.030" (about 30 pounds of road force) of loaded radial runout caused the same amount of vibration as 0.75 ounces (21 grams) of wheel imbalance at 70 mph. This is **1 1/2 times greater** than the 0.30 (1/4) ounce imbalance limit.

8.6 StraightTrak[®] Lateral Force Measurement System

StraightTrak[®] Lateral Force Measurement

Although a vehicle's suspension checks out to be acceptable, the tire pressure is correct, the vehicle suspension is properly aligned, and the tire/wheel assembly is perfectly round when rolling and balanced, the vehicle may still tend to pull or drift from a straight line. Frequently the cause of this pull is excessive difference in lateral force between the tires on the steer axle.

This **optional** feature measures the lateral forces of the tire/wheel assembly and suggests placement of each tire/wheel assembly (relative to the other tire/wheel assemblies) on the vehicle so that vehicle pull due to tire lateral forces can be minimized or eliminated.

<p>NOTE: StraightTrak[®] requires Lateral Force Measurement hardware and Version 3.0 software or newer.</p>
--

Tire Pull Measurement and Correction

Even after tire/wheel assemblies have been balanced, correct inflation has been set, and suspension has been properly aligned, a vehicle may still pull from a straight line. The cause of this pull can be due to excessive difference in lateral tire force between the two tires on the steer axle.

The optional StraightTrak[®] Lateral Force Measurement (LFM) feature of the GSP9700 is configured to utilize lateral force measurement information taken from a set of vehicle tires. It provides suggested placements for the individual tires about the vehicle, such that the net tire pull between the two tires on the steer axle are minimized to improve or optimize the effects on vehicle handling.

When using StraightTrak[®] LFM, the basic machine cycle is the same as it has been for the standard GSP9700, except that several additional tire revolutions have been added to the end of the cycle so that lateral force measurements can be taken. The only additional procedure necessary by the operator is to number, or "tag," the tire assembly for identification and placement when balancing is completed.

The GSP9700 will provide the operator with suggested placement of the tire/wheel assemblies so that the net tire pull (lateral force) is minimized. There are up to twelve alternate placement choices to offset other vehicle-related causes.

To maximize the effectiveness of StraightTrak[®] LFM, all other known sources of pull should first be reduced as much as possible. Improper and/or uneven tire inflation, excessive alignment angle variation side to side, and suspension/steering torque can also directly add to the potential for a vehicle to pull, and can even increase the rate at which the lateral forces in tires change over time.

Previously, diagnosis of such pull conditions involved the slow trial and error process of swapping tire/wheel assembly placements in a certain order, in the attempt of finding the least offensive placement. The amount of time involved in such a process

is unpredictable and unfavorable for shops charging flat rates and for customers paying for labor by the hour.

While the StraightTrak[®] function should not replace fundamental diagnostic procedures, such as visual inspection of tread wear, inspection for brake drag, measurement of tire pressure and ride height, suspension check, alignment, and test driving, StraightTrak[®] has the potential to dramatically reduce the number of trial configurations and test drives.

What can be accomplished with StraightTrak[®] LFM?

- Elimination or reduction of tire related drift/pull
- Superior ride quality from increased vehicle straight-ahead stability
- Prevention of problems or comebacks after rotations
- Enhancement of steering stability and reduction in wandering
- Reduction of driver fatigue due to pull

When should StraightTrak[®] LFM be used?

- Tire mounting and balancing processes
- Tire rotations
- Alignment services

How is StraightTrak[®] LFM used?

Determine minimum lateral force offset on a steer axle to reduce/eliminate tire related pull conditions. The “least net tire pull” in most cases will yield the best results.

Diagnose residual pull symptoms with a road test. (In this case, the original placement of the tires and the associated tire net pull is important to use in order to determine the amount of offset on the new placement.) The “least net tire pull” placement may not be the best choice and in some cases “alternate placement” choices can be used to counteract other variables causing the vehicle to pull. Refer to “Show Least Pull,” page 76.

Theory

Automotive and light truck tires produce a lateral (or axial) force when rolling on a flat, smooth road. Lateral force is defined as the amount of directional side force generated as the tire/wheel assembly rotates. The net sum difference in the lateral force between the two front steer tires may cause a vehicle to steer away from a straight line. Sources of lateral forces include tire conicity, ply steer, and other forces known together as **Total Lateral Force**. Traditional wheel balancers and static wheel alignment measuring systems cannot measure conditions caused by tire lateral forces. The automotive service industry has long been aware of tire-related vehicle lateral force conditions; however, no quantifiable method for diagnosis has existed for the service shop.

With the StraightTrak[®] Lateral Force Measurement (LFM) feature, the Hunter GSP9700 Series Road Force Measurement System can measure the primary lateral forces generated by a rolling tire/wheel assembly. Using the load roller, it applies radial loads of up to 1400 pounds to the tire. The corresponding lateral forces produced between the tire and load roller are then measured. By rotating the tire/wheel assembly both clockwise and counter-clockwise, the system can calculate conicity values for a set of tires and then display net results from twelve possible tire combinations on the steer axle. With this information, technicians can place tires to minimize or eliminate pull. The Lateral Force measurement is automatically performed during the normal Road Force™ measurement sequence.

Conicity

Conicity is the primary lateral tire force measurement that contributes to vehicle pull problems. When combined with other tire and vehicle variables, the vehicle may drive off line if the steering wheel is released. The steering wheel may be straight when the vehicle travels straight, but the driver must exert a force to the wheel to maintain the straight-ahead stability. This can result in driver annoyance, fatigue, and safety related concerns. Conicity is sometimes called "tire camber" and it affects the vehicle in a similar manner to suspension alignment angles.

Conicity forces will usually not cause a pull or drift issue when tires of similar values are mounted on the same vehicle. It is the net difference between the two tires on the steering axle that make the difference between a vehicle that rolls straight and one that drifts or pulls.

Conicity in tires may be caused when the radial belts vary from exact placement in the center of the tire carcass during construction. The sidewall to which the belts are placed closer will be stiffer (and thus taller) than the opposite side. This produces a cone shaped tire when loaded.

Conicity in tires will also be affected by tire wear, therefore conicity values typically change during a tire's life.

Plysteer

Plysteer induces a dog-tracking attitude of the vehicle. When large net plysteer variations on an axle are encountered, the steering wheel will change position and possibly end up crooked to maintain a straight direction of travel. The vehicle, however, will not necessarily drift or change lanes when the steering wheel is released. The driver at the steering wheel exerts no correction force. The GSP9700 measures, but does not display and correct for plysteer.

Net Tire Pull

Net Tire Pull is the measurement displayed by the GSP9700 to allow the operator to determine the best tire placement about the vehicle. It is defined as the difference between the lateral forces measured on the front steer axle. In most cases, a tire's pull value is of little concern when placed on the rear axle and does not affect the straight-ahead stability of the vehicle.

The measured loaded tire diameter (displayed for each tire/wheel assembly) can also affect the pull condition. A significant difference in these measurements may indicate under/over inflation in a tire or a mismatched set of tires.

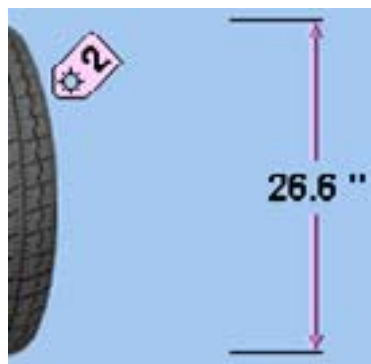

Another common factor that can affect steering pull or drift in relation to the tires is the variation in air pressure of the two tires when compared side to side on a given axle. Tire pressure measurement is prompted with a pop-up screen before every load roller measurement.

9. Glossary

9.1 Balancing Terms

Amplitude (Magnitude)

The amount of force or the intensity of the vibration.

Back Coning

When the wheel requires the cone to center the wheel on the balancer's shaft from the backside, primarily due to the chamfer of the wheel. Also referred to as Back-Cone Mounting.

Backspacing

The distance measured from the mounting face to the back edge of the wheel.

BDC

The abbreviation for bottom dead center also referred to as 6 o'clock.

Bead seating

The process of seating the tire to the rim bead seats. Bead seating preferably occurs just after the tire and rim have been assembled, but may gradually change and optimize over a longer period. If loaded with the GSP9700 load roller or driven, the position of the bead may optimize or always remain seated improperly, unless the tire is demounted, lubricated, and remounted. However, the load force and its' relatively short duration will not necessarily solve defective mounting of the tire bead seat to the rim seat.

Bolt Pattern Circle

The diameter of an imaginary circle drawn through the center of each lughole, and virtually always on the same centerline as the hub bore of the wheel.

Computerized Vibration Analyzer

A device used to determine the frequency of the vibration by isolating the vibrations with the greatest magnitude.

Cycle

One complete disturbance.

Dampen

To decrease the magnitude of a vibration or sound.

Dampers

Used to reduce the magnitude of a given vibration. Rubber is commonly used to isolate and dampen vibrations.

Dataset[®]

The inner and outer electronic arms on the GSP9700. By positioning the Dataset arms and entering data using the foot pedal, rim dimensions can be recorded for balancing.

Dynamic Balance

A procedure that balances the wheel assembly by applying correction weights in two planes so that up and down imbalance and wobble imbalance are eliminated.

Electro-Mechanical Ear

A device used much like a doctor's stethoscope and is for noise diagnosis problems only.

Force Matching™

A method of aligning the high spot of the tire's radial force variation with the low spot of rim runout to decrease rolling vibration in the wheel assembly.

Forced Vibration

Vibrates when energy is applied.

Free Vibration

Continues to vibrate after the outside energy stops.

Frequency

The number of disturbances that occur per unit of time.

Front Coning

When the wheel requires the cone to center the wheel on the balancer's shaft from the front. Also referred to as Front-Cone Mounting.

Harmonic

A vibration that is identified by the number of occurrences per revolution. For example, a 1st harmonic vibration has a once per revolution vibration component.

Hertz

A unit of frequency: one disturbance per second.

Hub Centric

The wheel is centered using the center hole of the wheel.

Inflation Station

A feature on newer models of the GSP9700 that automatically inflates or deflates tires to a predetermined air pressure.

Lateral Runout

The amount of side-to-side movement as the tire/wheel assembly rotates.

Lug Centric

The wheel is centered using the lugholes rather than the wheel center hole.

Magnitude (Amplitude)

The amount of force or the intensity of the vibration.

MatchMaker™

Allows the operator to match up four identical tires on identical rims, to achieve the optimal combination of match mounting.

Natural Frequency

The point at which an object will vibrate the easiest.

Order

The number of disturbances per cycle (rotation). For example, a 1st order vibration occurs once per cycle, and a 2nd order vibration occurs twice per cycle.

P, P/SUV, LT

“P Tires” refers to passenger tires, “LT Tires” refers to light truck tires, and “P/SUV Tires” refers to P-Rated sport utility vehicle tires.

Phase

The position of a vibration cycle relative to another vibration cycle in the same time reference.

Phasing

The cycle pattern of two or more vibrations that overlap and combine to increase the overall magnitude.

Pressure Ring

The accessory used to prevent the wing nut from contacting the wheel when on the balancer shaft.

Quick-Thread™

Motor assisted threading of the wing nut for quick installation and removal.

Radial Force Variation (RFV)

A term describing a measurement of the tire uniformity, under load, measuring the variation of the load acting toward the tire center.

Radial Runout

A condition where the tire and wheel assembly is slightly out of round forcing the spindle to move up and down as the vehicle rolls along a smooth surface.

Reed Tachometer

A mechanical device that uses reeds to indicate the frequency and magnitude of the vibration.

Resonance

The point where a vibrating component's frequency matches the natural frequency of another component.

Responding Component

The noticeable component that is vibrating.

Road Force™

A change in the force between the wheel and the axle while rotating under a load. Discrepancy in road force can cause a vibration although the tire and rim may be perfectly round and the tire is balanced.

Road Force™ Measurement

A measurement of the wheel assembly as would be found from an actual road test of a vehicle. The GSP9700 is equipped with a load roller to take the Road Force™ Measurement. The load roller places up to 1400 pounds of force on the spinning tire, and automatically measures the effects of loaded runout and tire stiffness to emulate tire/wheel assembly force variation.

Road Force™ Variation

A change in force exerted on the axle by the tire/wheel assembly while rotating under load. Units of measurement are in pounds, Newton's, etc.

Servo-Stop

The ability to locate varying positions of the tire/wheel assemblies and hold the position in place while correctional weights or OE-Matching marks are applied.

SmartWeight™ Balancing Technology

SmartWeight measures the forces placed on a wheel and balances in an effort to reduce those forces, thus saving weight, time, and money.

Source Component

A component causing another object to vibrate, such as a tire/wheel assembly.

Spindle-Lok®

A feature that locks the spindle in place by depressing the foot pedal.

Static Balance

A procedure that balances the wheel assembly using only a single weight plane.

TDC

An abbreviation for top dead center. Also referred to as 12 o'clock.

Torque Sensitive Vibration

The vibration occurs when accelerating, decelerating, or applying the throttle.

Total Indicated Reading (T.I.R.)

Data measurements taken by the load roller (measured in lbs. or kg) or Dataset® Arms (measured in inches or millimeters) representing the actual runout measured. The T.I.R. data represents the difference in value between the highest and lowest value measured.

Transference Path

The object(s) that transfer the frequency.

Vibration

A shaking or trembling, which may be heard or felt.

WeightSaver™ Feature

WeightSaver™ is the percentage of maximum shimmy allowed. The larger the percentage, the greater the weight savings.

Wheel Diameter

Dimension measured on the inside of the rim at the bead seats.

Wheel Offset

The measured distance between the mounting face of the wheel and the centerline of the rim.

Wheel Width

Dimension measured on the inside of the rim between the bead seats.